



EKX How to Demo

Live For Sound  
[www.electrovoice.com](http://www.electrovoice.com)



# EKX

## **SUPERIOR SOUND**

Precise coverage & superior sound quality at high SPLs

## **BEST CONTROL & MONITORING**

EV QuickSmartDSP

## **BEST DESIGN & QUALITY**

Versatile for all applications: portable & installed



[ **The EKX Series** ]

**EKX-12P**

**EKX-15SP**

**EKX-15P**

**EKX-18SP**

(Passive versions also available)

# Powered Speaker Demo





# Song Selection



\* Use only uncompressed Audio Format for Demo ( Wav/FLAC/ALAC )\*

**EKVX Tops**



## EKX-12P Full Range

- Soundtrack demonstrates dynamic abilities with soft guitar entry with wide range leading vocal
- Male voice sounding clear without low mid muddiness or mid frequency shrill (harshness)
- Demo Track:  
Thinking out loud – Ed Sheeran
- Alternative Track:  
Yesterday – Boys II Men



## EKX-12P DSP settings

- DSP setting:
  - Mode: Music,
  - Location :Tripod
  - Subwoofer: None
- Ensure no other settings such as EQ have been adjusted.



## EKX-15P Full Range

- Reproducing good “pop” and attack and decay from the snare
- Good definition of the bass guitar notes
- Electric guitar demonstrates good instrument separation at 0:34 onwards.
- Demo Track:  
Where the boat leave from – Zac Brown
- Alternative track:  
Billie Jean – Michael Jackson





## EKX-15P DSP settings

- DSP setting:
  - Mode: Music,
  - Location: Tripod
  - Subwoofer: None
- Ensure no other settings such as EQ have been adjusted.





# EKX Powered Tops with Subs

## EKX-12P with EKX-15SP

- Contemporary music recording that shows no harshness from the balanced system
- Tight bass and forwardness of vocals at the track opening
- Demo Track:  
Sledgehammer – Fifth Harmony
- Alternative Track:  
Fast Company – The Eagles



## EKX-12P with EKX-15SP - DSP settings

- DSP setting for EKX-12P:
  - Mode: Music,
  - Location: Tripod
  - Subwoofer: EKX-15SP
- DSP setting for EKX-15SP:
  - Mode: Music,
  - Location: Normal
  - Low Pass: EKX-12P



## EKX-15P with EKX-18SP

- Rock track emphasizes good coupling of 15 inch top and 18 inch sub with low distortion.
- Maintaining tight LF response from drums, instrument separation clearly maintained in this genre of music which is often difficult to reproduce
- “Closed in” vocals don’t get “muddied” amongst other instruments in the band
- Demo Track:  
Something for Nothing – Foo Fighters
- Alternative Track:  
Black Cat – Janet Jackson



## EKX-15P with EKX-18SP - DSP settings

- DSP setting for EKX-15P:
  - Mode: Music,
  - Location: Tripod
  - Subwoofer: EKX-18SP
- DSP setting for EKX-18SP:
  - Mode: Music,
  - Location: Normal
  - Low Pass: EKX-15P



## EKX-12P with 2 EKX-15SP

- Ultra low frequency bass without resonance at the beginning followed by clarity of finger snaps
- R&B genre demonstrating more impact with the addition of one more sub without being overly “bloated”
- Voice of the lead rapper demonstrates voice clarity with rich natural mids at the opening 0:25 without being voice getting thin
- Demo track:  
Trampoline – Kalin & Myles
- Alternative track:  
Pitbull – Ay Chico



## EKX-12P with 2 EKX-15SP - DSP settings

- DSP setting for EKX-12P:
  - Mode: Music,
  - Location: Tripod
  - Subwoofer: EKX-15SP
- DSP setting for EKX-15SP:
  - Mode: Music,
  - Location: Normal
  - Low Pass: EKX-12P





## EKX-15P with 2 EKX-18SP

- High energy track that demands headroom
- Most powerful combination
- Tight rounded Bass with great control and balanced output
- Clean sounding without aggression ( low distortion at extremes) , sound of digital synthesizers well separated in the track
- Demo track:  
Beg for it – Iggy Azalea
- Alternative Track:  
Ramstein - Ramstein



## EKX-15P with 2 EKX-18SP - DSP settings

- DSP setting for EKX-15P:
  - Mode: Music,
  - Location: Tripod
  - Subwoofer: EKX-18SP
- DSP setting for EKX-18SP:
  - Mode: Music,
  - Location: Normal
  - Low Pass: EKX-15P



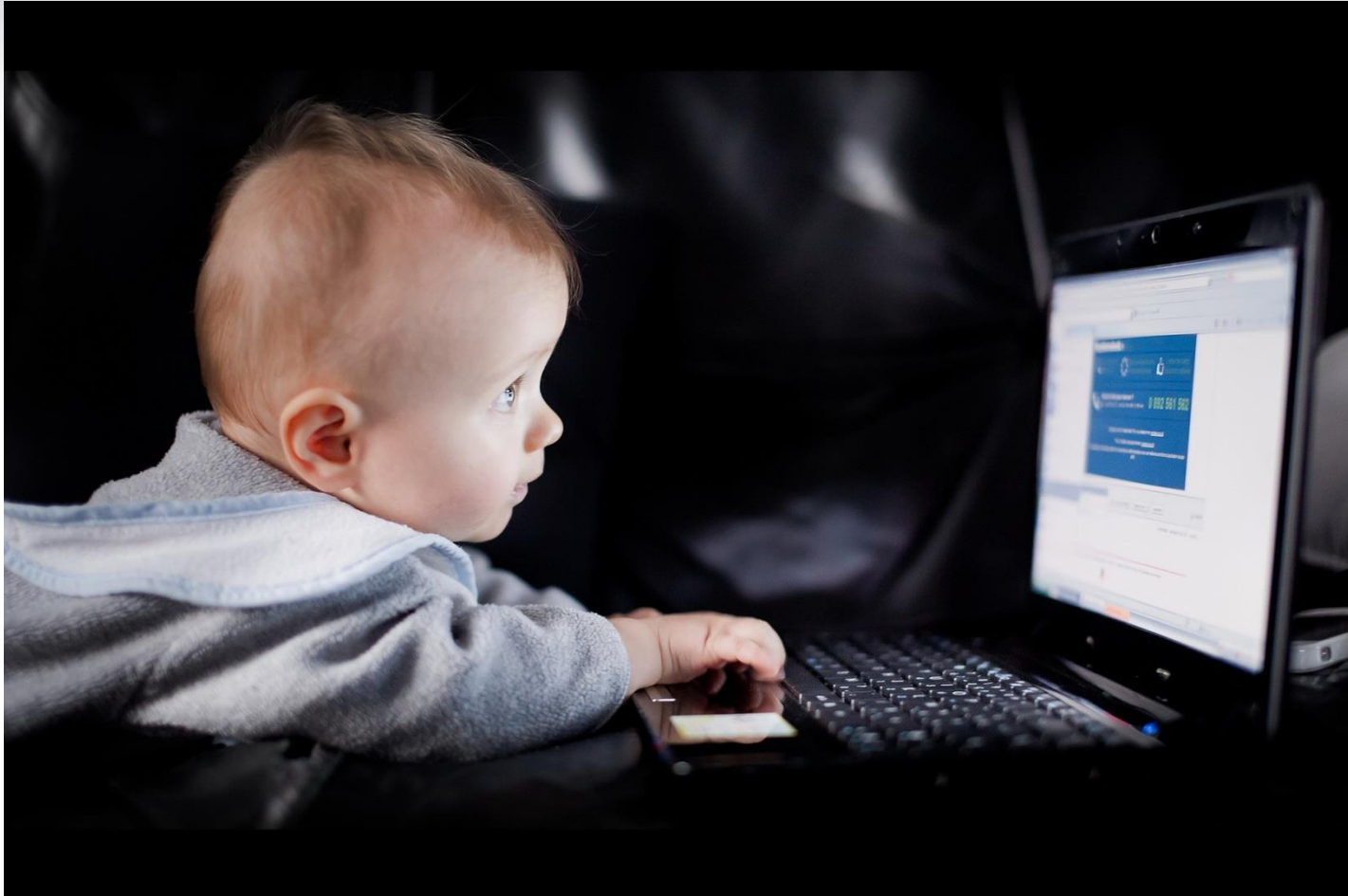

Recommended configuration

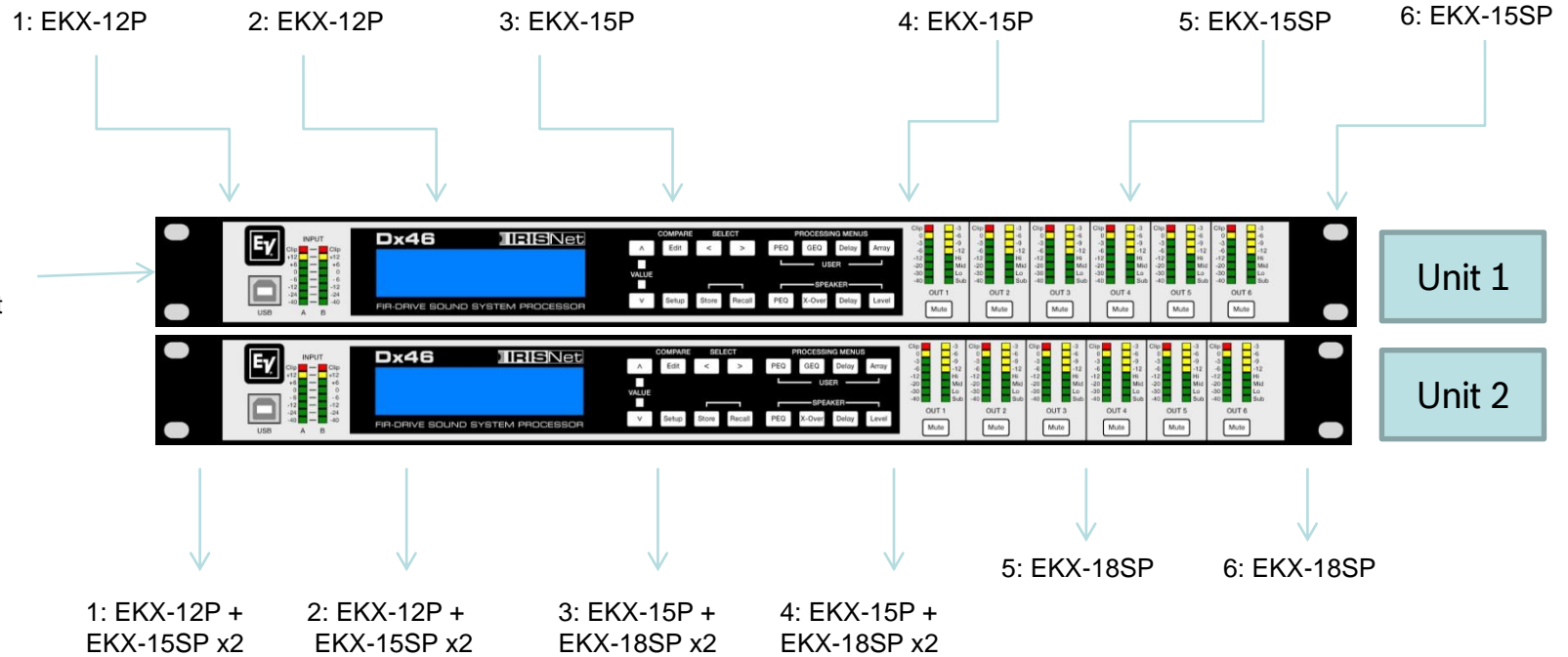

## Equipment list

For optimum demo equipment using DX 46 signalprocessors:

- 1) DX46 – 2 pcs. (AES/EBU preferred, due to wider dynamic range and lower noise floor )
- 2) 4 x EKX-12P
- 3) 4 x EKX-15P
- 4) 6 x EKX-15SP
- 5) 6 x EKX-18SP

This quantity allows single/dual subs demonstration where needed

## Speaker positions

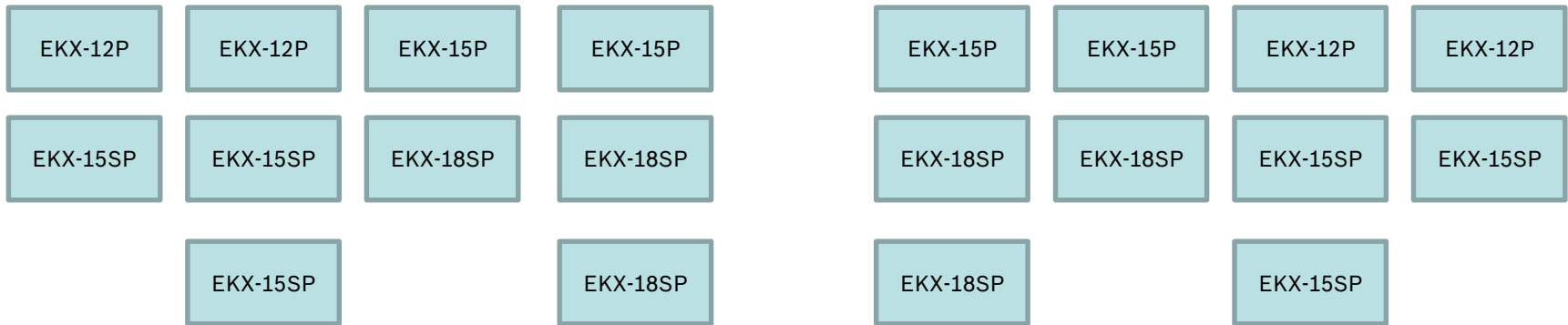

To audience

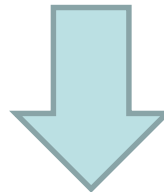

## Sequence Of Events

### Full Range

- Check modes on DSP
- ->EKX-12P DX46 1/2 PRESET 1
- ->EKX-15P DX46 1/2 PRESET 2
- Mute all subwoofers

### Tops + Subs

- ->EKX-12P + EKX-15SP DX46 1/2 PRESET 3
- ->EKX-15P + EKX-18SP DX46 1/2 PRESET 4
- ->EKX-12P + 2X EKX-15SP DX46 1/2 PRESET 5
- ->EKX-15P + 2X EKX-18SP DX46 1/2 PRESET 6

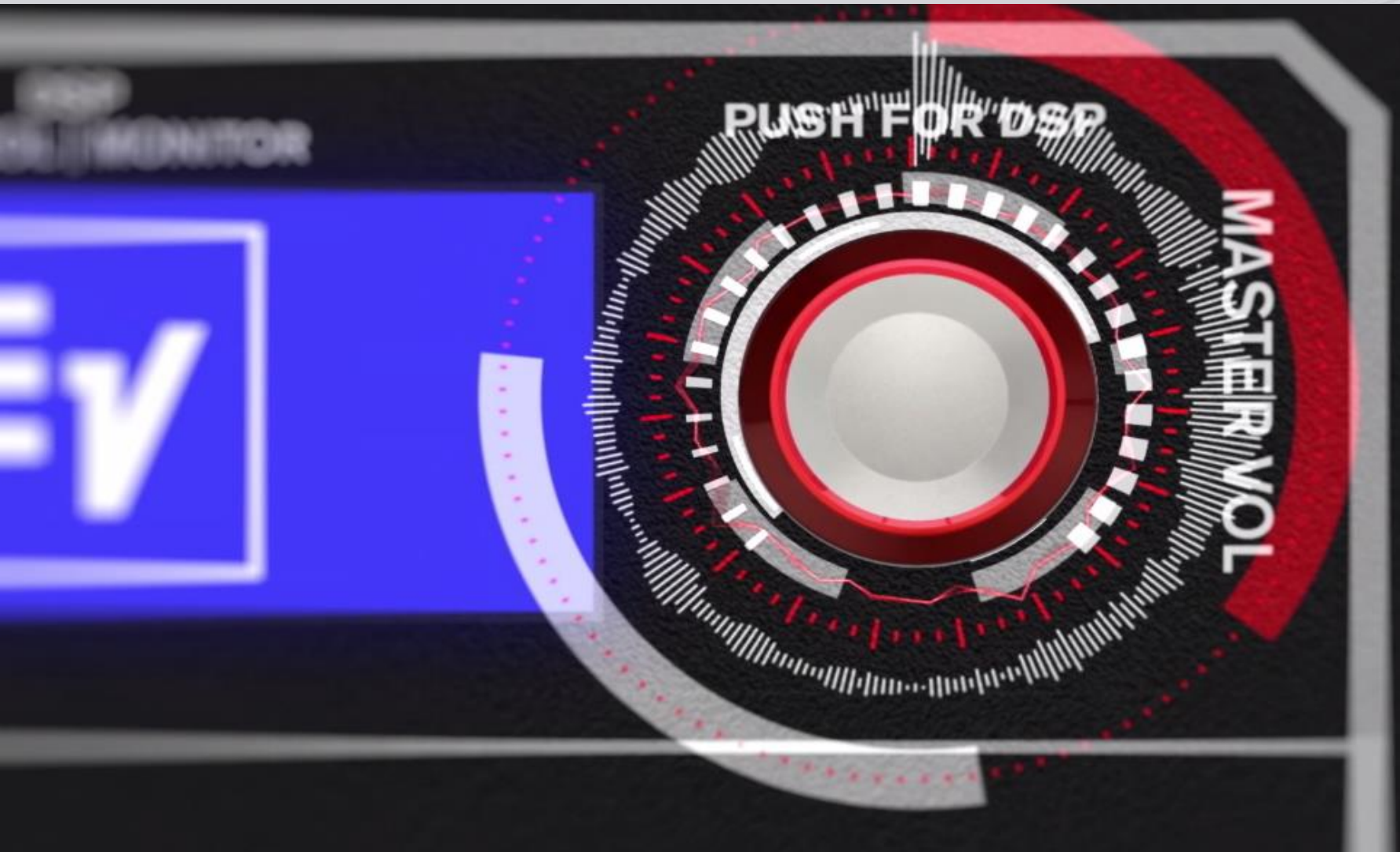

# Powered Speaker Checklist



# Demo check list for EKX top Full Range

## DSP setting

- Mode: Music, Location: Tripod, Sub: Off
- All gain trims knobs at “0dB”

## DX 46 Presets ( unit 1 + 2 )

- Preset 1 for EKX 12P Full range followed by Preset 2 for EKX 15P

## Demo track EKX-12P

- Thinking out loud – Ed Sheeran

## Demo track EKX-15P

- Where the boat leave from – Zac Brown

## End of full range demo

- Prepare to change DSP settings to be used with Subs



# Demo check list for EKX-12P with Subs

## DSP setting EKX-12P

- Mode: Music, Location: Tripod, Sub: EKX-15SP
- All gain trims knobs at “0dB”

## DSP setting EKX-15SP

- Mode: Music, Location: Normal, Low Pass: EKX-12P
- All gain trims knobs at “0dB”

## DX 46 Presets ( unit 1 + 2 )

- Preset 3 for EKX-12P + EKX-15SP
- Preset 5 for EKX-12P + 2x EKX-15SP

## Demo tracks

- Sledgehammer – Fifth Harmony 1x Sub
- Trampoline – Kalin & Myles 2 x Subs



# Demo check list for EKX-15P with Subs

## DSP setting EKX-15P

- Mode: Music, Location: Tripod, Sub: EKX-18SP
- All gain trims knobs at “0dB”

## DSP setting EKX-18SP

- Mode: Music, Location: Normal, Low Pass: EKX-15P
- All gain trims knobs at “0dB”

## DX 46 Presets ( unit 1 + 2 )

- Preset 4 for EKX-15P + EKX-18SP
- Preset 6 for EKX-15P + 2x EKX-18SP

## Demo tracks

- Something from nothing – Foo Fighters 1x Sub
- Beg for it – Iggy Azalea 2 x Subs



# EKX-12P + 2 x EKX-15SP example

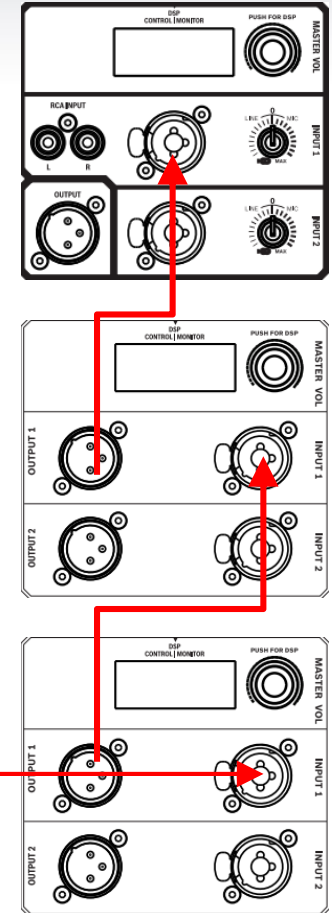
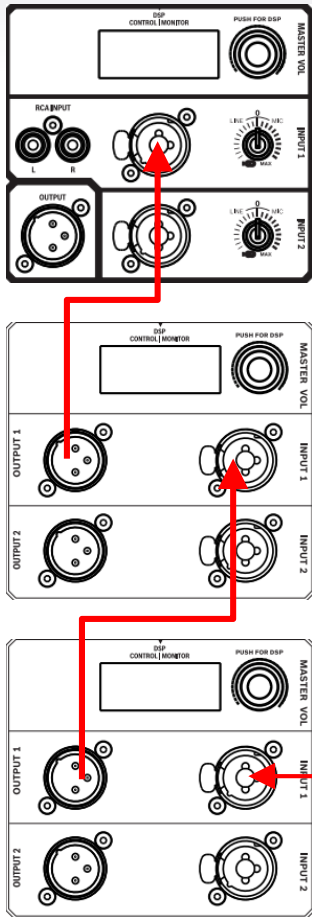

## DX46 (Unit 2)

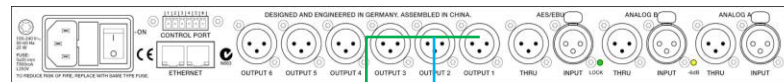

Left CH  
Output 1

Right CH  
Output 2



**EV** Electro-Voice

**CARDIOID CONTROL  
TECHNOLOGY**

**Cardioid Demo**



# Cardioid Subwoofer options

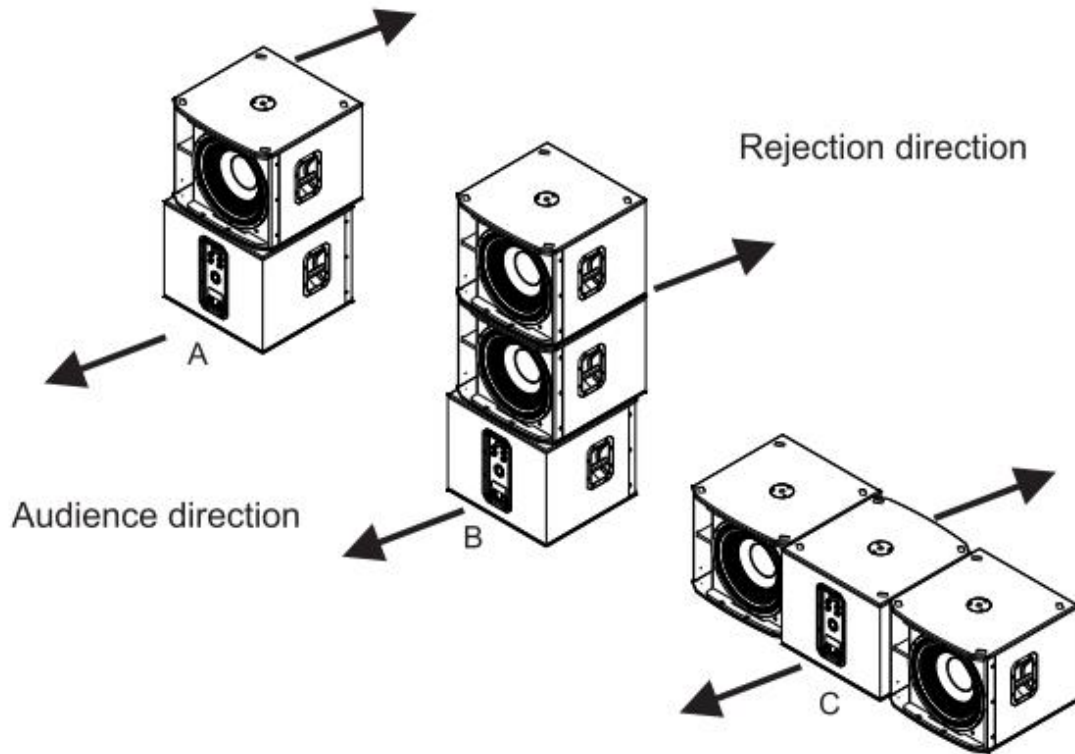

## Cardioid Demo for non believers

- Ensure subs are placed as illustrated for maximum cardioid effect
- Make sure all feet of top sub feet falls into feet cutout of bottom sub
- Use only one input source to EACH sub, set both subs to same level, '0dB', ensure top sub location "Normal" and bottom "Cardioid"
- Use pink noise source and move around the 2 subs to observe difference in bass output from one side to the other



DSP structure for cardioid subwoofer setup,  
cabinet facing the audience

Function

- Music

Location

- Normal

Low  
Pass

- EKX 15SP/EKX 18SP

EXIT

MODE: MUSIC

LOCATION: NORMAL



DSP structure for cardioid subwoofer setup,  
cabinet facing the stage

Function

- Music

Location

- Cardioid

Low  
Pass

- EKX 15SP/EKX 18SP



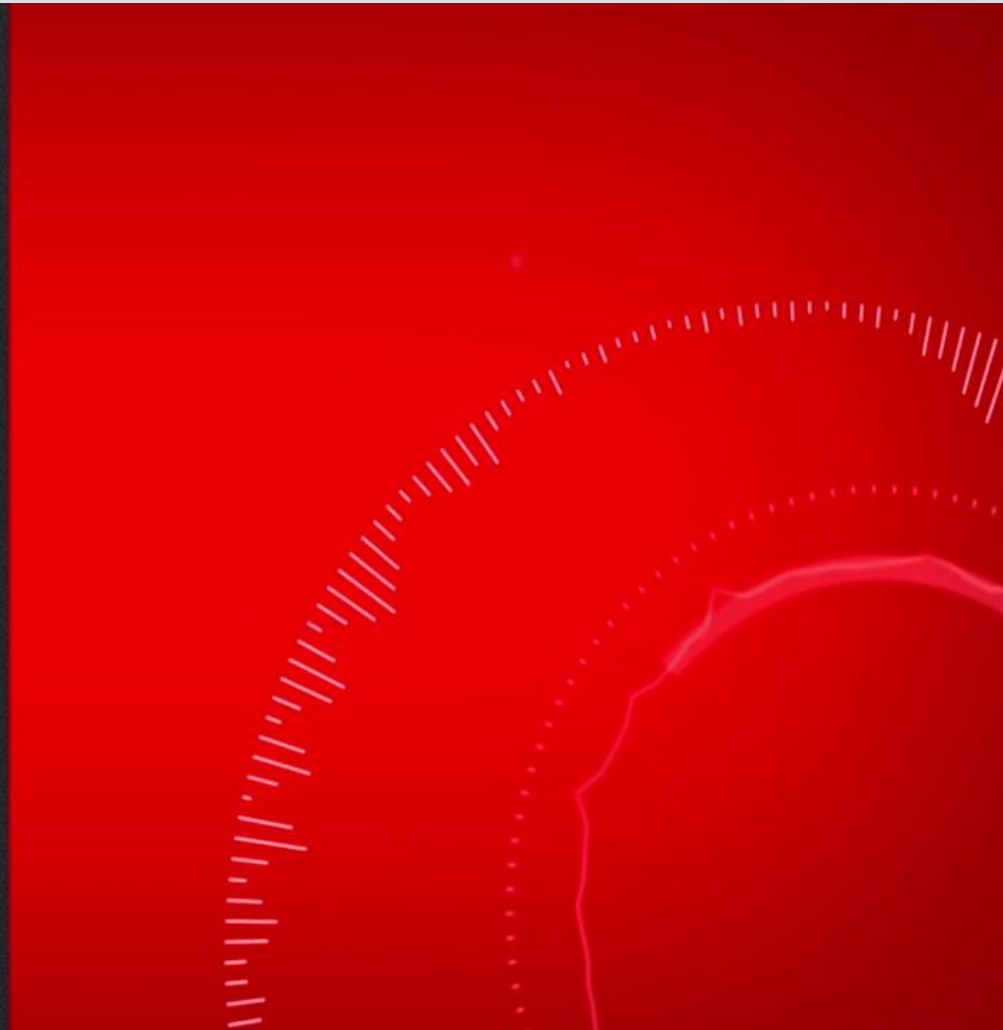

# DSP Final Checks

## DSP structure for EKX tops

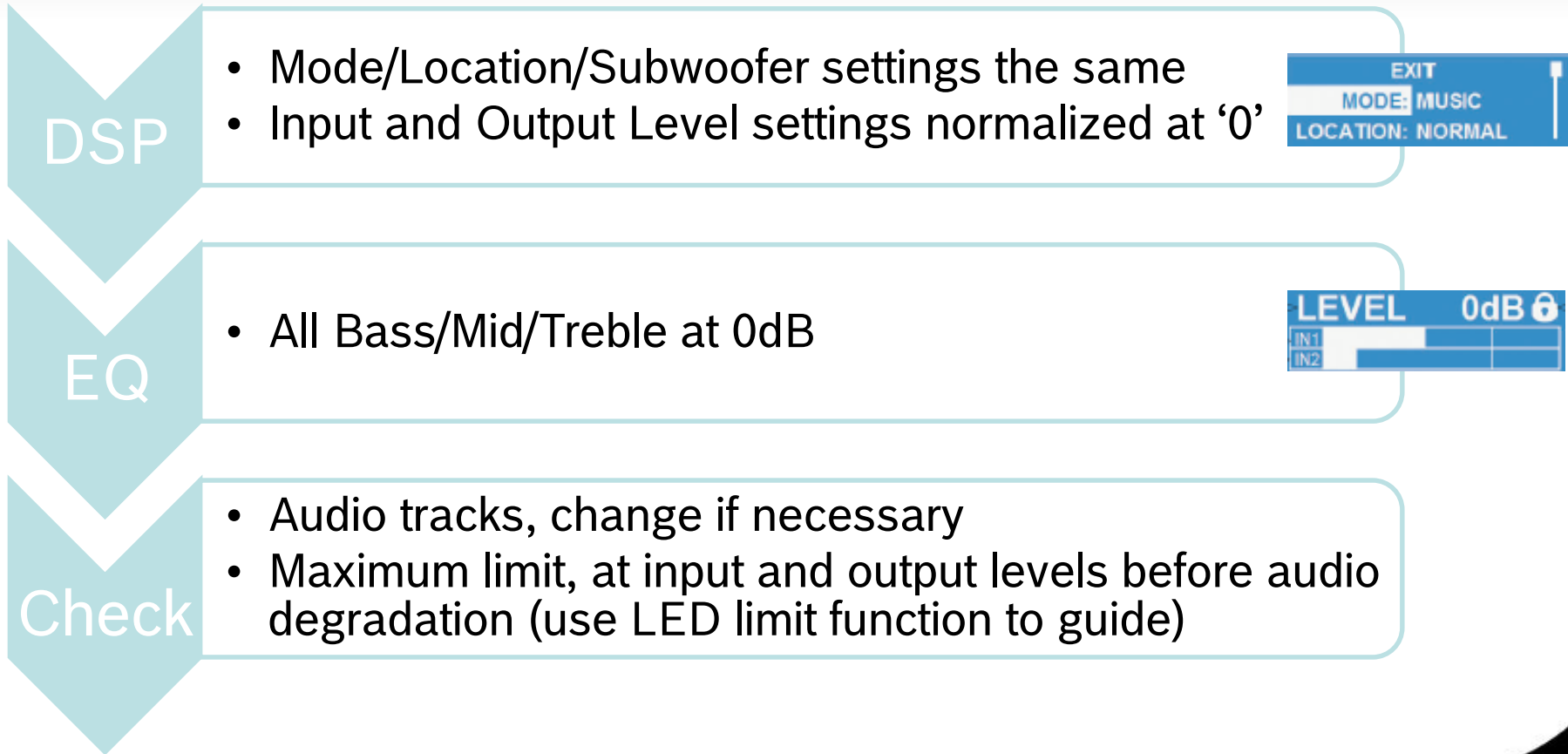

## DSP structure for EKX subs

DSP

- Mode/Location/Low Pass settings the same
- Output Level settings normalized at '0'

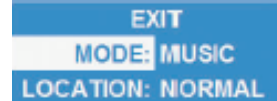

EXIT  
MODE: MUSIC  
LOCATION: NORMAL

Check

- Audio tracks, change if necessary
- Maximum limit, at input and output levels before audio degradation ( use LED limit function to guide )



# Passive Speaker Demo

1: EKX-12  
Amp 1 Ch A

2: EKX-12  
Amp 1 Ch B

3: EKX-15  
Amp 2 Ch A

4: EKX-15  
Amp 2 Ch B

5: EKX-15S  
Amp 3 Ch A

6: EKX-15S  
Amp 3 Ch B

Analog or  
AES/EBU input

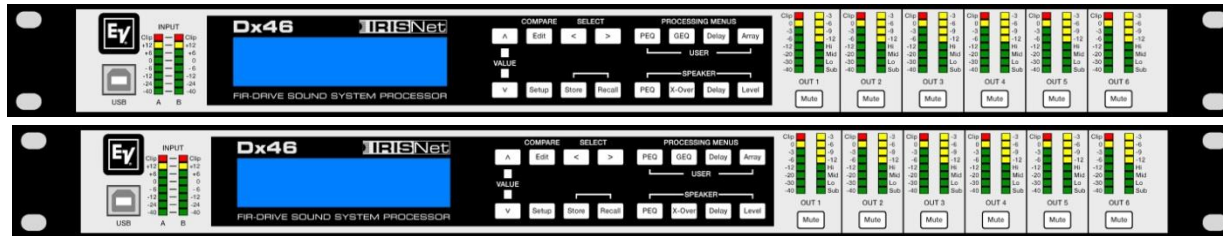

Unit 3

Unit 4

1: EKX-15S  
Amp 4 Ch A

2: EKX-15S  
Amp 4 Ch B

3: EKX-18S  
Amp 5 Ch A

4: EKX-18S  
Amp 5 Ch B

5: EKX-18S  
Amp 6 Ch A

6: EKX-18S  
Amp 6 Ch B

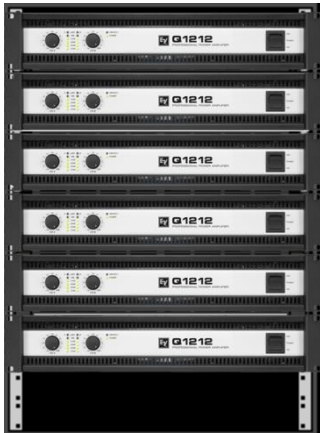

## Speaker positions

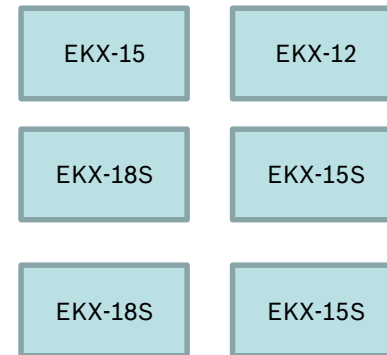
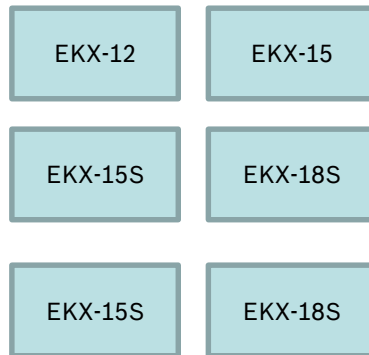

To audience



## Passive subs settings in IRIS-Net

- Enter values subwoofer crossover frequencies
- Use 80/90/100 Hz settings depending on preference
- Enter '0' for subwoofer gain and adjust higher or lower when needed
- Store the preset in DX46 ( unit 3+4) after changes





## Amplifiers needed for Demo

- For normal systems, recommended amps are:  
for all EKV tops, Q99/Q1212  
for all EKV subs Q1212 for more headroom,

Ensure for all Q series amplifiers: LPN is 'Off'.

- For ultimate audio performance during demo, each speaker shall be driven by TG-5 amplifiers without RCM modules, but ensure proper limiter settings and take care not to over drive the system.





# Passive Speaker Checklist

## Demo check list for EKX tops Full Range

### **DX 46 Presets ( unit 3 + 4 )**

→ Preset 7 for EKX-12 Full range followed by Preset 8 for EKX-15

### **Demo track EKX-12**

→ Thinking out loud – Ed Sheeran

### **Demo track EKX-15**

→ Where the boat leave from – Zac Brown



## Demo check list for EKX-12 with Subs

### **DX 46 Presets ( unit 3 + 4 )**

→ Preset 9 for EKX-12 + EKX-15S

→ Preset 11 for EKX-12 + 2x EKX-15S



### **Demo tracks**

→ Sledgehammer – Fifth Harmony 1x Sub

→ Trampoline – Kalin & Myles 2 x Subs



## Demo check list for EKX-15 with Subs

### **DX 46 Presets ( unit 3 + 4 )**

- Preset 10 for EKX-15 + EKX-18S
- Preset 12 for EKX-15 + 2x EKX-18S



### **Demo tracks**

- Something from nothing – Foo Fighters 1x Sub
- Beg for it – Iggy Azalea 2 x Subs



Thank you