



*S_x*A Series Powered Loudspeakers Owner's Manual



*S_x*A100+
*S_x*A250
*S_x*A180



IMPORTANT SAFETY INSTRUCTIONS



The lightning flash with arrowhead symbol, within an equilateral triangle is intended to alert the user to the presence of uninsulated "dangerous voltage" within the product's enclosure that may be of sufficient magnitude to constitute a risk of electric shock to persons.



The exclamation point within an equilateral triangle is intended to alert the user to the presence of important operating and maintenance (servicing) instructions in the literature accompanying the appliance.

1. Read these instructions.
2. Keep these instructions.
3. Heed all warnings.
4. Follow all instructions.
5. Do not use this apparatus near water.
6. Clean only with a damp cloth.
7. Do not block any of the ventilation openings.
Install in accordance with the manufactures instructions.
8. Do not install near any heat sources such as radiators, heat registers, stoves, or other apparatus that produce heat.
9. Only use attachments/accessories specified by the manufacturer.
10. Refer all servicing to qualified service personnel. Servicing is required when the apparatus has been damaged in any way, such as power-supply cord or plug is damaged, liquid has been spilled or objects have fallen into the apparatus, the apparatus has been exposed to rain or moisture, does not operate normally, or has been dropped.

For US and CANADA only:

Do not defeat the safety purpose of the grounding-type plug. A grounding type plug has two blades and a third grounding prong. The wide blade or the third prong are provided for your safety. When the provided plug does not fit into your outlet, consult an electrician for replacement of the obsolete outlet.

IMPORTANT SERVICE INSTRUCTIONS

CAUTION: These servicing instructions are for use by qualified personnel only. To reduce the risk of electric shock, do not perform any servicing other than that contained in the Operating Instructions unless you are qualified to do so. Refer all servicing to qualified service personnel.

1. Security regulations as stated in the EN 60065 (VDE 0860 / IEC 65) and the CSA E65 - 94 have to be obeyed when servicing the appliance.
2. Use of a mains separator transformer is mandatory during maintenance while the appliance is opened, needs to be operated and is connected to the mains
3. Switch off the power before retrofitting any extensions, changing the mains voltage or the output voltage.
4. The minimum distance between parts carrying mains voltage and any accessible metal piece (metal enclosure), respectively between the mains poles has to be **3 mm** and needs to be minded at all times.
The minimum distance between parts carrying mains voltage and any switches or breakers that are not connected to the mains (secondary parts) has to be **6 mm** and needs to be minded at all times.
5. Replacing special components that are marked in the circuit diagram using the security symbol (Note) is only permissible when using original parts.
6. Altering the circuitry without prior consent or advice is not legitimate.
7. Any work security regulations that are applicable at the location where the appliance is being serviced have to be strictly obeyed. This applies also to any regulations about the work place itself.
8. All instructions concerning the handling of **MOS** - circuits have to be observed.

Note:



SAFETY COMPONENT (HAS TO BE REPLACED WITH ORIGINAL PART ONLY)



Table of Contents

SxA Owner’s Manual	2
Safety First	3
Description	4
System Features – SxA Two-Way Systems.....	4
System Features - SxA 180 Powered Woofer	4
System Setup	5
Setup Diagrams for SxA Two-Way Systems	6
SxA180 Woofer System Setup	8
F22 Monitor Foot Accessory	11
System Specifications	12
Electro-Voice® Uniform Limited Warranty	13

SxA Owner’s Manual

Thank you for choosing Electro-Voice® SxA active powered loudspeaker systems.

These systems are the culmination of EV’s 75 years of experience in transducer design and over 50 years of experience in designing and building electronics.

Please take time to consult this manual so that you can understand all the features built into your EV systems and fully utilize all their performance capabilities.



Safety First

When setting up, installing and using Electro-Voice® SxA speaker systems, there are a number of precautions that you should follow:

- When Electro-Voice® SxA speakers are used for portable applications in which they will be stacked directly on the floor or mounted on a tripod stand, make sure that the floor or stage is solid and secure.
- Electro-Voice® SxA speaker systems include 1 3/8-inch stand mounts to allow mounting on tripod stands.

Make sure to:

- Check the specifications of the speaker stand to be certain it is capable of supporting the weight of the speaker.
- Check that the speaker stand is placed on a flat, stable surface and be sure to fully extend the legs of the stand. Do not try to make the stand “taller” and compromise its structural integrity.
- Route cables and position the stand so that performers, production crew and audience members will not trip over the stand or cables and pull the speaker system over. Secure cables with wire ties or tape whenever possible.
- Do not attempt to suspend more than one speaker on a stand designed for a single speaker.
- Unless you are confident that you can safely handle lifting the weight of the speaker onto the stand, ask another person to help you place it.
- After the system is in operation for a few minutes, the heat sink will become warm to the touch and can become quite hot after extended high-level operation. Avoid touching the heat sink fins to prevent burns. When installing the system, use care to ensure that there is at least two inches of space behind the heatsink to allow free circulation of air.
- If you intended to hang or fly the SxA two-way systems, please do so safely with the correct hardware and accessories.



WARNING: *Suspending any object is potentially dangerous and should only be attempted by individuals who have a thorough knowledge of the techniques and regulations of rigging objects overhead. Electro-Voice® strongly recommends that SxA speakers be suspended taking into account all current national, federal, state and local regulations. It is the responsibility of the installer to ensure that SxA speakers are safely installed in accordance with all such regulations. If SxA speakers are suspended, Electro-Voice® strongly recommends that the system be inspected at least once a year. If any sign of weakness or damage is detected, remedial action should be taken immediately. Please consult our manual entitled *Suspending System 200 Loudspeakers*, and the SK1 data sheet, which details the various hardware kits that are available to safely suspend SxA speakers and how each kit should be used. There are also data sheets for each EV hanging hardware part that should also be consulted prior to suspending speakers.*



- Electro-Voice® does not recommend use of SxA speakers outdoors or in high moisture environments. Avoid exposing SxA speakers to direct moisture and or high humidity that can cause corrosion of electrical contacts and problems with loudspeaker cones and surrounds.



- Electro-Voice® SxA loudspeakers are easily capable of generating sound pressure levels sufficient to cause permanent hearing damage to anyone within normal coverage distance. Caution should be taken to avoid prolonged exposure to sound pressure levels exceeding 90 dB.



Description

Electro-Voice® *SxA* series powered loudspeakers are fully integrated audio systems with carefully matched electronics and transducers. These products make it easy to setup a high-quality sound system quickly with a minimum of cables and external electronics. They retain typical EV ruggedness, reliability and impeccable sound quality.

System Features – *SxA* Two-Way Systems

- Integrated mixer/crossover/amplifiers/speaker system with separate mic and line inputs, EQ and line-level outputs.
- Two built-in power amplifiers, one for low frequencies and one for high frequencies. The amplifiers also contain electronic crossover circuitry and CD horn compensation optimized for the speaker components as well as a limiter circuit that prevents either amplifier from clipping while preserving the sonic quality.
- The low-frequency power amplifier delivers 150 watts continuous average power and 350 watts dynamic power (IHF A). Dynamic output power is important because it determines the transient capability of the system.
- The high-frequency power amplifier delivers 50 watts continuous average power and 80 watts dynamic power (IHF A). This provides more than 3 dB of headroom over the continuous current capabilities of the high-frequency driver.
- The line input utilizes Neutrik “combo” connectors, which will accept either ¼-inch or 3-pin XLR-type connectors.
- The mic input is balanced, low-impedance 3-pin XLR-type
- The separate line output is 3-pin XLR-type balanced, low-impedance output that can be used with long cable runs.
- Two-band EQ provides tonal shaping to compensate for program material, room acoustics and personal taste.
- *SxA* two-way systems are perfect for use as powered floor monitors.

System Features - *SxA* 180 Powered Woofer

- Integrated power amplifier, electronic crossover and low-frequency speaker designed to add extended bass to *SxA* systems
- Class D amplifier with 300 watts continuous average power, 650 watts dynamic power (IHF-A). A built-in limiter prevents serious amplifier clipping and minimizes the potential for speaker damage.
- 18-inch EV DL woofer with 2.5-inch voice coil for reliable low-frequency output to 38 Hz.
- Line input with balanced 3-pin XLR-type connector
- Crossover with continuously variable low-pass frequency from 80 Hz to 120 Hz
- Filtered high-pass output and paralleled full-range output on balanced 3-pin XLR-type connectors.
- Storage compartment with detachable dolly board and casters for easy transportation. The dolly board covers a storage compartment that holds a 34-inch pole and has ample space for cables, etc.
- Comes with 34-inch pole for elevating any EV speaker system with 1 3/8-inch stand mount.



System Setup

To get your SxA system into operation as quickly as possible, please observe the following steps and precautions (see Figures 3-7)

- Plug the 3-terminal IEC 16-gauge ac cable into a grounded line receptacle. Extension cords can be used to lengthen the ac cable as necessary but make sure that they are 3-conductor 14 gauge or greater, and that are properly grounded to avoid electrical hazards and extraneous noise.
- Be sure that the SxA system is plugged into an ac power source that is capable of supplying the correct voltage. If the line voltage drops too much, the built-in amplifiers won't be able to develop their rated power and sound quality will suffer. Under high signal conditions, the SxA amplifier section can pull 2 – 4 amps of current (120 volt models) (1 – 2 amps at 240 volts). That means that no more than 4-SxA systems should be plugged into a single 15 amp electrical service. Be cautious of what else is plugged into the same electrical service line to avoid electrical problems and poor performance.
- BEFORE TURNING THE POWER ON, MAKE SURE THAT THE LEVEL CONTROLS ARE DOWN TO AVOID TRANSIENTS OR UNEXPECTED LOUD SOUND. Turn on the power switch and ensure that the system is receiving power by monitoring the status LED to the left of the switch above the EQ controls. If the system is receiving power, the LED will illuminate green.
- SxA loudspeakers have narrower coverage than other compact loudspeaker systems. Their narrower coverage will help you avoid room acoustics problems by delivering the sound where the speaker is aimed. You will find that precisely aiming the speakers at the audience area away from walls will give you better sound quality.

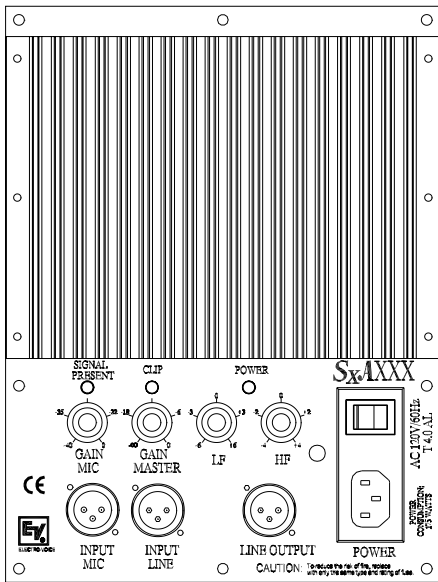

Figure 1:

Rear Panel SxA100+ and SxA250

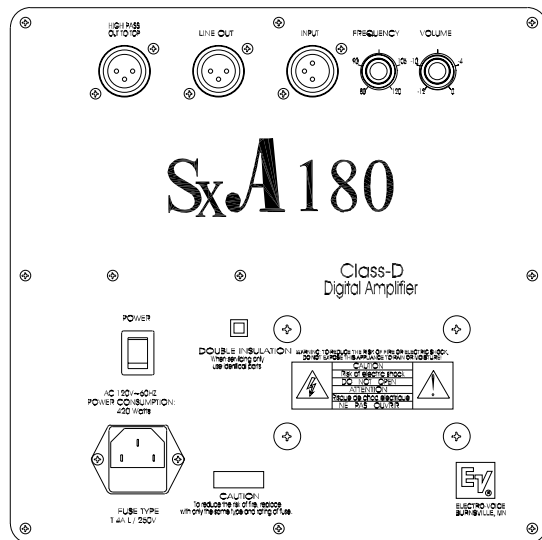

Figure 2:

Rear Panel SxA180

Setup Diagrams for S_xA Two-Way Systems

To use the S_xA two-way system for various applications:

- Plug a microphone into the microphone input connector (See Figure 3). It will only accept low-impedance dynamic microphones terminated with a standard 3-pin XLR-type connector. Turn the gain control clockwise until the signal present LED stays on with the input signal at normal operational level. Adjust the master gain control to the desired overall output level.
- Plug a line input into either the ¼-inch or the 3-pin XLR-type input connector. Examples of line input sources are mixer outputs, CD/DVD players, cassette decks, VCRs, electronic keyboards, computer sound cards, etc. The ¼-inch input is in the center of the XLR connector and can accept unbalanced or balanced lines (TRS ¼-inch). The line input level required to drive the unit to full power is from – 12 dBu to 0 dBu. The system's master gain control regulates the overall output level of the system.

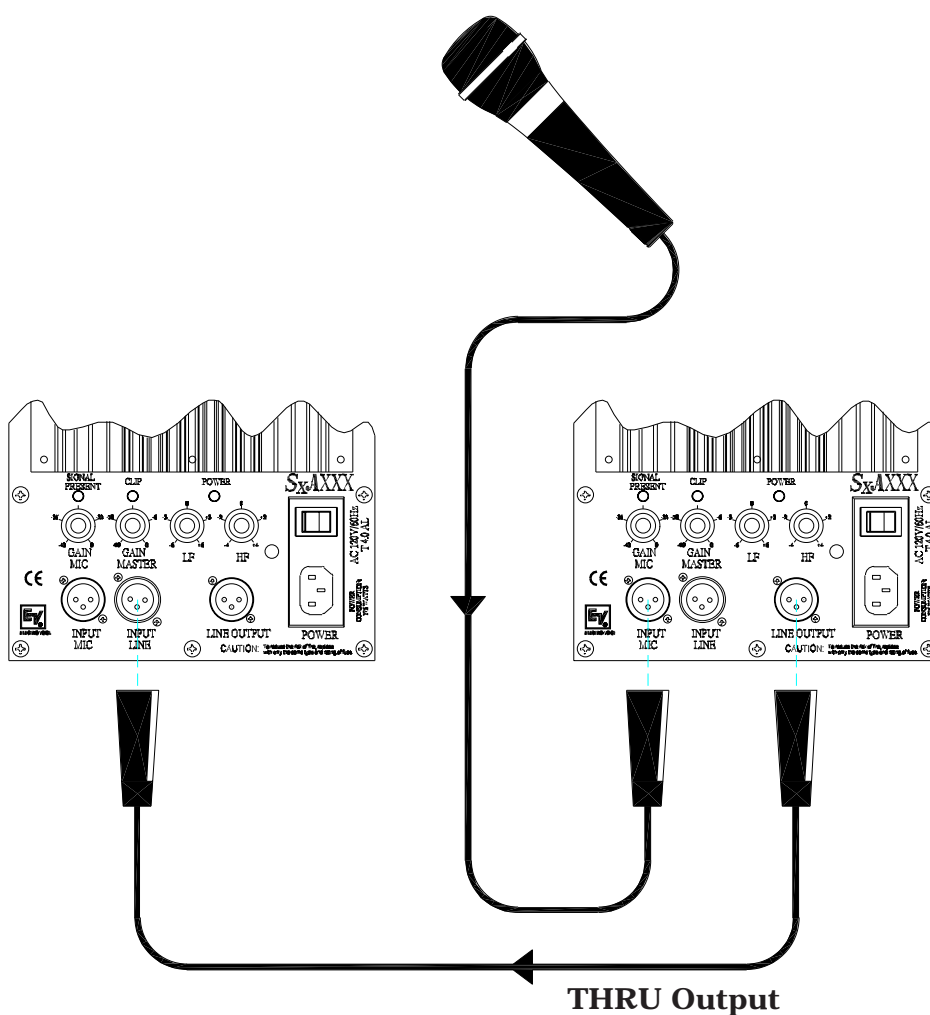

Figure 3:
Microphone Input Connections
& Connections To Additional Systems



Setup Diagrams for SxA Two-Way Systems (cont.)

- If you are using the SxA two-way system with a microphone and a line input simultaneously, it is simple to balance the two signals. The microphone level control has enough gain and range so that it is possible to mix the mic input and the line input. Once the balance between the line and mic inputs is set, simply turn the Gain Master control to the desired level.
- If there is no sound, keep the overall system gain at a reduced level until you determine what the problem may be. Typically, a mixer mute switch may be engaged or a microphone that is switched off is the source of the problem. Keeping the system gain at a low level will allow you to troubleshoot the problem and let you hear the results without unexpected bursts of sound or howling feedback. Start with the low-frequency and high-frequency EQ controls set in the flat position (12 o'clock, middle position) and listen to your program material before making any changes. Be aware that boosting EQ requires additional amplifier power and may reduce the acoustic output potential of the system somewhat. Use EQ judiciously.
- To route the signal to additional SxA systems, simply hook an XLR-type cable from the line output connector on the source system to the line input connector on each additional SxA system. The signal can be cascaded into a large number of SxA systems without degradation.
- When turning your system off, turn off the SxA systems first. This will prevent any turn-off transients from other pieces of equipment from being amplified.

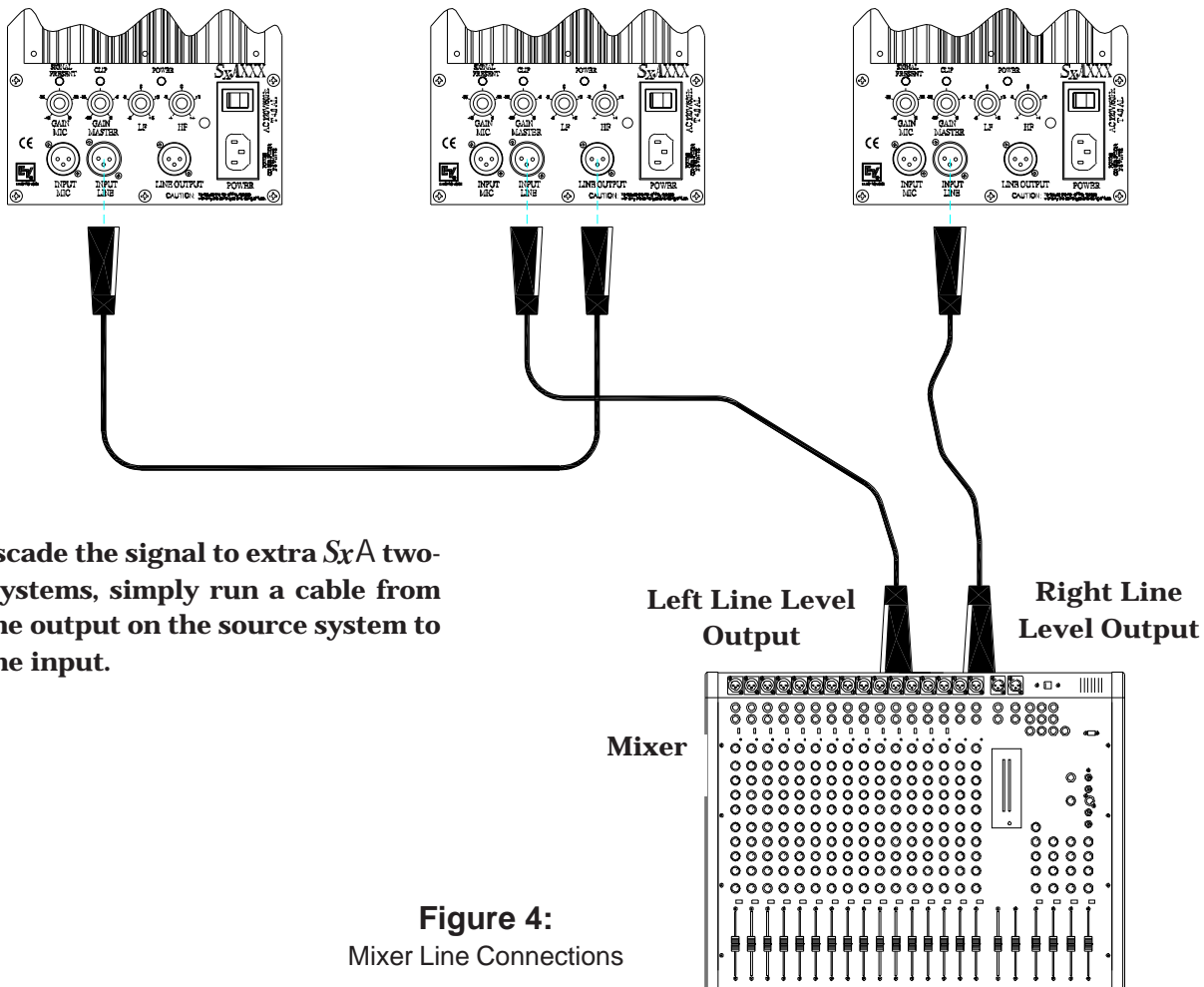

Figure 4:
Mixer Line Connections

SxA180 Woofer System Setup

To get your woofer system into operation as quickly as possible, please observe the following steps and precautions:

- Plug the 3-terminal IEC 16-gauge ac cable into a grounded line receptacle. Extension cords can be used as necessary but make sure that they are the 3-conductor type that are 14 gauge or greater, and are properly grounded to avoid electrical hazards and extraneous noise.
- Turn on the power switch and ensure that the system is receiving power by monitoring the status LED power on. **MAKE SURE THAT THE LEVEL CONTROLS ARE TURNED DOWN TO AVOID TRANSIENTS OR UNEXPECTED LOUD SOUND.**
- Attach a 3-pin XLR cable to the line-level input from a line-level output on your mixer.
- If you are using the SxA180 with an SxA two-way system, you will want to use the high-pass output to run the signal from the SxA180 to the two-way (See Figure 5). Using the filtered output will insure that the SxA180 only is reproducing low bass information which will let the two-way system sound cleaner and play louder. The unfiltered output is the best way to parallel the signal to other SxA180s or if you want more mid-bass output from the speaker setup.

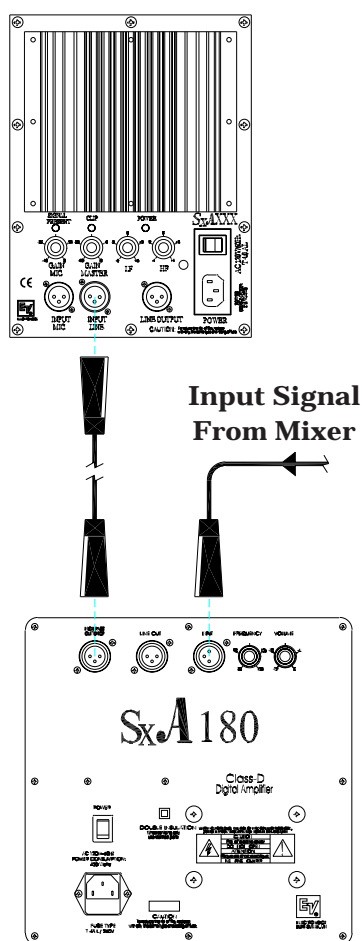

Figure 5:
Panel Close-up



SxA180 Woofer System Setup (cont.)

- After you have confirmed that the signal is present, adjust the level control and the crossover frequency. The selection of a crossover frequency will depend on room acoustics and your particular sonic taste. In general, a lower crossover frequency will result in a more linear, “hi-fi” sound and a higher crossover frequency will give your sound more “thump.”

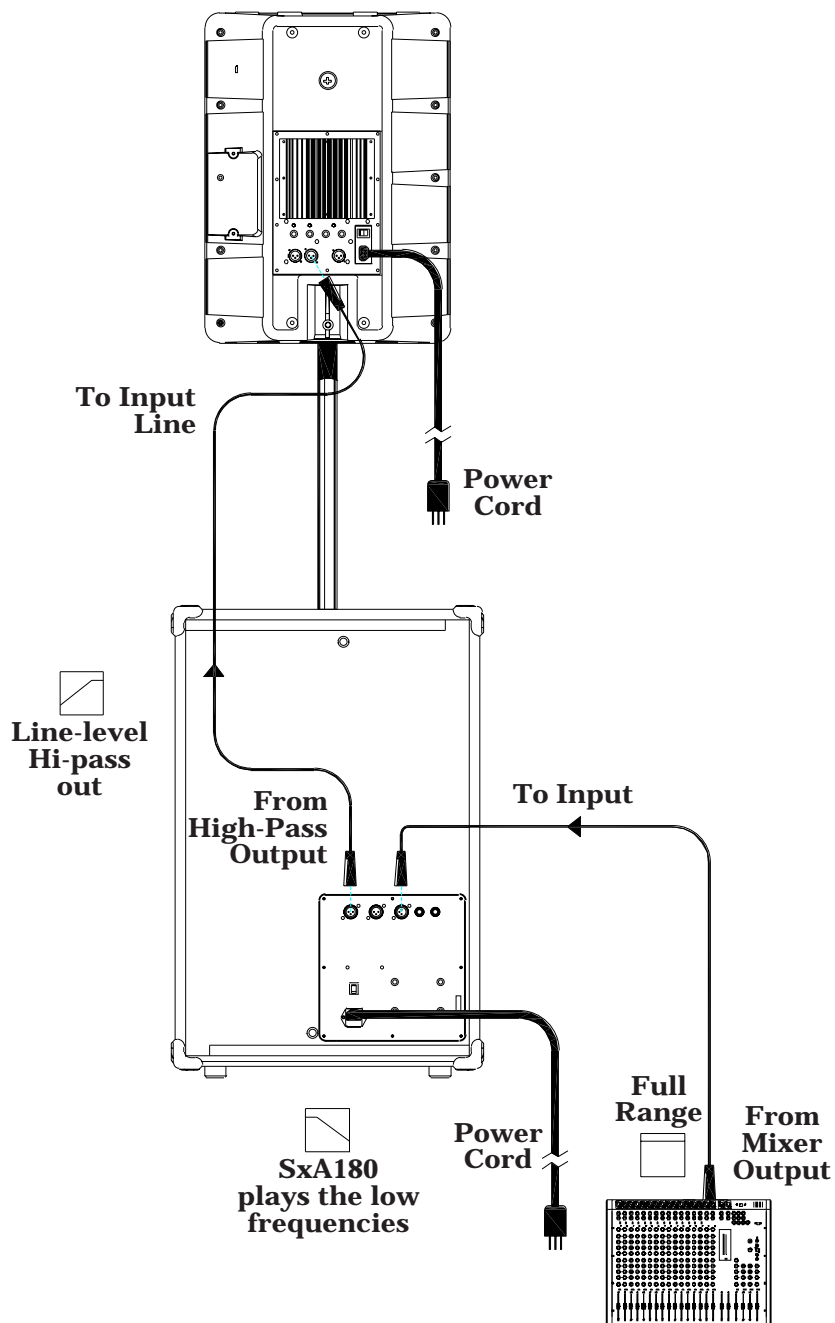

Figure 6:
Rear View



SxA180 Woofer System Setup (cont.)

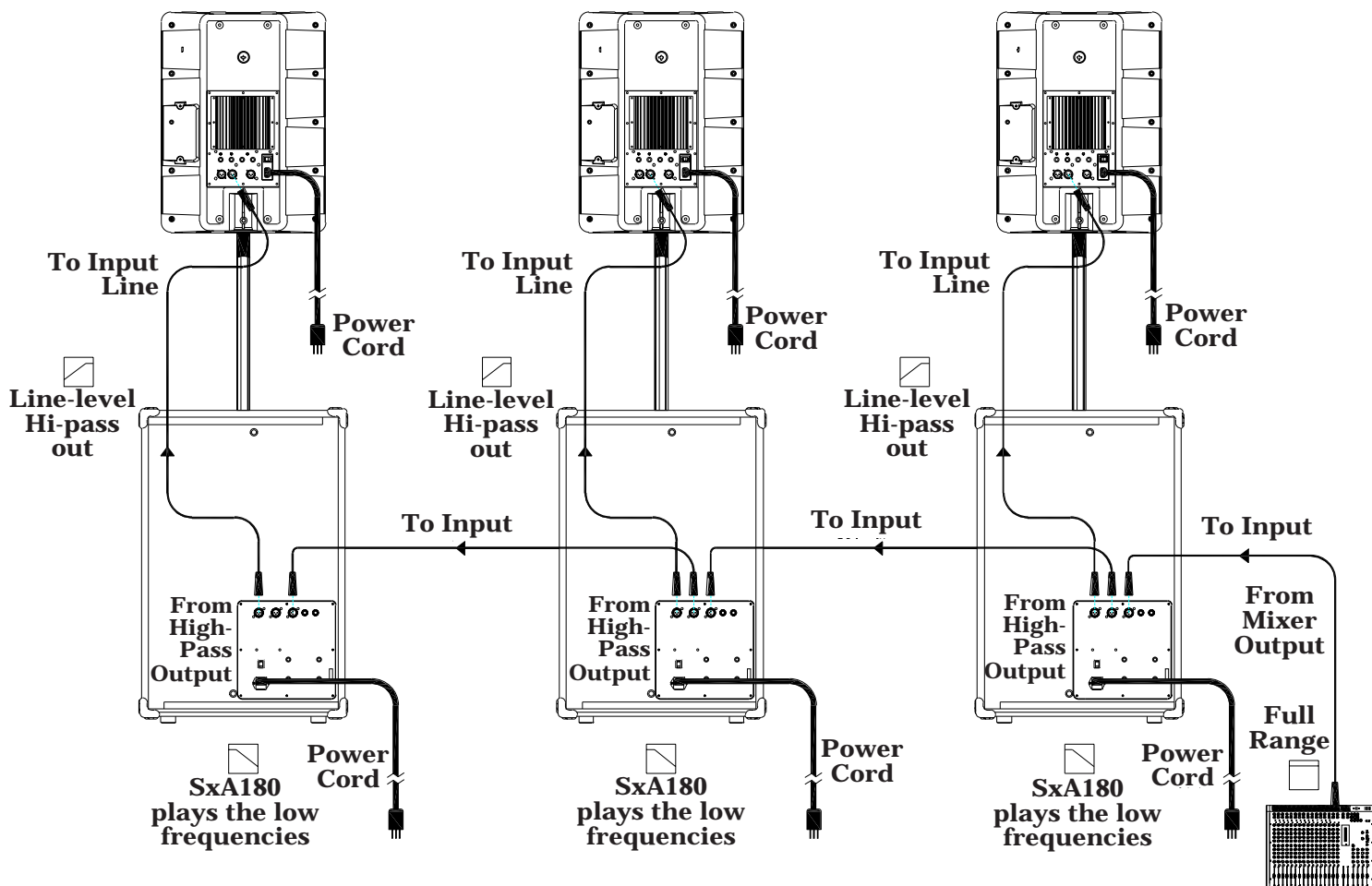

Figure 7:
Cascade Signal in Multiple Box Hook Up



Using Two-Way SxA Systems as Floor Monitors

SxA two-way systems are perfect for use as powered floor monitors.

The correct projection angle is already incorporated into the enclosure design of the SxA250. Simply turn the SxA250 on its side and operate the system in the same manner as described above. The F200 adapters are necessary to convert the SxA100 into a monitor and are shipped with the speaker. To install the adapters, simply insert them into the speaker (See Figure 8 below). The F200 adapters can be easily removed by pulling in the opposite direction.

The F200 Monitor Foot kit contains two plastic feet.

The F200 is used with any 12-inch Sx or SxA speaker enclosures.

Insert the feet firmly into the holes in the rear cabinet (See Figure 8).

Remove the F200 monitor feet by pulling in the opposite direction.

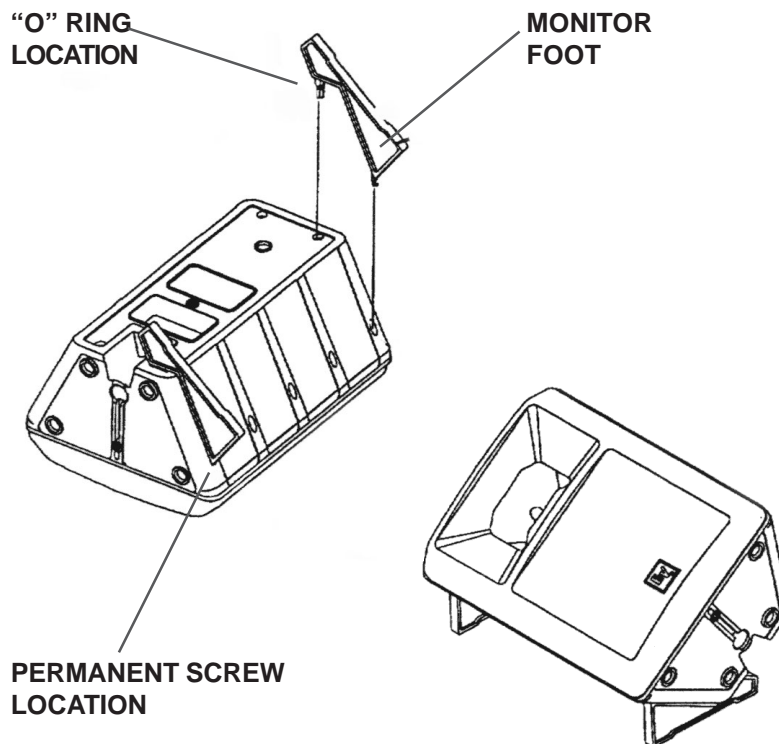

FIGURE 8:

Installing the F200 Monitor Foot on SxA100+ Speaker

CAUTION: The F200 monitor feet protrude from the enclosure. Care should be taken when moving the enclosure, since damage to the feet or enclosure might occur if the system is dropped or slid across a rough surface. It is recommended that the feet be removed for transport.



System Specifications



SxA100+



SxA250

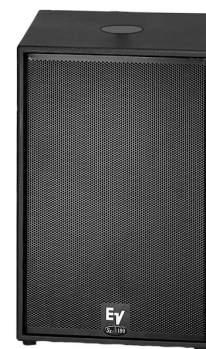

SxA180

Frequency Response	65 - 20 kHz	50 - 20 kHz	38 - 120 hz
Maximum calculated SPL @ 1M	124 dB	126 dB	126 dB
Coverage, -6 dB	65° x 65°	80° x 55°	omnidirectional
LF amplifier power, IHF-A	350 watts	350 watts	650 watts
LF amplifier power, continuous	150 watts	150 watts	300 watts
HF amplifier power, IHF-A	80 watts	80 watts	n/a
HF amplifier power, continuous	50 watts	50 watts	n/a
Mic input sensitivity range	-35 dBu to 0 dBu	-35 dBu to 0 dBu	n/a
Line input sensitivity range	-12 dBu to 0 dBu	-12 dBu to 0 dBu	-12 dBu to 0 dBu
Input connections	XLR mic, 1/4" or XLR line	XLR mic, 1/4" or XLR line	XLR line
Line output connections	XLR	XLR	XLR line, XLR high-pass
Equalization - LF	+6 dB @ 140 Hz shelving	+ 6 dB @ 140 Hz shelving	80 - 120 Hz crossover
Equalization - HF	+ 4 dB @ 5 kHz shelving	+ 4 dB @ 5 kHz shelving	n/a
Power requirement - 120 V	110 - 130 VAC, 50 -60 Hz	110 - 130 VAC, 50 -60 Hz	110 - 130 VAC, 50 -60 Hz
Power requirement - 240 V	220 - 240 VAC, 50 - 60 Hz	220 - 240 VAC, 50 - 60 Hz	220 - 240 VAC, 50 - 60 Hz
Power Consumption	600 watts	600 watts	700 watts
Enclosure material	polypropylene structural foam	18 mm plywood	18 mm plywood
Dimensions (H x W x D) in	23.1 x 16.9 x 12.3 in	24.6 x 17.2 x 13.1 in	31.5 x 21 x 23.5 in
Dimensions (H x W x D) mm	586 x 429 x 312 mm	640 x 406 x 471 mm	800 x 533 x 596 mm
Net weight	43 lb / 19.5 kg	49 lb / 22.2 kg	98 lb / 44.5 kg



ELECTRO-VOICE® UNIFORM LIMITED WARRANTY

Electro-Voice® products are guaranteed against malfunction due to defects in materials or workmanship for a specified period, as noted in the individual product-line statement(s) below, or in the individual product data sheet or owner's manual, beginning with the date of original purchase. If such malfunction occurs during the specified period, the product will be repaired or replaced (at our option) without charge. The product will be returned to the customer prepaid. **Exclusions and Limitations:** The Limited Warranty does not apply to: (a) exterior finish or appearance; (b) certain specifics described in the individual product-line statement(s) below, or in the individual product data sheet or owner's manual; (c) malfunction resulting from use or operation of the product other than as specified in the product data sheet or owner's manual; (d) malfunction resulting from misuse or abuse of the product; or (e) malfunction occurring at any time after repairs have been made to the product by anyone other than Electro-Voice or any of its authorized service representatives. **Obtaining Warranty Service:** To obtain warranty service, the customer must deliver the product, prepaid, to Electro-Voice or any of its authorized service representatives together with proof of purchase of the product in the form of a bill of sale or receipted invoice. A list of authorized service representatives is available from Electro-Voice® at 600 Cecil Street, Buchanan, MI 49107 (616/695-6831 or 800/234-6831). **Incidental and Consequential Damages Excluded:** Product repair or replacement and return to the customer are the only remedies provided to the customer. Electro-Voice® shall not be liable for any incidental or consequential damages including, without limitation, injury to persons or property or loss of use. Some states do not allow the exclusion or limitation of incidental or consequential damages so the above limitation or exclusion may not apply to you. **Other Rights:** This warranty gives you specific legal rights and you may also have other rights, which vary from state to state.

Electro-Voice® Speakers and Speaker Systems are guaranteed against malfunction due to defects in materials or workmanship for a period of five (5) years from the date of original purchase. The Limited Warranty does not apply to burned voice coils or malfunctions such as cone and/or coil damage resulting from improperly designed enclosures. Additional details are included in the Uniform Limited Warranty statement.

Service and repair addresses for this product:

Telex Communications, 1 Telex Drive, Morrilton, Arkansas 56013 (501-354-0111)

World Headquarters:

Electro-Voice®, 12000 Portland Avenue South, Burnsville, Minnesota 55337 (952-884-4051)



U.S.A. and Canada:

For customer orders, contact the Customer Service department at:

800/392-3497 Fax: 800/955-6831

For warranty repair or service information, contact the Service Repair Department at:

800/685-2606

For technical assistance, contact Technical Support at:

866/78 AUDIO

Specifications subject to change without notice.

All Locations:

952-884-4051 Fax: 952-884-0043

www.electrovoice.com • Telex Communications, Inc. • www.telex.com

Printed in U.S.A

© Telex Communications, Inc. 1/2003

Part Number 38110-088 Rev B