



General Description:

DCS 400 Series modules increase the ProAnnounce system's control capabilities in many ways. The DCS system can be expanded at any time after installation for increased functionality. The DCS control system consists of the following components:

- DCS 400 main module chassis
- DCS 401R primary system control module.
- DCS 405R extension module.
- DCS 408R relay module.
- DCS 409R relay module.
- DCS 412R logic input module.
- DCS 416R analog I/O module.
- DCS 420 monitor unit.

The ProAnnounce operating system defines the total amount of supported control inputs and outputs. A ProAnnounce installation allows integrating a maximum of up to 8 DCS 401R control modules. A single control module can host up to 12 relay boards of the types DCS 408R / DCS 409R in any sequence. In addition, it is possible to connect up to 5 logic input modules, 2 analog I/O modules, and 2 rotary encoders. In total, the ProAnnounce system can manage up to following amounts of different DCS cards:

- 8 DCS 401R control modules.
- 48 DCS 408 / DCS 409 relay modules.
- 10 DCS 412 logic input module.
- 8 DCS 416 Analog I/O module
- 1 DCS420 Monitor Unit

DCS 400 19" RACK FRAME

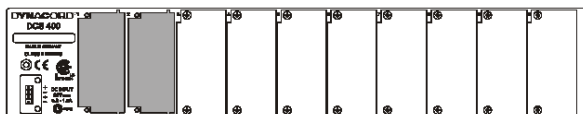

The DCS 400 is a 19" base unit with a height of 2 HU. It can host a control module as well as several relay modules, logic input modules, and analog I/O modules that are connected via internal backplane.

- 10 slots for the insertion of DCS modules.

- 4 position Phoenix type connector for power supply.
- 2 LED's on the front indicating power.
- Internal backplane with system bus.
- Internal self-resetting fuses.

DCS 401R CONTROL MODULE

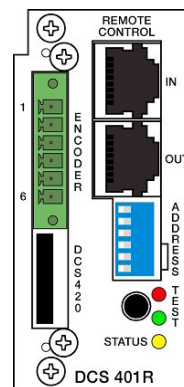

The module represents the interface for relay boards, logic boards, analog level I/O-boards, a monitor module, and rotary encoders. It is inserted into slot 1 (the slot all the way on the left) on the rear of the DCS 400 rack frame. It is controlled from the DPM 4000 via RS-485 remote interface. Maximally 12 relay modules (DCS 408R / DCS 409R / DCS 408 / DCS 409), 5 logic input modules (DCS 412R, DCS 412), 2 analog I/O modules (DCS 416R / DCS 416), 2 rotary encoders and 1

monitor module DCS 420 can be connected to a single DCS 401R control module.

- Two RJ-45 sockets for connecting the DPM 4000 and cascading several DCS 401R or DCS 401 modules.
- Galvanic isolated RS-485 port.
- Connector for 2 rotary encoders.
- Connector for DCS 420 monitor module.
- Monitoring via watchdog circuitry.
- Service-functions and testing-software for all connected modules.
- 6 binary switches for setting addresses and selecting service-functions
- 1 pen-tip pushbutton – test start.
- 3 LED's - red, yellow, green for test mode and status.
- A maximum amount of 8 modules DCS 401R or DCS 401 can be cascaded.

Specifications:

Operating voltage 24 V DC, -10 / +30%
 Operating current 25 mA to 65 mA
 Operating current at 24 V 35 mA
 Operating temperature range +5° C to +40° C
 Dimensions (W x H x D) 37.5 x 80.6 x 245 mm
 Weight 207 g

DCS 405R EXTENSION MODULE

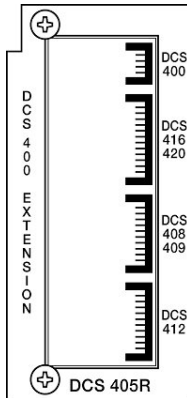

The module is used to provide connection to another DCS 400 rack frame and /or other DCS 400 boards. This is useful in situations where there are more cards on a given DCS 401R than a single DCS 400 frame can support.

Installation Notes

In the first DCS 400 rack frame the DCS 405R extension module always needs to be installed in the first empty slot (the slot right of any other modules installed). In the

DCS 400 extension unit – the second unit installed – the DCS 405R extension module always needs to be installed in slot 1 (the slot all the way on the left, instead of the DCS 401R).

Specifications:

Operating temperature range +5° C to +40° C
Dimensions (W x H x D) 37.5 x 80.6 x 245 mm
Weight 115 g

DCS 406R SHIELDING MODULE

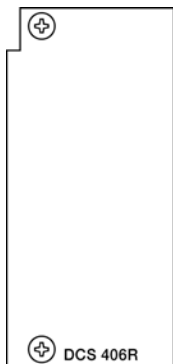

The module is meant for insertion on the rear of the DCS 400 rack frame providing shielding between DCS 408R and DCS 409R modules.

Specifications:

Dimensions (W x H x D) 37.5 x 80.6 x 245 mm
Weight 71 g

DCS 407R CONTROL RELAY MODULE

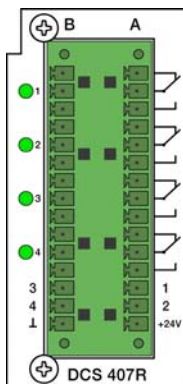

The module provides switching for audio signals (line level) or control outputs independent from the DCS 400 system.

- 4 LF-relays, each with 2 SPDT switching contacts.
- Gold-plated double-contacts for improved contact.
- Phoenix type connector for all contacts and coils.
- 4 relay control-LED's.
- Configuring the audio distributor is possible through separating wire-

bridges.

- Switchable monitor bus link.

Specifications:

Operating voltage 24V DC, -10% / +30%
Operating current, all relays on 37 to 54 mA
Operating current, all relays on at 24 V 42 mA
Operating temperature range +5° C to +40° C
Dimensions (W x H x D) 37.5 x 80.6 x 245 mm
Weight 163 g

Relay Contacts:

Contacts DPDT
Contact material AgPd + 10μ Au
Contact load (real) 1A / 24V DC, 0.5A / 120V AC
Contact current max. 2A

DCS 408R / 409R CONTROL RELAY MODULES

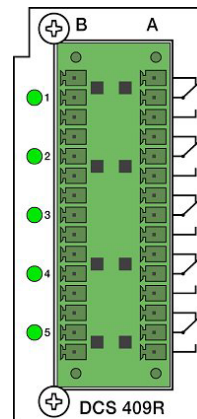

These modules provide relay contact closures for use in switching audio or other control functions. The 408R is capable of switching of 70v or 100V speaker lines. The 409R is capable of switching line level audio signals or control outputs. The 408R can also be used to provide contact closures where higher voltages and/or current may be involved.

- 5 line relays, each with 2 switching contacts.
- Phoenix type connector for all contacts.
- 5 relay control-LED's.
- Configuring the signal distributor is possible through separating wire-bridges.
- 12 DCS relay modules can be cascaded.

Specifications:

Operating voltage 24V DC, -10% / +30%
Operating current, relays off 5.2 mA to 7.8 mA
Operating current, relays off at 24 V 5.5 mA
Operating current, all relays on 55-130 mA
Operating current, all relays on at 24 V 60-96 mA
Operating temperature range +5° C to +40° C
Dimensions (W x H x D) 37.5 x 80.6 x 245 mm
Weight 225 g

Relay Contacts:

Contacts DPDT
Contact material AgNi 90/10
Contact load (real) 408R-2000 VA, 409R-1A

DCS 412R LOGIC INPUT MODULE

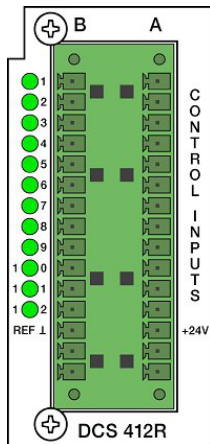

The module provides inputs for control lines, pushbuttons, switches, and sensors, allowing the evaluation of their individual status (ON / OFF) in the DPM 4000 system.

- 12 inputs.
- Selectable polarity of each input.
- Floating inputs can be realized via the separation of wire bridges.
- Separate connections for power supplies of pushbuttons, contacts and sensors.

- Phoenix type connector for all inputs.
- Maximally 5 DCS412R / DCS412 modules can be cascaded.

Specifications:

Operating voltage 24V DC, -10 / +30%
 Operating current, all inputs open 2.6 mA to 8.2 mA
 Operating current, all inputs at 24V 60 mA to 83 mA
 Operating temperature range +5° C to +40°C
 Dimensions (W x H x D) 37.5 x 80.6 x 245 mm
 Weight 175 g

Input Level:

Input voltage for off (Low) $U_{IN} < \pm 5$ V
 Input voltage for on (High) $U_{IN} > \pm 10$ V
 Input current at $U_{IN} = 24$ V $I_{IN} = 4.8$ mA
 Input voltage max. $U_{IN\ max} = \pm 31$ V
 Output source voltage 24V DC
 Output source current max. 90 mA

DCS 416R ANALOG I/O MODULE

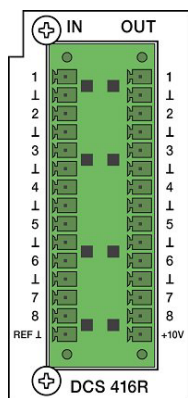

The module provides analog input and output interfacing capabilities for use in monitoring and control functions. Both inputs and outputs are capable of handling 0 to 10V DC with 256 distinct levels. Potentiometers for volume control can be interfaced using the provided reference voltage output.

- 8 analog inputs.
 - Voltages of 0 to 10V DC or a potentiometer to each input.
 - Output for reference voltage 10V DC.
- 8 analog outputs 0 to 10V DC.
 - Phoenix type connector for all inputs and outputs.
 - Maximally 2 DCS 416R / DCS 416 modules can be cascaded.

Specifications:

Operating voltage 24V DC, -10 / +30%
 Operating current (max.) 160 mA
 Operating temperature range +5° C to +40°C
 Dimensions (W x H x D) 37.5 x 80.6 x 245 mm
 Weight 170 g

Inputs:

Voltage range (min. to max.) 0 V to 10 V DC
 Impedance range ext. (min. to max.) 0 to 10 kOhm
 Maximum input voltage 50 V DC

Outputs:

Voltage range (min. to max.) 0 V to 10 V DC
 Output impedance 47 Ohm
 Maximum load 2k Ohm
 Resolution of Inputs / Outputs 8 Bit
 Reference output voltage 10 V DC
 Reference output current 30 mA (max.)

DCS 420 MONITOR STATION



The DCS 420 Monitor Manager is a 2RU unit offering acoustic control and visual level metering of audio in the system. Switching and displaying of up to 250 audio signal sources, as well as, controlling the volume is carried out via front panel control switches.

THE DCS420 receives its audio feed from the monitor output of the DPM4000. DCS420 system control functions are carried out through a connection to the DCS401 controller module. The front panel controls of the DCS420 offer audio level and line control switching of either the input signal or the output signal of the system amplifiers.

With several external sound sources connected, switching is performed through the DCS 409R module. When using remote-amplifiers, switching audio signals to the monitor bus is accomplished directly inside the amplifier. The signals are transmitted via remote interconnection cables

Architecture & Engineering Specifications:

The expansion system is designed for use with the ProAnnounce system and shall enable the use of a variety of system control and output routing devices. The system shall consist of a 2RU system rack frame accommodating any one of a series of 6 expansion control modules, which slide in the rear of the unit. The rack frame shall hold up to 10 expansion cards. It shall be powered from a 24V DC source supply through a dual spade lug terminal connection. The system shall be equipped with internal self-resetting fuses. The system shall enable the use of analog or digital controls; expand the system operation to include relay operated switching and remote monitoring. The system shall also offer the ability to add a rack mounted monitor unit for in place control and monitoring of any channel.

The expansion system shall be the Dynacord ProAnnounce DCS digital control system.

Available Accessories:

Model	Cat. No.	Description
NRS90240	121742	Volume Shaft Encoder

Ordering Information:

Model	Cat. No.	Description
DCS420	121753	Monitoring Unit
DCS400	121773	19" Frame for DCS Modules
DCS401R	121774	Controller Module
DCS405R	121775	Extension Module
DCS406R	121776	Shield Module
DCS407R	121777	AF-Relay Module w/Ext Control
DCS408R	121778	Lines-Relay Module
DCS409R	121779	AF-Relay Module
DCS412R	121780	Logic Input Module
DCS416R	121782	Analog I/O Module

Block Diagrams:

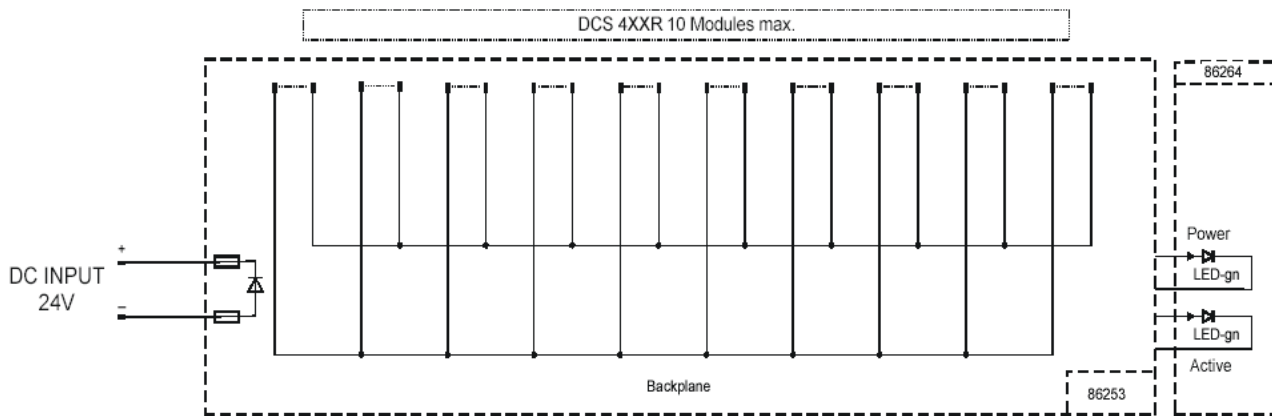

Rack Frame
DCS 400
 BLOCK DIAGRAM

Block Diagrams:

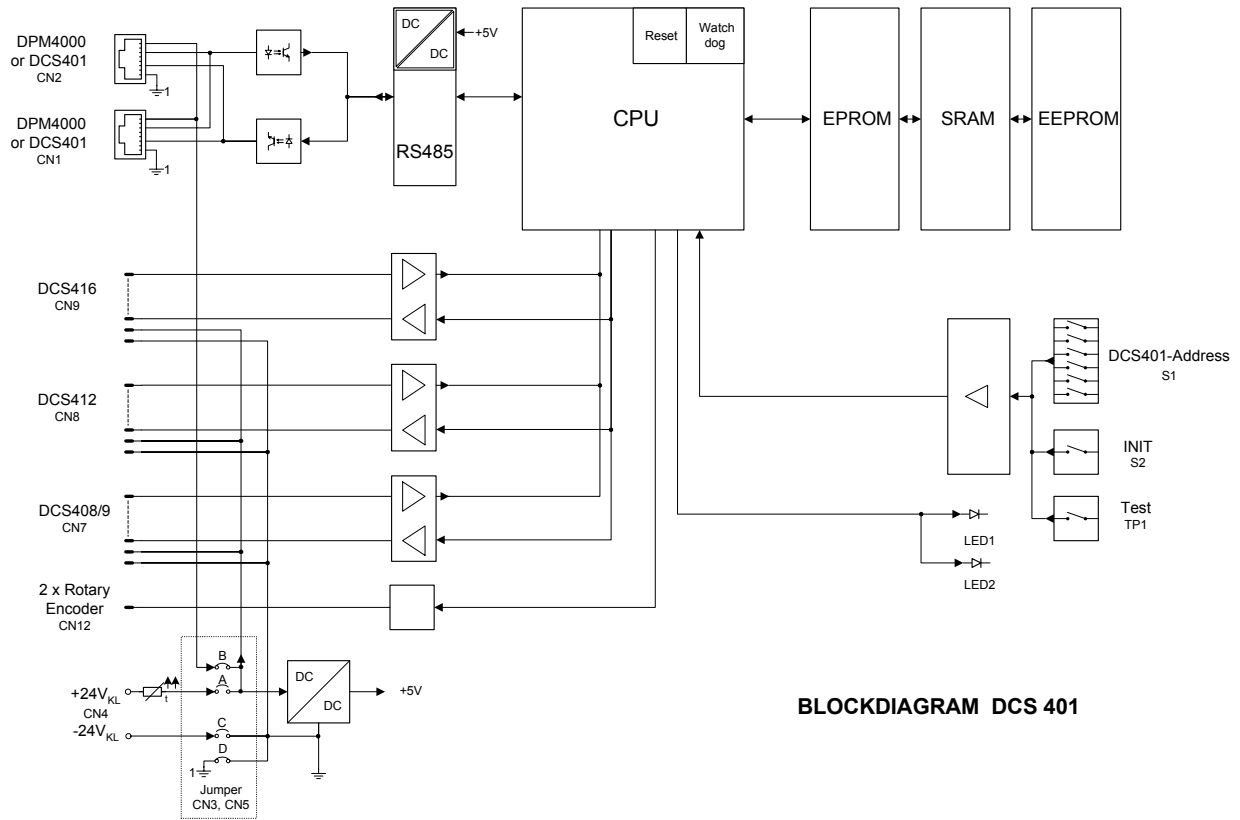

BLOCKDIAGRAM DCS 401

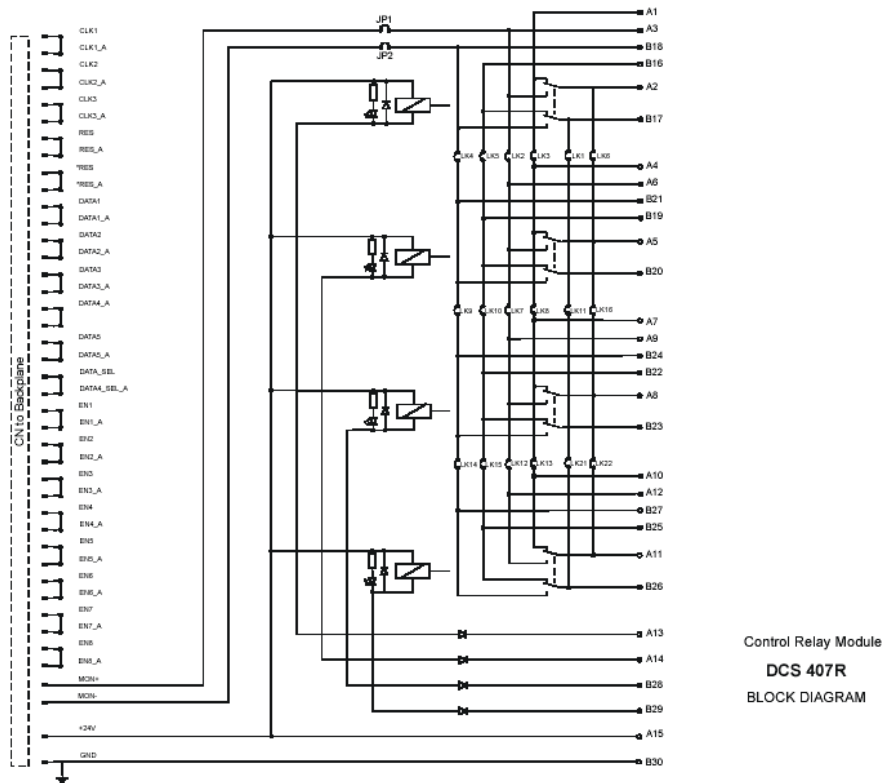

**Control Relay Module
DCS 407R
BLOCK DIAGRAM**

Block Diagrams:

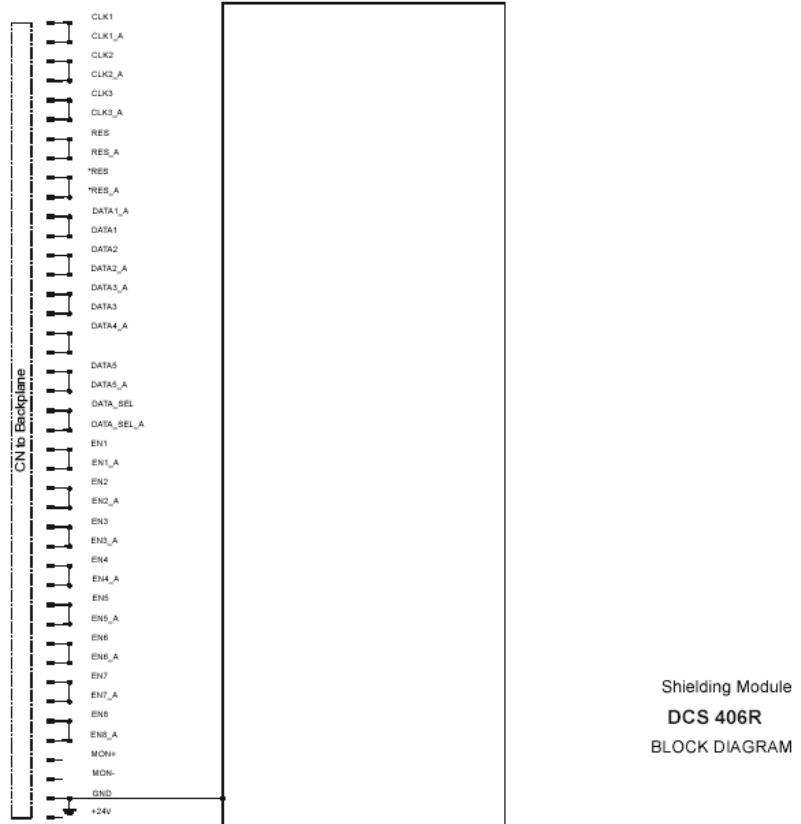
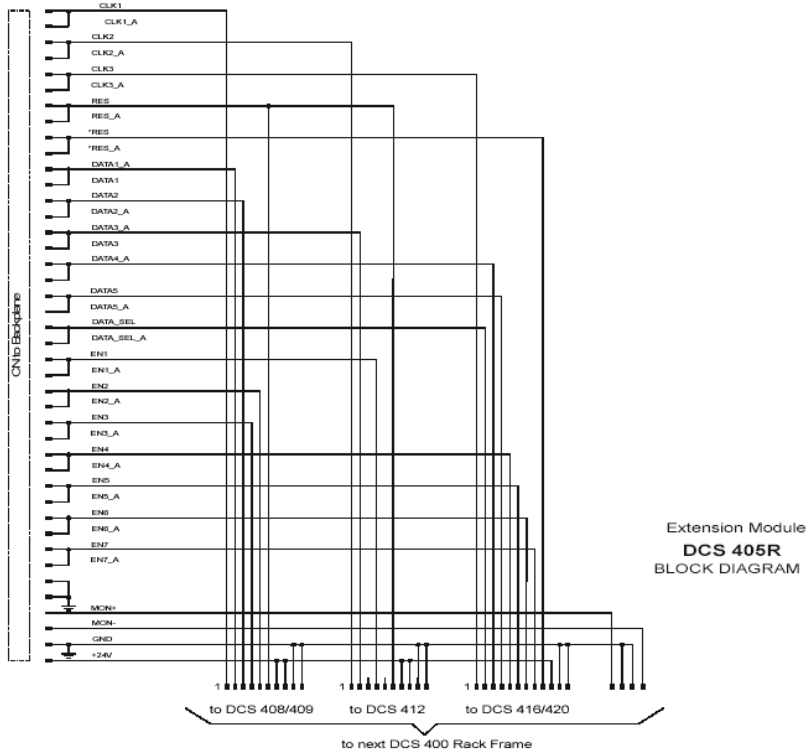

Block Diagrams:

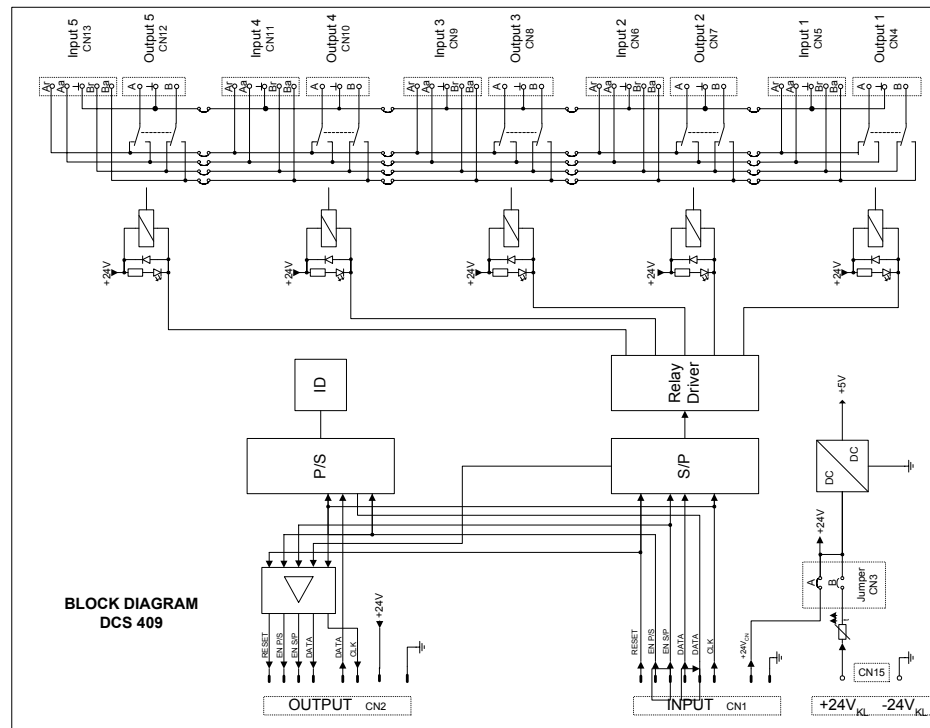
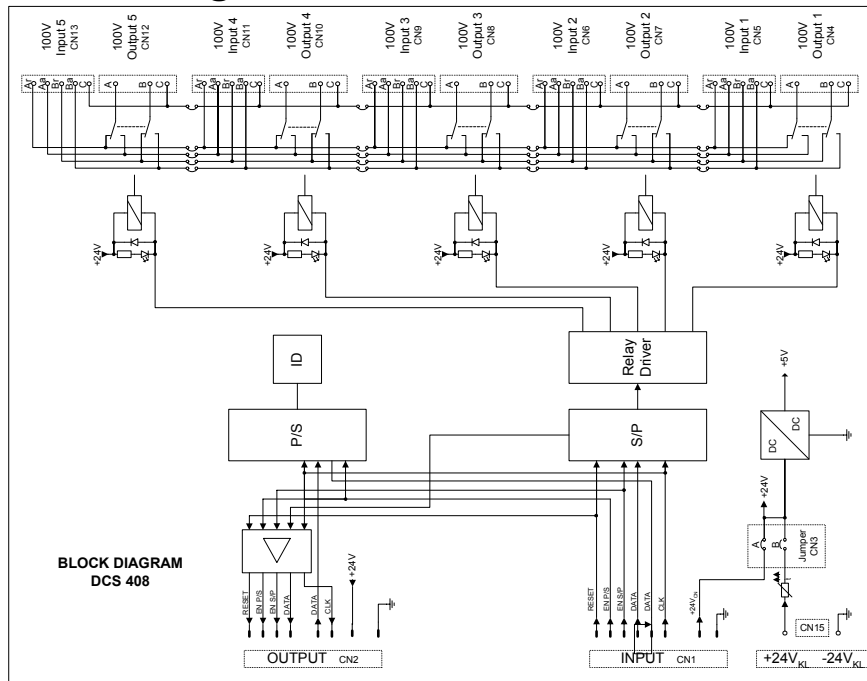

12000 Portland Av. South, Burnsville, MN 55337
 Phone: 952-887-4051, Fax: 952-887-0043

www.electrovoice.com

Telex Communications Inc 11/2002
 Part Number 38109-xxx Rev A

USA and Canada Only. For customer orders contact
 Customer Service at: 800/392-3497 Fax: 800/955-6831



Key Features:

- Self-monitoring with fault message output
- Password protection over several levels
- RS-232 interface for data backup and servicing purposes
- Integrated service and maintenance program software
- Expandable flash-memory
- Direct digital recording and reproduction of at least 100 different sound and speech signals.
- Maximum recording time up to 16 minutes.
- Maximum bandwidth is 16 kHz.
- 15 acoustical alarm signals and 6 different gong signals



General Description:

The DMM 4650 is a signal processor, capable of audio recording and playback, as well as, audio signal generation such as alarms. The main application is for PA racks, but stand-alone applications are possible as well. The audio signals can consist of alarm, gong, messages and also random combinations. These programs were created by Dynamacord and stored as presets.

The audio quality of the messages can be selected depending on memory extension and different user requirements. With maximum memory extension, a total recording time of 16 minutes is possible.

Password protection is provided. The operation is easy, like cassette recorders or CD players. A computer interface allows saving and loading of unit configurations and message data.

In order to ensure function reliability, a self-test and an audio data verification is installed. The alarm is provided via a dedicated output. The DMM 4650 does not require maintenance due to its use of flash memory.

Technical Specifications:

Operating Voltage	21.6 - 31.2V DC
Power consumption max.	18 watts (without retrofitting kits 90204)
Input voltage	0.775V/0dBu
Max. Input voltage	3.8V/+14dBu (Mic INPUT 50mV/ - 24dBu)
Input impedance	20kOhm (Mic INPUT 1.4kOhm)
Output voltage	0.775V/0dBu
Max. Output voltage	3.8V/+14dBu (Phones 9V/+21dBu)
Output impedance	(bal.) 136 Ohm, (unbal.) 68 Ohm
Frequency response	20Hz-20kHz -3/0dB
Signal-to-noise ratio	>108dB (A-weighted)
THD	< 0.03% (at 1kHz)
Data format AD/DA converter	16 bit linear
DSP internal	24 bit
Sampling rate	35kHz
Control inputs	< ± 5V = Low, > ±10V = High
Dimensions	483 X 43.6 X 225 (W x H x D) 19in, 1HU
Weight	4kg

Architecture & Engineering Specifications:

The message delivery unit shall provide universal generation and control of audio signals. The main application shall be for PA racks, but stand-alone applications are possible as well. The audio signals shall consist of alarm, gong, messages and also random combinations. The audio quality of the messages shall be selected depending on memory extension and different user requirements. With maximum memory extension, a total recording time shall be 16 minutes.

In order to ensure function reliability, a self-test and an audio data verification shall be installed. The fault alarm shall take place via a dedicated output. The utilize flash memory so as to be maintenance free.

Password protection shall be provided. The operation shall be simple, similar to cassette recorders or CD players. A computer interface shall be provided

allowing for saving and loading of unit configurations and message data.

Available Accessories:

Model	Cat. No.	Description
NRS90204	121647	Extension module 4 x I/O
NRS90205	121648	Memory expansion module
NRS90210	121650	Output transformer

Ordering Information:

Model	Cat. No.	Description
DMM4650	121675	Digital Message Manager



12000 Portland Av. South, Burnsville, MN 55337
Phone: 952-887-4051, Fax:952-887-0043
www.electrovoice.com
Telex Communications Inc 11/2002
Part Number 38109-xxx Rev A

USA and Canada Only. For customer orders contact
Customer Service at: 800/392-3497 Fax: 800/955-6831



Key Features:

- 200 or 400 watt output power is available.
- 70v or 100v capability for constant voltage speaker lines.
- Full remote control and monitoring functions available.(when used with optional remote modules).
- Integrated standby power supply.
- Remote-start function for mains and battery operation with inrush current limiter protection.
- Power-on noise attenuation.
- Status-LED indicators.
- LED meters with CLIP indication.
- Active, temperature-controlled ventilation.

General Description:

The DPA4120/40 amplifiers have been specially designed to ensure durable performance and reliable operation of sound reinforcement systems with several independent loudspeaker lines. The units are best suited for paging and pre-recorded message installations, alert systems, and for general music applications in industrial enterprises, offices, multi-function halls, sport arenas, schools, churches, hotels, hospitals, super markets, cruise ships, and similar venues.

The DPA4120/40 amplifiers can either be operated on the AC mains or connected to an external 24 V battery power source. Switching to battery operation is accomplished via an internal relay.

The DPA4120 and 4140 provides the following remote monitoring functions when used with the remote modules in a ProAnnounce system:

- Setting input levels
- Reading level values of the audio level controls.
- Setting level offsets via virtual controllers.
- Mute function (via level control).
- Remote control power operation ON/OFF.
- Battery operation remote control ON/OFF.
- Monitoring and fault message transmission of thermal overload warnings on the mains transformer or power output stages.
- Monitoring of the functioning of the power output stages via pilot tone signal.
- Ground fault detection for loudspeaker lines.

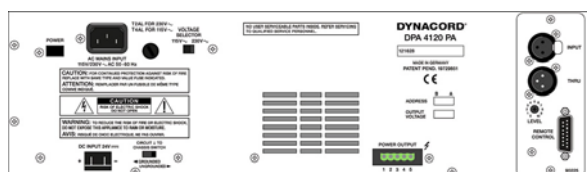

Technical Specifications:

Nominal output power with mains supply	1 x 200 or 1x400 W
Input characteristics:	Electronically balanced
Nominal input level	775 mV = 0 dBu / 10 k ohms
Power output characteristics:	Balanced, floating
Nominal output voltage -AC supply	100 V / 70 V / 50 V / 20 V
Nominal output voltage - battery supply at 24 V DC	79 V / 56 V / 40 V / 16 V
Nominal load impedance	100 ohms (50 / 25 / 4 ohms)
Noise (A-weighted)	-56 dBu
THD	<1 %
Frequency response	60 Hz to 20 kHz
Distortion-limited response (PA NOMINAL -3dB, kS = 1 %)	60 Hz to 5 kHz
Crosstalk	80dB at 1 kHz
MONITOR output characteristics:	Electronically balanced
MONITOR nominal output voltage	2 V = + 8.2 dBu
MONITOR nominal load impedance	600 ohms
MONITOR frequency response	60 Hz to 20 kHz
Operating temperature range	+5 °C to +40 °C
Dimensions	(W x H x D) 19" (483 mm) x 3HU (132 mm) x 345 mm
Installation depth without external connectors	340 mm
Installation depth incl. external connectors (max.)	400 mm
Weight	22.5 kg
Color	Anthracite

NRS90222 Remote Input Module

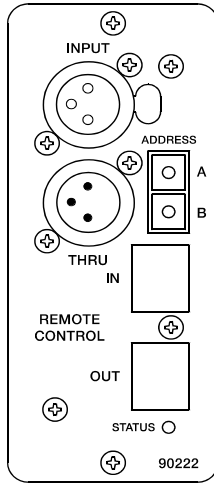

This single-channel input module provides DPA 4120 or DPA 4140 power amplifiers with remote functionality.

The module allows connecting balanced XLR-input and XLR-thru lines as well as connection to the remote control bus of the DPM 4000 (RS-485). Prior to connecting the amplifier to the operating voltage, the unit's address has to be set using the switches "A" and "B" (A=low value part)

The following remote functions are available:

Control:

Level control, Mute, Monitor activation (Input / Output), Mains

operation ON/OFF, Battery operation ON/OFF, Pilot tone ON/OFF (optionally available)

The following messages are available : Output level, Pilot tone detection, Ground fault detection, Thermal overload amplifier / mains transformer, Configuration, Measured values of current and voltage at the power output, Extension-kits

Available Accessories:

Model	Cat. No.	Description
NRS90206	121639	Pilot Tone Monitor module
NRS90222	121674	Remote Input Module
NRS90225	121677	Standard Input Module
NRS90207	121799	Ground fault monitor module
NRS90208	121641	Input transformer

Architecture & Engineering Specifications:

The remote control amplifier unit shall provide the following remote monitoring functions:

Setting input levels, reading level values of the audio level controls, setting level offsets via virtual controllers, mute function (via level controls), remote control power operation ON/OFF, battery operation remote control ON/OFF, monitoring and fault message transmission of thermal overload warnings on the mains transformer or power output stages, monitoring of the functioning of the power output stages via pilot tone signal, and ground fault detection for loudspeaker lines.

The amplifier shall either be powered by AC mains or connected to an external 24 V battery power source. Switching to battery operation shall be accomplished via an internal relay.

The amplifier shall be 3 RU in height and provide, 1x200, or 1x400 watt operation depending on the model. The output channel must be driven through on-board transformers.

The amplifier shall be the Dynacord ProAnnounce DPA4120 or DPA4140.

Ordering Information:

Model	Cat. No.	Description
DPA4120	121792	1x200 Power Amplifier
DPA4140	121793	1x400 Power Amplifier w/remote

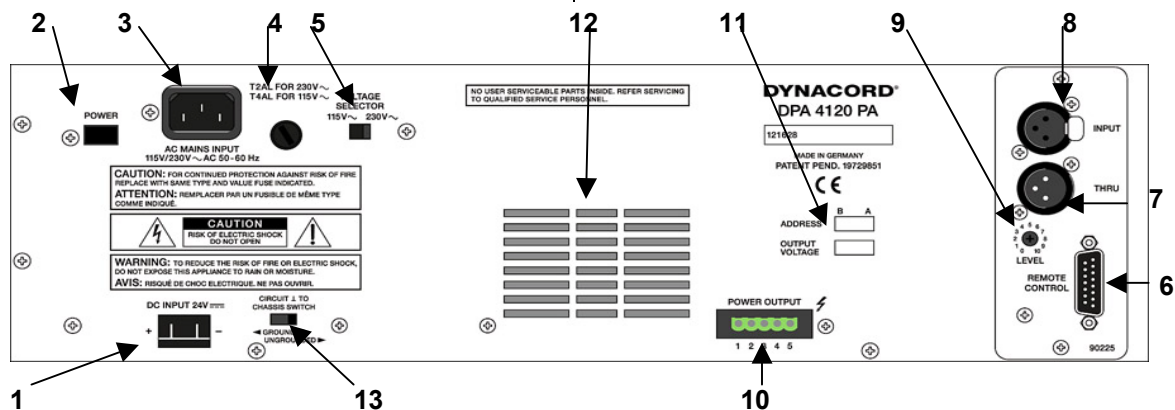

- | | |
|-----------------------------|--|
| 1 DC INPUT 24 V = | 8 INPUT connector |
| 2 POWER ON switch | 9 INPUT level |
| 3 AC MAINS INPUT connector | 10 POWER OUTPUT |
| 4 Mains fuse | 11 Device output configuration label field |
| 5 VOLTAGE SELECTOR switch | 12 Air outlets |
| 6 REMOTE CONTROL connectors | 13 CIRCUIT GROUND TO CHASSIS GROUND SWITCH |
| 7 Signal pass-thru | |

EV Electro-Voice®

12000 Portland Av. South, Burnsville, MN 55337

Phone: 952-887-4051, Fax:952-887-0043

www.electrovoice.com

Telex Communications Inc 11/2002

Part Number 38109-xxx Rev A

USA and Canada Only. For customer orders contact
Customer Service at: 800/392-3497 Fax: 800/955-6831



Key Features:

- Configurable as a 2x200, 2x100 & 1x200, or 4x100 amplifier.
- Operation with 70V loudspeaker networks or 4/8 ohms low-impedance systems
- Outputs protected against idling, short-circuits, over-temp and load variations.
- Integrated Remote Module for control and monitoring (DPA4411 only)
- Routing switch for parallel operation of the amplifier's inputs
- Integrated Standby Power Supply
- Remote-Start function for mains and battery operation with inrush current limiter protection.
- Power-on noise attenuation.
- Status-LED indicators.
- LED meters with CLIP indication.
- Active, temperature-controlled ventilation.

General Description:

The DPA4410/11 amplifiers have been specially designed to ensure durable performance and reliable operation of sound reinforcement systems with several independent loudspeaker lines. The units are best suited for paging and pre-recorded message installations, alert systems, and for general music applications in industrial enterprises, offices, multi-function halls, sport arenas, schools, churches, hotels, hospitals, super markets, cruise ships, and similar venues.

The DPA4410/11 amplifiers can either be operated on the AC mains or connected to an external 24 V battery power source. Switching to battery operation is accomplished via an internal relay.

The DPA4411 provides the following remote monitoring functions when used within a ProAnnounce system:

- Setting input levels on channels 1-4
- Reading level values of the audio level controls.
- Setting level offsets via virtual controllers.
- Mute function (via level controls).
- Remote control power operation ON/OFF.
- Battery operation remote control ON/OFF.
- Monitoring and fault message transmission of thermal overload warnings on the mains transformer or power output stages.
- Monitoring of the functioning of the power output stages 1 to 4 via pilot tone signal.
- Ground fault detection for loudspeaker lines.

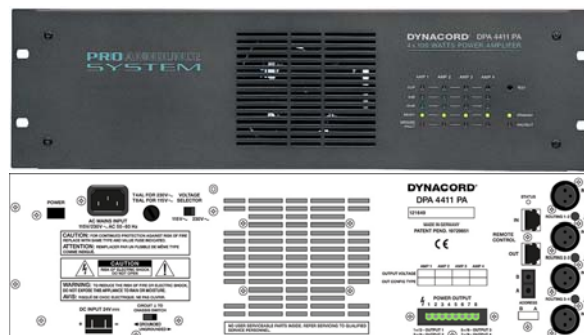

Technical Specifications:

Nominal output power with mains supply	4 x 100 W
Input characteristics:	Electronically balanced
Nominal input level	775 mV = 0 dBu / 10 k ohms
Power output characteristics:	Balanced, floating
Nominal output voltage -AC supply	100 V / 70 V / 50 V / 20 V
Nominal output voltage - battery supply at 24 V DC	79 V / 56 V / 40 V / 16 V
Nominal load impedance	100 ohms (50 / 25 / 4 ohms)
Noise (A-weighted)	-56 dBu
THD	<1 %
Frequency response	60 Hz to 20 kHz
Distortion-limited response (PA NOMINAL -3dB, kS = 1 %)	60 Hz to 5 kHz
Crosstalk	80dB at 1 kHz
MONITOR output characteristics:	Electronically balanced
MONITOR nominal output voltage	2 V = + 8.2 dBu
MONITOR nominal load impedance	600 ohms
MONITOR frequency response	60 Hz to 20 kHz
Operating temperature range	+5 °C to +40 °C
Dimensions	(W x H x D) 19" (483 mm) x 3HU (132 mm) x 345 mm
Installation depth without external connectors	340 mm
Installation depth incl. external connectors (max.)	400 mm
Weight	22.5 kg
Color	Anthracite

Architecture & Engineering Specifications:

The remote control amplifier unit shall provide the following remote monitoring functions:

- Setting input levels on channels 1-4
- Reading level values of the audio level controls.
- Setting level offsets via virtual controllers.
- Mute function (via level controls).
- Remote control power operation ON/OFF.
- Battery operation remote control ON/OFF.
- Monitoring and fault message transmission of thermal overload warnings on the mains transformer or power output stages.
- Monitoring of the functioning of the power output stages 1 to 4 via pilot tone signal.
- Ground fault detection for loudspeaker lines.

The amplifier shall either be powered by AC mains or connected to an external 24 V battery power source. Switching to battery operation shall be accomplished via an internal relay.

The amplifier shall be 3 RU in height and be configurable for 2x200, 1x200 & 2x100, or 4x100 watt operation. Jumpers located on the unit chassis shall

accomplish these operation mode changes. The output channels must be driven through on-board transformers.

The amplifier shall be the Dynacord ProAnnounce DPA4411 or DPA4410.

Available Accessories:

Model	Cat. No.	Description
NRS90206	121639	Pilot Tone Monitor module
NRS90207	121799	Ground fault monitor module
NRS90208	121641	Input transformer

Ordering Information:

Model	Cat. No.	Description
DPA4410	121792	4x100 Power Amplifier
DPA4411	121793	4x100 Power Amplifier w/remote

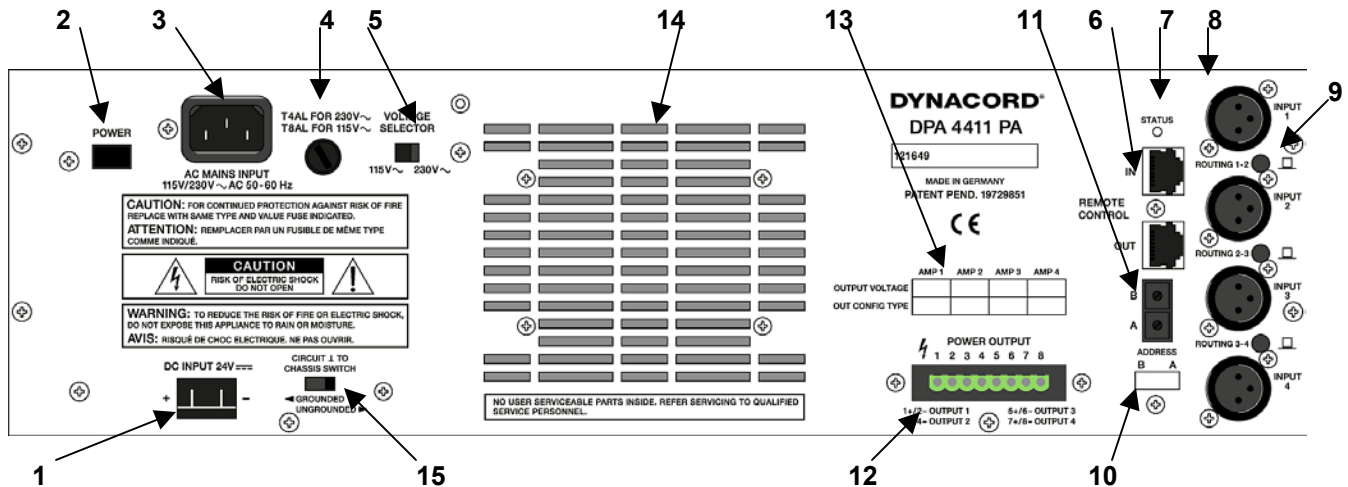

- 1 DC INPUT 24 V =
- 2 POWER ON switch
- 3 AC MAINS INPUT connector
- 4 Mains fuse
- 5 VOLTAGE SELECTOR switch
- 6 REMOTE CONTROL connectors
- 7 STATUS indicator
- 8 INPUT connectors 1-4

- 9 ROUTING switch for INPUT 1-4
- 10 Device address label field
- 11 ADDRESS selector switch
- 12 POWER OUTPUT
- 13 Device output configuration label field
- 14 Air outlets
- 15 CIRCUIT GROUND TO CHASSIS GROUND SWITCH



12000 Portland Av. South, Burnsville, MN 55337
 Phone: 952-887-4051, Fax: 952-887-0043
www.electrovoice.com
 Telex Communications Inc 11/2002
 Part Number 38109-xxx Rev A

USA and Canada Only. For customer orders contact
 Customer Service at: 800/392-3497 Fax: 800/955-6831



Key Features:

- All functions are processor-controlled
- Configuration data stored in non-volatile flash memory
- Condenser microphone including pre-amplifier and compressor / limiter
- Programmable key-assignment
- Easy labeling of keys via label-strips and MS WORD templates
- Monitoring of the analog circuitry via integrated pilot-tone oscillator
- Line-monitoring via pilot-tone and polling
- Covered alarm key (except at the DPC 4106)
- Set-up mode allows altering parameter settings directly at the paging station
- Two-line LCD display

General Description:

The ProAnnounce system includes 5 different paging station models and one paging station extension of the DPC 4000 - series. All paging stations employ gooseneck microphones, 6 or 8 function keys, and a covered alarm key. An additional key as well as a key-lock switch can be retrofitted. All paging stations are available with 10, 20, 30, or 50 selection keys. All models come with an LCD display (2 lines with 16 characters each).

The available models are:

- DPC 4106 with 6 function keys
- DPC 4510 with 8 function keys, 10 selection keys and an alarm key
- DPC 4520 with 8 function keys, 20 selection keys and an alarm key
- DPC 4530 with 8 function keys, 30 selection keys plus an alarm key
- DPC 4550 includes 8 function keys, 50 selection keys and one alarm key
- DPC 4350 paging station extension unit provides 50 additional selection keys to any paging station above.



DPC4520 Paging Station

Technical Specifications:

DPC MODEL	4106	4510	4520	4530	4550	4350
Operation voltage	24 V DC (21,6 V - 31,2 V)					
Power cons. (24 V) mA	80	80	85	90	90	90
Min. operation voltage	15 V DC					
Max. pwr cons. (15 V) mA	120	120	120	120	135	95
Audio input external						
Line (default)	0 dBu					
PTT - microphone	-52 dBu					
Audio output	+6 dBu					
Alarm Key	Opt.	Yes			N/A	
Display	2 x 16 digits (LCD)					N/A
Connection	RJ-45					
Cord length (ft.)	3.2					1.6
Enclosure DxH	160 x 65 mm					
Enclosure Width	170	225	270	320	405	335
Weight	1.0	1.5	1.7	1.8	2.5	1.9
Finish	Gray-White RAL9002, microstructure					

Architecture & Engineering Specifications:

The paging stations shall be processor-controlled and provide several monitoring functions. The units shall provide configuration data storage using non-volatile flash memory. The paging microphone shall be of the condenser type and include pre-amplifier and compressor / limiter. The paging station keys shall be programmable. The paging station keys shall be easy to label via label-strips and MS-WORD templates. The units must contain integrated watchdog circuitry to monitor the processor system while the audio section is guarded by the signal of a switchable pilot tone oscillator. Additionally, the internal supply voltage shall be constantly measured. Once it drops below a critical threshold, a warning signal must be being transmitted. Line-monitoring for the audio-cabling as well as for all RS-485 control-lines allows shall provide early recognition and signaling of line-interrupts and short-circuits. The configuration of the paging stations shall be accomplished via ProAnnounce Designer software. The software shall be a graphical, dialog-oriented user-interface allowing the setting of all key-functions, priorities, options, and several other parameters.

Available Accessories:

Model	Cat. No.	Description
NRS90209	121718	Monitor speaker
NRS90232	121722	I/O Transformer
NRS90231	121721	Keyed Switch
NRS90230	121720	Button/Switch

Ordering Information:

Model	Cat. No.	Description
DPC4106	121762	6 key paging console
DPC4510	121623	8 Function 10 key console
DPC4520	121624	8 Function 20 key console
DPC4530	121622	8 Function 30 key console
DPC4550	121625	8 Function 50 key console
DPC4350	121626	50 key expansion console

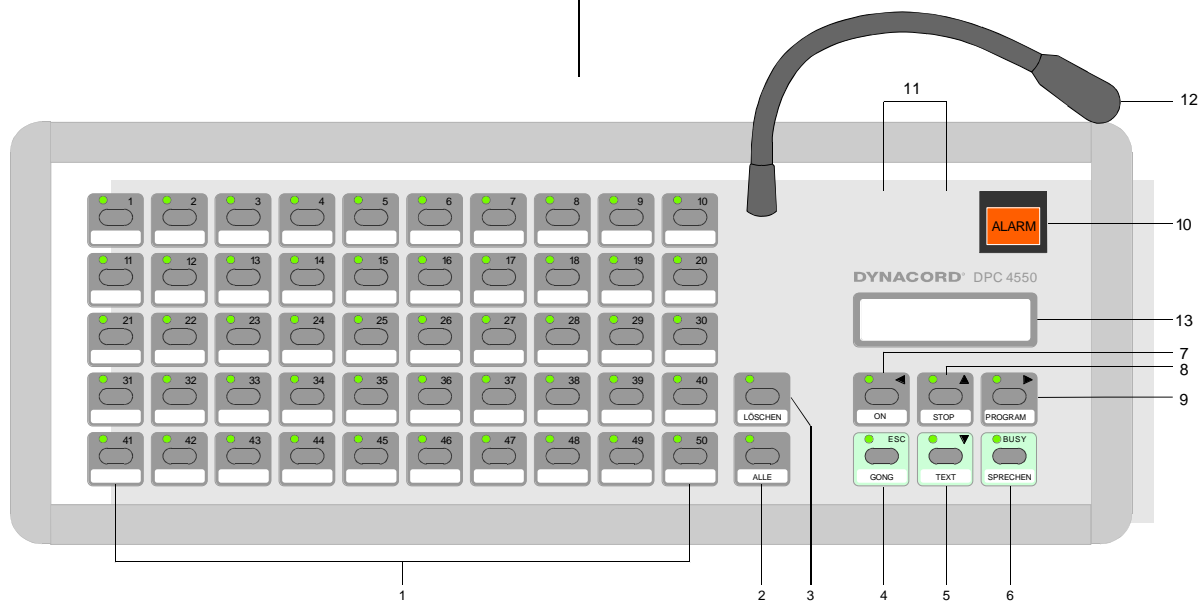

- | | | | |
|---|--|----|-------------------------|
| 1 | Selection keys (up to 50 depending on model) | 8 | Stop key |
| 2 | All key with LED | 9 | Program key |
| 3 | Cancel key | 10 | Alarm Key (covered) |
| 4 | "Gong" or "Chime" key | 11 | Space for optional keys |
| 5 | Text key for prerecorded messages | 12 | Microphone |
| 6 | Talk button with "busy" LED | 13 | LCD display |
| 7 | On key | | |

EV Electro-Voice®

12000 Portland Av. South, Burnsville, MN 55337
 Phone: 952-887-4051, Fax:952-887-0043

www.electrovoice.com

Telex Communications Inc 11/2002
 Part Number 38109-xxx Rev A

USA and Canada Only. For customer orders contact
 Customer Service at: 800/392-3497 Fax: 800/955-6831



General Description:

The DPM 4000 allows for audio connections and system expansion through the use of interface card modules. There are three basic types of modules available for the DPM4000. They are:

- Audio Input Modules
- Audio Output Modules
- GPIO Control Modules

Slots 1 and 2, located on the far right of the DPM 4000 (as viewed from the rear), are the DPM 4000's audio input module slots providing two audio inputs per slot. Each slot can be equipped with any suitable audio input module. The DPM 4000 is shipped with no audio input modules installed.

Slots 3 and 4, located to the left of slots 1 and 2, are the DPM 4000's audio output slots providing two audio outputs per slot. Each slot can be equipped with a 2-channel audio output module. The DPM 4000 is shipped with a 2-channel audio output module installed in slot 3 with slot 4 being left empty.

Slot 5, located to the left of slots 3 and 4, is a control slot, which can be equipped with control modules for general control and query purposes. Control modules provide different kinds of control inputs and outputs. The DPM 4000 is shipped with one 8 channel I/O control module installed.

In addition, an extension slot allows retrofitting additional serial ports, which can be used for the inter-communication amongst DPM 4000 managers or to connect additional external devices. For detailed information, please refer to the owner's manuals of the individual extensions or modules.

2-Channel Paging Station Module (NRS 90215)

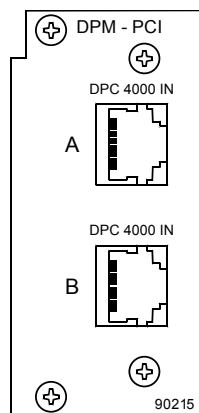

This 2-channel audio input module is meant for the connection of DPC 4000 Series paging consoles. Each of the two input channels provide RJ-45 sockets allowing the connection of up to 4 paging stations plus paging station extensions per input. The microphone terminals are interconnected via 6-conductor parallel cables. The module can be installed in slot 1 and slot 2. Next to the electronically balanced audio input, each input connector provides a serial RS-485 interface

port and the power supply connection for the paging stations (see also: pin-assignment of the RJ-45 connector). The paging stations' power supply employs an electronic, programmable fuse, through which the maximum output current can be matched to meet actual system accommodations. This prevents the entire installation from malfunction, in case of short-circuit occurring in a single paging station only. Input channels can be switched separately onto the monitor bus and you can monitor the audio signal via headphones or loudspeaker, either which is connected to the monitor output. Automatic pilot tone surveillance of the entire input stage is integrated as well. If necessary, retrofitting the audio inputs with transformers is possible.

Specifications:

connection	2 x RJ-45 sockets
inputs	2, electronically balanced
nominal input level	0 dBu / 775 mV
max. input level	+12 dBu / 3 V
input impedance	20 kΩ
input balancing	> -30 dB
frequency response	20 Hz ... 20 kHz, ± 0.5 dB
S/N ratio	> 100 dB (A-weighted)
distortion	< 0.01 %
A/D-conversion	18-bit linear, Sigma-Delta
control interfaces	2 x RS-485 standard
power supply outputs for the DPC 4000	2, short-circuit-proof, electronically programmable fuses
supply voltage	24 V DC (21.6 ... 31.2 V DC)
nominal current	330 mA, 660 mA, 990 mA (adjustable, electronic fuse)
power consumption	2 W
dimensions W x H x D	37.5 x 81 x 248 mm
weight	152 g

MIC/LINE + 2 AUX Input Module (NRS 90216)

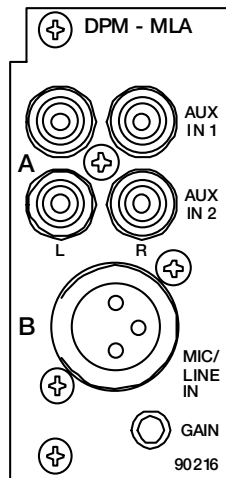

This 2-channel audio input module is meant for the connection of external audio sources of any kind. Channel A employs two switched AUX-inputs with 4 RCA-type connectors (2 x L / R) for CD players, tape decks, tuners, DAT decks, etc. The MIC / LINE-input of channel B is provided through an XLR F-type connector allowing the connection of microphones, mixers and other similar sources. The module can be inserted in slot 1 and slot 2. Input levels of both AUX-inputs can be separately

adjusted via internal potentiometers in a range between -10 dBu to $+12$ dBu. The MIC / LINE-input's sensitivity can also be adjusted through an internal MIC / LINE switch (PAD) providing 30 dB attenuation. The GAIN-control on the appliance's rear panel offers additional control within a range of 40 dB. The MIC / LINE input is electronically balanced and can be retrofitted with a transformer. Phantom power can be switched via a jumper. If necessary, it is also possible to incorporate a compressor/limiter into the audio path via jumper setting. The input channels can be switched separately to the monitor bus and you can listen to the signal via headphones or loudspeaker, either which is being connected to the monitor output. Automatic pilot tone surveillance of the entire input stage is integrated as well.

Specifications:

Connections	1 x XLRF-type / 4 x RCA-type connectors
Input A	2 x AUX, unbalanced, internally summed
nominal input level	-10 dBu ... $+12$ dBu / 250 mV ... 3 V
max. input level	$+12$ dBu / 3 V
input impedance	10 kW
input B	MIC/LINE, electronically balanced
nominal input level	MIC: -54 dBu ... -14 dBu / 1.5 mV ... 155 mV
	LINE: -24 dBu ... $+16$ dBu / 50 mV ... 5 V
max. input level	MIC: $+5$ dBu / 1.4 V
(in limiter operation)	LINE: $+30$ dBu / 25 V
input impedance	MIC: 3.6 kW, LINE: 10 kW
input balancing	> -30 dB
phantom power	24V / 20 mA, switched via jumper
frequency response	20 Hz ... 20 kHz, ± 0.5 dB
S/N ratio	> 95 dB (A-weighted)
distortion	< 0.01 %
A/D-conversion	18-bit linear, Sigma-Delta
power consumption	2.3 W
dimensions W x H x D	37.5 x 81 x 252 mm
weight	160 g

2-Channel MIC/LINE Input Module (NRS 90217)

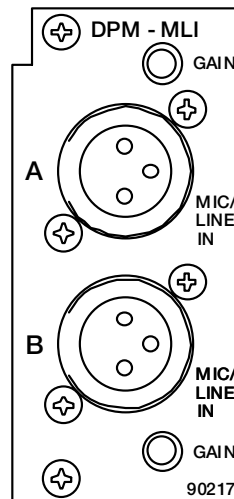

This 2-channel audio input module is meant for the connection of external audio sources, like microphones, mixers, etc. Both channels are furnished with XLR F-type connectors. The module can be installed into slot 1 and slot 2. The sensitivity of the MIC / LINE inputs can be adjusted in a wide range. The internal MIC / LINE switches (PADs) provide 30 dB attenuation. The separate GAIN-controls for each channel provide additional control in a range of 40 dB. The MIC / LINE inputs are electronically balanced and

can be retrofitted with transformers. Phantom power can be switched via jumper setting. If necessary, compressors / limiters can also be incorporated in the audio paths via jumpers. Input channels can be switched separately onto the monitor bus and you can listen to the signal via headphones or loudspeaker, either which is being connected to the monitor output. Automatic pilot tone surveillance of the entire input stage is integrated as well.

Specifications:

connections	2 x XLRF-type connectors
audio	
inputs	2 x electronically balanced
nominal input level	MIC: -54 dBu ... -14 dBu / 1.5 mV ... 155 mV
	LINE: -24 dBu ... $+16$ dBu / 50 mV ... 5 V
max. input level	MIC: $+5$ dBu / 1.4 V
(in limiter operation)	LINE: $+30$ dBu / 25 V
input impedance	MIC: 3.6 kW
	LINE: 10 kW
Input balancing	> -30 dB
phantom power	24V / 20 mA, switched via jumper
frequency response	20 Hz ... 20 kHz, ± 0.5 dB
S/N ratio	> 95 dB (A-weighted)
Distortion	< 0.01 %
A/D-conversion	18-bit linear, Sigma-Delta
phantom power	24V / 20 mA, switched via jumper
power consumption	3 W
dimensions W x H x D	37.5 x 81 x 252 mm
D	
weight	160 g

2-Channel AUX Input Module (NRS 90228)

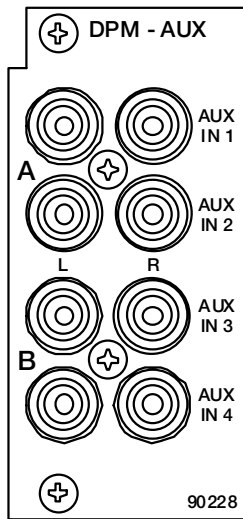

This 2-channel audio input module provides 8 RCA-type connectors (4 x L / R) for connecting external audio sources such as CD-players, tape decks, tuners, DAT decks, etc. The module can be installed into slot 1 and slot 2. The input levels of the four AUX inputs can be independently adjusted in a range between -10 dBu and +12 dBu via internal trim-potentiometers. Input channels can be switched separately to the monitor bus and you can listen to the signal via headphones or loudspeaker, either which

being connected to the monitor output. Automatic pilot tone surveillance of the entire input stage is integrated as well.

Specifications:

connections	8 x RCA-type connectors
inputs	4 x AUX, unbalanced, internally summed
nominal input level	-10 dBu ... +12 dBu / 250 mV ... 3 V
max. input level	+12 dBu / 3 V
input impedance	10 kW
frequency response	20 Hz ... 20 kHz, ± 0.5 dB
S/N ratio	> 100 dB (A-weighted)
distortion	< 0.01 %
A/D-conversion	18-bit linear, Sigma-Delta
power consumption	1.4 W
operational temperature range	+5 °C ... +40 °C
dimensions W x H x D	37.5 x 81 x 252 mm
weight	150 g

MIC/LINE + Paging Station Module (NRS 90234)

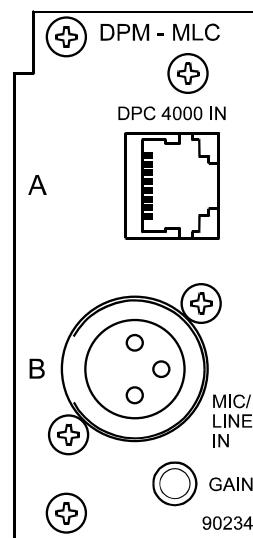

This 2-channel audio input module is meant for the connection of DPC 4000 Series paging stations and other external audio sources. The RJ-45 socket of channel A allows the connection of up to 4 microphone terminals plus paging station extensions. The MIC / LINE input of channel B is furnished through an XLR F-type connector allowing the connection of microphones, mixers and other audio signal sources. The module can be installed into slot 1 and slot 2. Next to the electronically balanced audio input, the DPC 4000 input connector

provides a serial RS-485 interface and the power supply for the connected paging consoles (see also pin-assignment of the RJ-45 connector). The MIC / LINE input employs an internal switch (PAD) providing 30 dB of attenuation. The GAIN-control located on the appliance's rear panel offers additional control in a range of 40 dB. The input is electronically balanced and prepared for retrofitting a transformer. Phantom power can be switched via jumper. If necessary, a compressor / limiter circuit can be incorporated in the audio path.

Specifications:

connections	1 x RJ-45 socket; 1 x XLR F-type connector
input A	DPC 4000, electronically balanced
nominal input level	0 dBu / 775 mV
max. input level	+12 dBu / 3 V
input impedance	20 kW
input B	MIC/LINE, electronically balanced
nominal input level	MIC: -54 dBu ... -14 dBu / 1.5 mV ... 155 mV LINE: -24 dBu ... +16 dBu / 50 mV ... 5 V
max. input level	MIC: +5 dBu / 1.4 V
(in limiter operation)	LINE: +30 dBu / 25 V
input impedance	MIC: 3.6 kW LINE: 10 kW
Phantom power	24V / 20 mA, switched via jumper
input balancing	> -30 dB
frequency response	20 Hz ... 20 kHz, ± 0.5 dB
S/N ratio	> 95 dB (A-weighted)
distortion	< 0.01 %
A/D-conversion	18-bit linear, Sigma-Delta
control interface	1 x RS-485 standard
supply output for the DPC 4000	1, short-circuit-proof, electronic, programmable fuse
supply voltage	24 V DC (21.6 ... 31.2 V DC)
nominal current	330 mA, 660 mA, 990
dimensions W x H x D	37.5 x 81 x 252 mm
weight	165 g

2-Channel LINE Output Module (NRS 90218)

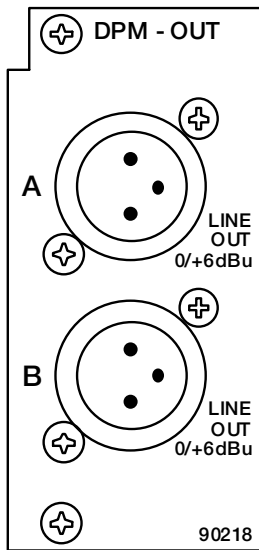

The output module is meant for the connection of power amplifiers with an input sensitivity of 0 dB or +6 dB. Two XLR M-type connectors allow the connection of up to 20 power amplifiers each. The audio signal is electronically balanced; if necessary, transformers can be retrofitted. The module can be installed in slot 3 or slot 4. The output channels can be switched separately to the monitor bus and you can listen to the signal via headphones or loudspeaker, either which is connected to the monitor output.

Automatic pilot tone surveillance of the two output

channels is also integrated. The jumpers for adjusting the output voltage to 0 dB or +6 dB are located on the printed board assembly. At the same time you have to alter the jumper setting of the monitor signal correspondingly. The output module employs integrated output relays that prevent switching noise from being heard. When switching the system on, the output signal is put through after the system is been initialized (power-on delay); the contacts are immediately interrupted when switching the power off.

Specifications:

connections	2 x XLRM-type connectors
outputs	2, electronically balanced, transformers are optionally available
nominal output level	0 dBu / 775 mV or +6 dBu / 1.55 V, switched via jumper
output impedance	115 W
frequency response	20 Hz ... 20 kHz, ± 0.5 dB
dynamic range	> 97 dB (A-weighted)
S/N ratio	> 109 dB (A-weighted)
distortion	≤ 0.005 %
D/A-conversion	20-bit linear, Sigma-Delta
power consumption	1.5 W
dimensions W x H x D	37.5 x 81 x 247 mm
weight	160 g

8 I/O Control Module (NRS 90219)

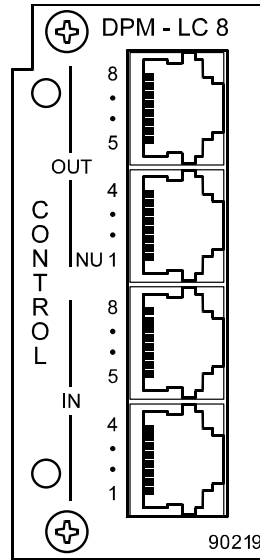

This control module provides 8 floating control inputs and 7 floating logic level outputs (0 V, 24 V). An additional output provides pole change impulses for controlling slave system clocks. Contact is established via 4 x RJ-45 sockets providing 8 contacts each. The module can be installed in slot 5. The slave clock output (NU, OUT 1) is short-circuit proof; up to approximately 40 slave clocks can be connected. Please make sure to connect all slave clocks according to their correct polarity. The control outputs (OUT 2 - 8) are capable of switching

voltages of either polarity and up to a maximum current of 1 A. The control inputs (IN 1 - 8) are capable of handling voltages of either polarity between -31 V and +31 V; for voltages between 0 and 5 V the inputs are not active (low), for voltages between 10 V and 31 V the inputs are active (high). The control inputs can ignite switching functions or macros either during a change of state or in any stationary state. This offers the possibility to monitor line idling currents (e. g. in fire alert system installations).

Specifications:

connections	4 x RJ-45 sockets
logic inputs	8, floating via opto-coupler, bi-polar
voltage when the input is LOW	UIN < ± 5 V
voltage when the input is HIGH	UIN > ± 10 V
maximum input voltage	UIN max = ± 31 V
logic outputs	7, floating via relay contacts
contact capacity	1 A / 24 V DC
slave clock output	pole change impulse / turning impulse
output voltage	24 V DC
maximum output current	500 mA, electronically protected against overload
power consumption	3.2 W
dimensions W x H x D	37.5 x 81 x 247 mm
weight	195 g

Available Accessories:

Model	Cat. No.	Description
NRS90227	121679	Output Transformer Line Balanced
		Line Balanced Input Transformer
		(1 pc. required per channel)
NRS90233	121682	Input Transformer Mic/Line

Ordering Information:

Model	Cat. No.	Description
NRS90215	121665	2 Input Paging Station Module DPC
NRS90216	121666	Input Module: Mic/Line + 2 x Aux
NRS90217	121667	Input Module: Mic/Line
NRS90218	121668	2 Channel Output Line Module
NRS90228	121680	Input Module: 2 Channel Aux (RCA Phono Connectors)
NRS90234	121736	Input Module: Combination Mic/Line + Paging Console

Block Diagrams:

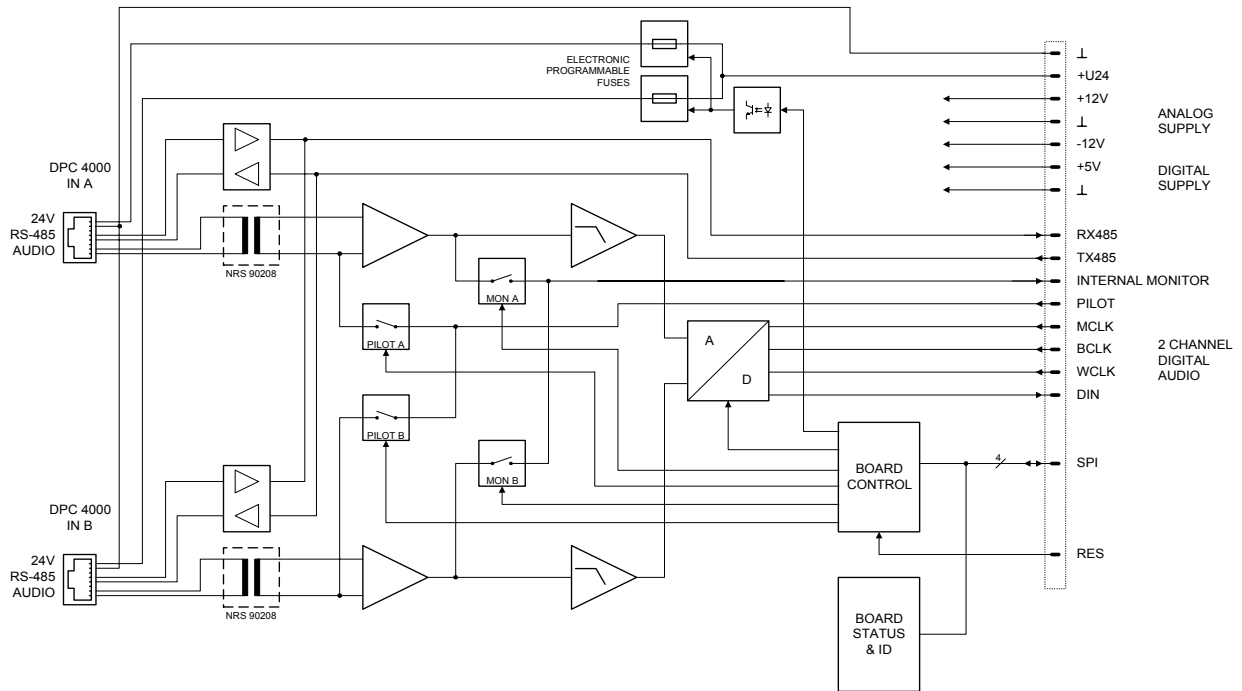

NRS90215 Block Diagram 1

Block Diagrams:

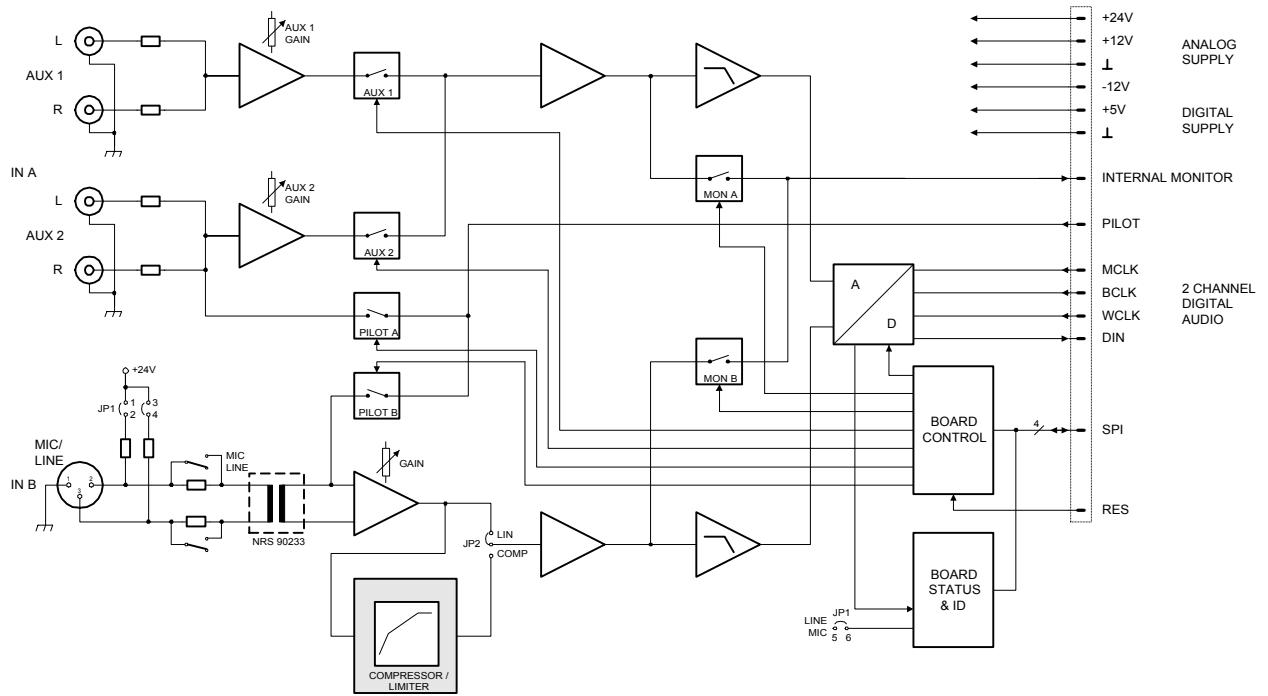

NRS90216 Block Diagram 1

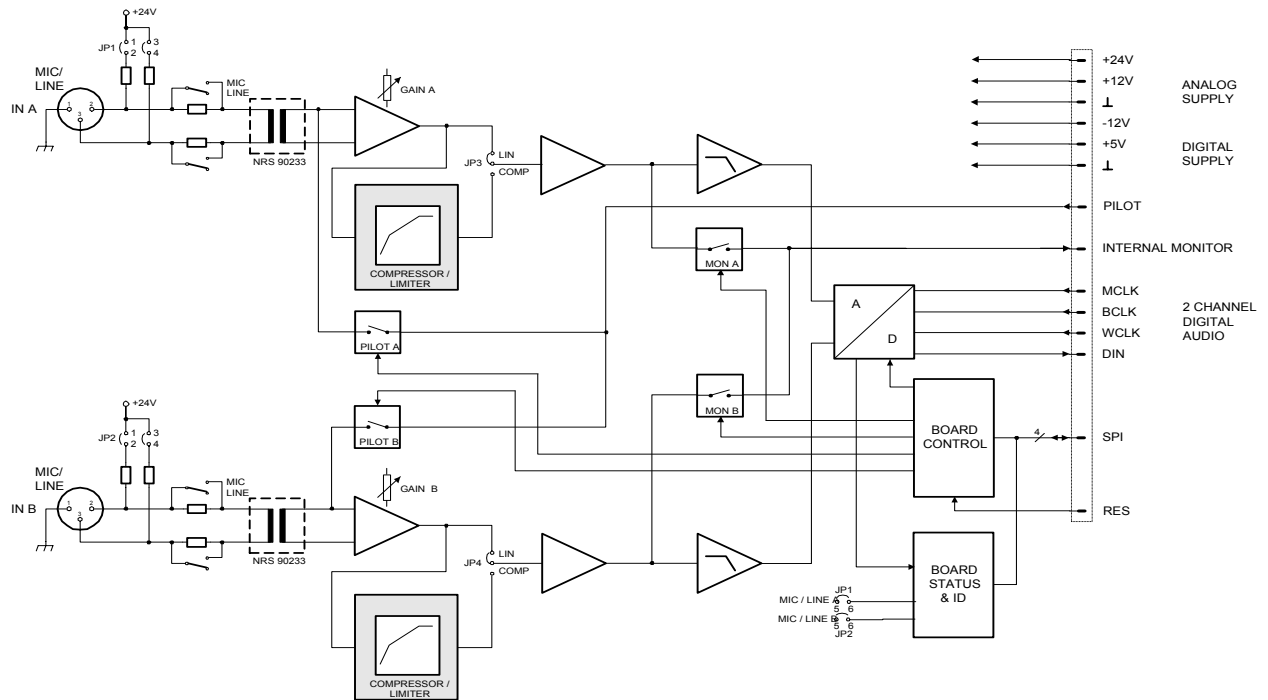

NRS90217 Block Diagram 1

Block Diagrams:

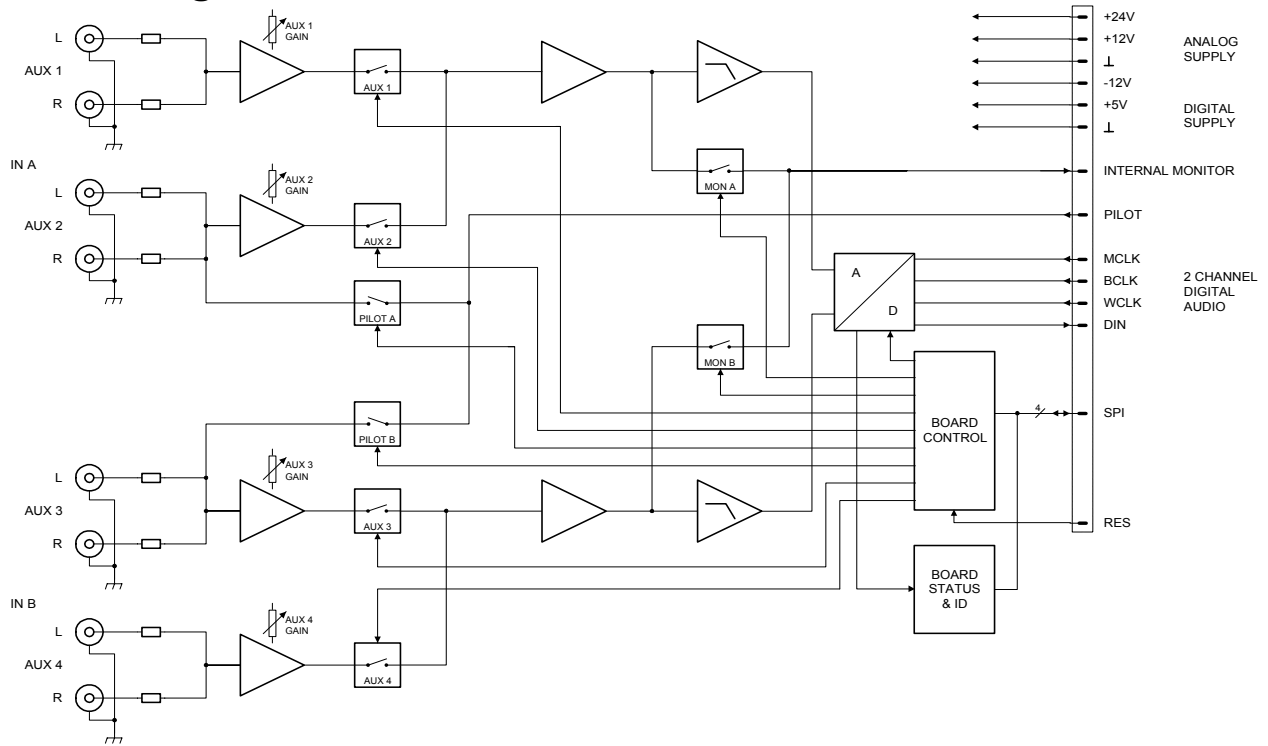

NRS90228 Block Diagram 1

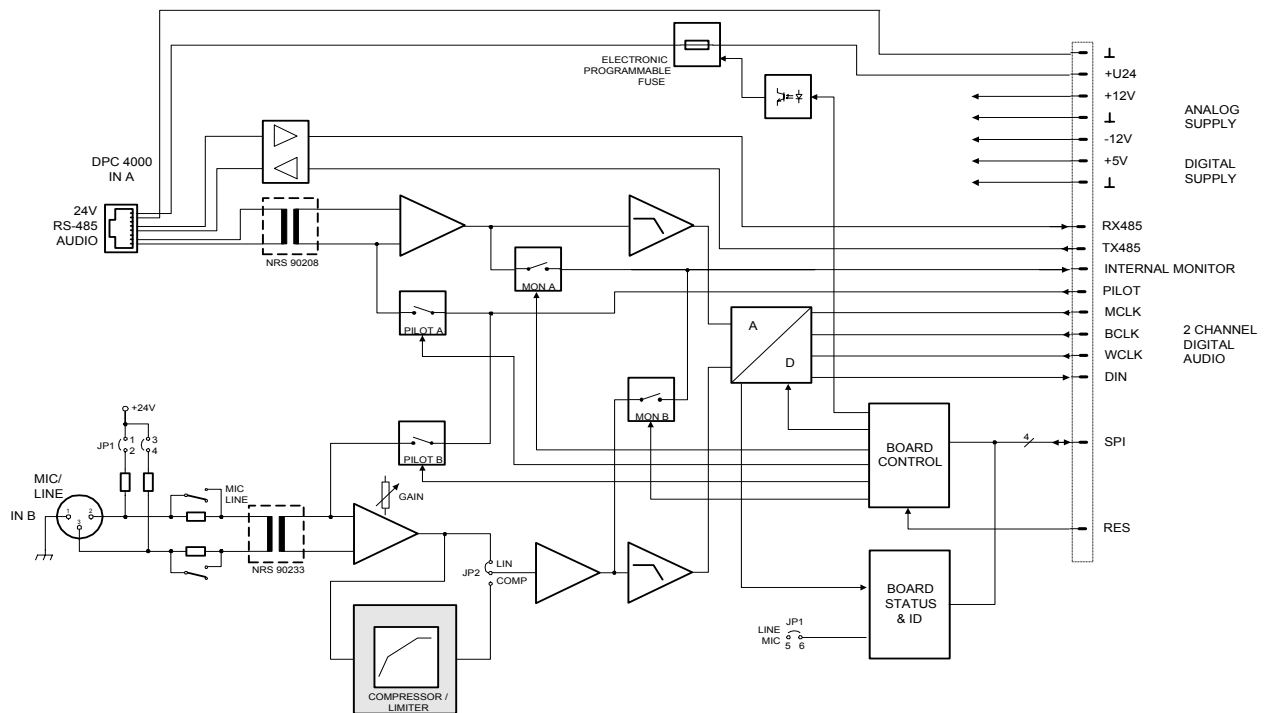

NRS90234 Block Diagram 1

Block Diagrams:

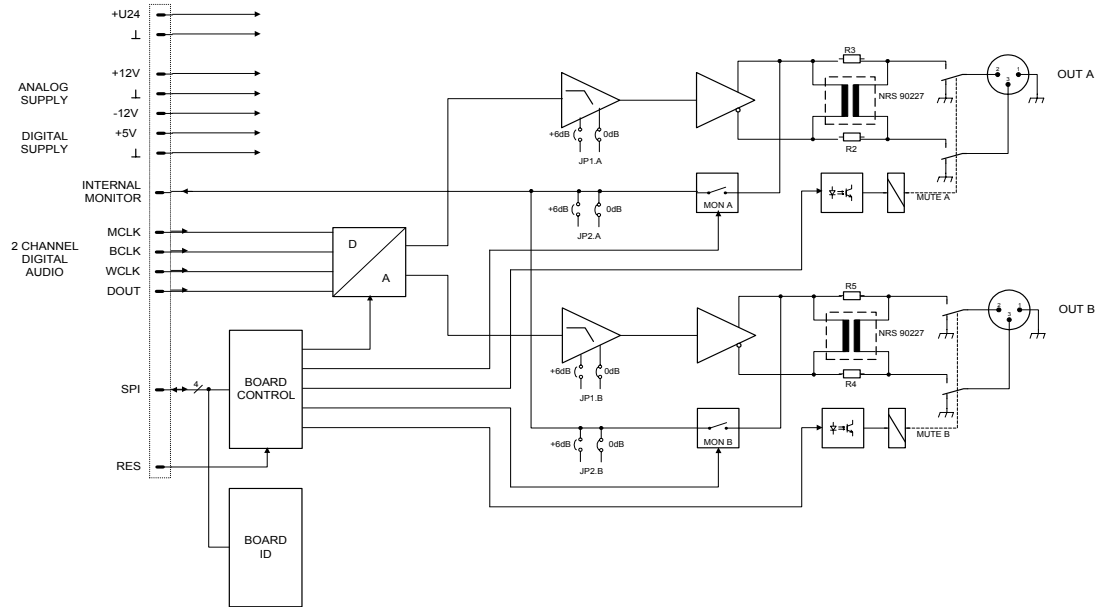

NRS90218 Block Diagram 1

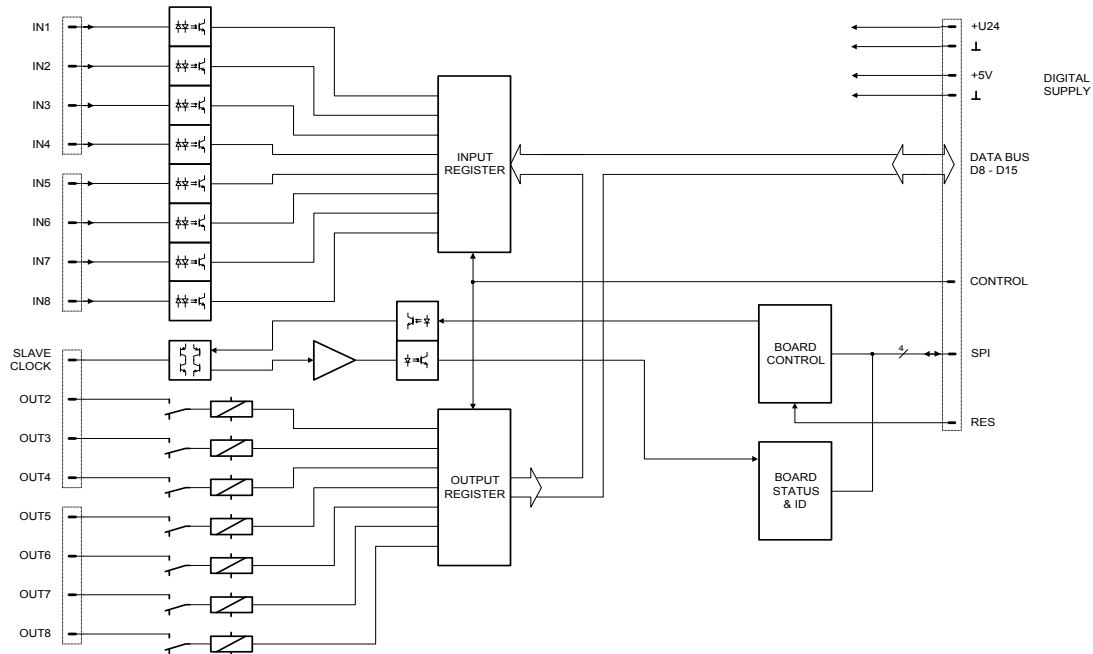

NRS90219 Block Diagram 1



12000 Portland Av. South, Burnsville, MN 55337
 Phone: 952-887-4051, Fax: 952-887-0043
www.electrovoice.com
 Telex Communications Inc 11/2002
 Part Number 38109-xxx Rev A

USA and Canada Only. For customer orders contact
 Customer Service at: 800/392-3497 Fax: 800/955-6831



Key Features:

- Digital 4 x 4 audio mixing matrix with level controls in all inputs and outputs
- Parametric 3-band equalizer for all 4 inputs
- Delay processor for all 4 outputs (optional)
- Multi-chime gong signal (optional)
- Alarm generator (optional)
- Signal generator and evaluation used for pilot tone surveillance
- Voice message recording and playback (optional)
- General purpose inputs
- General purpose outputs
- Linking of internal and external control inputs and outputs
- Monitoring facility for all inputs and outputs as well as DPA 4000 Series power amplifiers and other external audio sources.

General Description:

The DPM 4000 represents the paging management / control unit of the ProAnnounce system incorporating all primary functions that are needed in advanced PA-system installations.

The DPM 4000 employs a digital audio matrix providing four inputs and four outputs. Additional matrix junctions for the integrated gong and alarm signal generators, the vocal recording/playback unit, and the lock-on of the pilot tone and its evaluation are incorporated. All input signals and internally generated signals can be mixed inside the matrix and sent to the four output channels. Simple four-zone paging systems can be constructed using direct routing of output channels to dedicated zone amplifiers. More complicated (larger than four zone) systems can be constructed by using a system controlled relay matrix either pre- or post- amplifier. The DPM 4000 provides priority control of pages and other functions.

The DPM 4000 provides a variety of tone generators for the generation of gong, alarm, and pre-recorded messages. Signal generation is realized through DSP-algorithms, which are extremely flexible in use, so that they can be adjusted to match nearly any possible application. Factory presets include 6 different gong signals and 17 different alarm signals.



Technical Specifications:

Supply voltage	24 V DC (21.6 ... 31.2 V DC)
Nominal power cons.	500 mA
Maximum power cons.	6.7 A
Frequency Response	20 Hz ... 20 kHz, ± 0.5 dB
S/N ratio	> 100 dB (A-weighted)
Distortion	< 0.01 %
24 V output	24 V DC / 400 mA max. (21.6 ... 31.2 V DC)
Ready output	Floating relay contacts, 1 A / 24 V DC
Logic inputs	2, floating via opto-coupler, bi-pole
Maximum input voltage	UIN max = ± 31 V
RS-232 interface	19,200 Baud, 8 data bits, 1 stop bit, no parity, Xon/Xoff
Serial port	RS-485 standard
Supply output	Short-circuit protected, electronically programmable fuse
Supply voltage	24 V DC (21.6 to 31.2 V DC)
Nominal current	330 mA, 660 mA, 990 mA (selectable, electronic fuse)
Monitor input	Electronically balanced
Nominal input level	+2.2 dBu / 1 V
Max. input level	+10 dBu / 2.5 V
Input balance	> -30 dB
Monitor output	6.3 mm phone jack, either for the connection of headphones or speakers
Output level	Headphones: 650 mV / -1.5 dBu, Loudspeakers: 1.8 V / 7.2 dBu
Output power handling	Headphones: 50 mW / 8 Ω, Loudspeakers: 380 mW / 8 Ω
Operating temp.	+5 °C to +40 °C
Dimensions W x H x D	19", 2 HU 483 x 88 x 337 mm
Installation depth	340 mm (410 mm incl. connectors)
Weight	6.4 kg

Architecture & Engineering Specifications:

The unit shall employ a digital audio matrix providing four inputs and four outputs. Additional matrix junctions for the integrated gong and alarm signal generators, the vocal recording/playback unit, and the lock-on of the pilot tone and its evaluation shall be incorporated. All input signals and internally generated signals shall be capable of being mixed inside the matrix and sent to any of four channels. More complicated (larger than four zone) systems shall be capable of being constructed by using a system controlled relay matrix either pre- or post- amplifier. The unit shall provide priority control of pages and other functions.

The unit shall provide a variety of tone generators for the generation of gong, alarm, and pre-recorded message signals. Signal generation shall be realized through DSP-algorithms, which are extremely flexible in use, so that they can be adjusted to match nearly any possible application. The unit shall provide factory presets which will include 6 different gong signals and 17 different alarm signals.

The unit shall accept a variety of different input cards, which enable it to function with microprocessor, controlled paging stations, stereo line level input sources, and balanced mic / line level input sources.

The unit shall also be able to be expanded through the use of an expansion accessory.

The unit shall be the Dynacord ProAnnounce DPM4000.

Available Accessories:

Model	Cat. No.	Description
NRS90215	121665	Input module – 2 DPC
NRS90216	121666	Input module – mc/line + aux
NRS90217	121667	Input module – 2 mic/line
NRS90228	121680	Input module – 2 aux
NRS90234	121736	Input module – mic/line + DPC
NRS90218	121668	Output module – XLR line
NRS90205	121648	Message Memory module
NRS90227	121679	Output transformer
NRS90208	121641	Input transformer

Ordering Information:

Model	Cat. No.	Description
DPM4000	121795	4x4 Digital Matrix CPU

Block Diagram:

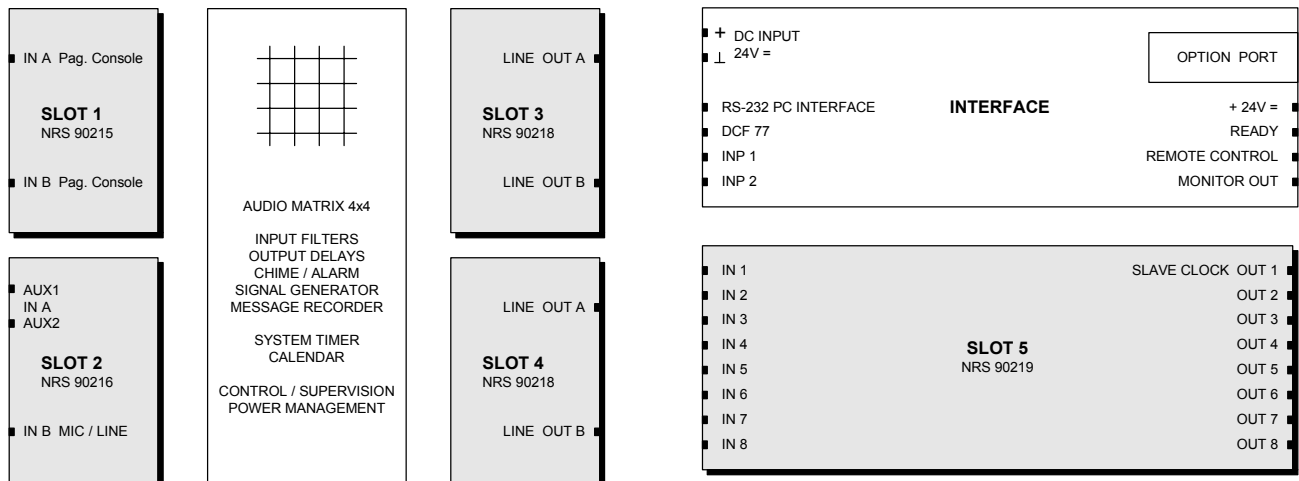

12000 Portland Av. South, Burnsville, MN 55337
 Phone: 952-887-4051, Fax: 952-887-0043
www.electrovoice.com
 Telex Communications Inc 11/2002
 Part Number 38109-xxx Rev A

USA and Canada Only. For customer orders contact
 Customer Service at: 800/392-3497 Fax: 800/955-6831



Key Features:

- 4 XLR MIC/LINE input channels, 4 stereo RCA-type AUX input channels.
- 2 XLR audio outputs.
- Level and tone control (Lo/Hi) in all input channels.
- Input channels can be independently assigned to the output channels and controlled via contact closures.
- Direct outputs for all MIC/LINE and AUX-channels. Pre/Post internally configurable.
- Priority control (ducking function) in the inputs MIC/LINE 1 and 2.
- Limiter in the inputs MIC/LINE 1 and 2 with internally selectable threshold.
- Separate summing controls for both outputs.
- VCA's in both output channels.
- Remote control via 8 external contacts:
- Optional RS-485 or RS-232 serial interface for connecting the DPM 4000 or a PC.

General Description:

The DRM 4000 is a rack-mixer and/or audio signal router offering eight audio inputs and two audio outputs. The inputs are divided into 4 MIC/LINE channels and four AUX channels. Each input channel can be freely assigned to either one or both output channels, offering mono two-channel operation, as well as, stereo operation modes.

The DRM 4000 can be used as a pre-mixer for the DPM 4000, expanding the amount of available input channels. DRM 4000 and DPM 4000 can be linked via an RS-485 remote-interface. Priority functions, preset switching and routing are easy to configure and operate.

The DRM 4000 Mixer & Router can also be used as stand-alone unit for simple sound reinforcement tasks, e.g. in a multimedia set-up, as well as for straightforward paging installations. Typical applications include the use as a mixer for sound reinforcement systems in conference rooms, multi-purpose facilities, clubs, restaurants, houses of worship, etc.



Technical Specifications:

Supply Voltage	24 V DC (21.6 to 31.2 V DC)
Nom. Power Consumption	(24 V) 700 mA
Max. Power Consumption	(24 V) 975 mA
Audio Inputs	4 x MIC / LINE, 4 x AUX, 1 X MIX IN
MIC/LINE Inputs	XLR-type connectors
Nom. Input Level	MIC: -60 to -10 dBu / 0.8 mV to 245 mV
	LINE: -30 to +20 dBu / 25 mV to 7.75 V
Max. Input Level	MIC: +11 dBu / 2.75 V
	LINE: +30 dBu / 24.5 V
Input Impedance	MIC: 3.6 k ohms
	LINE: 10 k ohms
Common Mode Rejection	> 50 dB
Limiter Operating Range	-10 dBu to +20 dBu (MIC/LINE 1 & 2)
AUX Inputs	2 x RCA-type connectors each, unbalanced
Nom. Input Level	-6 dBu respectively +4 dBu / 390 mV respectively 1.23 V
Max. Input Level	+15 dBu respectively +25 dBu / 4.4 V respectively 13.8 V
Input Impedance	> 19 k ohms
MIX Input	2 x RCA-type connectors, unbalanced
Nom. Input Level	0 dBu / 775 mV
Max. Input Level	+21 dBu / 8.7 V
Input Impedance	22 k ohms
Audio Outputs	
Master Output	A/B XLR-type connectors
Nom. Output Level	0 dBu / 775 mV
Max. Output Level	+21 dBu / 8.7 V
Output Impedance	< 120 ohms
Nom. Load Impedance	600 ohms
Send Output	2 x RCA-type connectors, unbalanced
Nom. Output Level	0 dBu / 775 mV
Max. Output Level	+21 dBu / 8.7 V
Output Impedance	< 100 ohms
Direct Outputs	Phoenix type terminal, unbalanced
Nom. Output Level	0 dBu / 775 mV
Max. Output Level	+21 dBu / 8.7 V
Output Impedance	< 100 ohms
Frequency Response	20 Hz - 20 kHz (-1.0 dB)
S/N Ratio	> 100 dB
THD MIC/LINE	< 0.03 %
THD AUX	< 0.01 %
Tone Control	LO ± 15 dB / 60 Hz
	HI ± 15 dB / 13 kHz
Low Cut	85 Hz / 12 dB per octave slope
Environmental temperature	+5°C to +40°C
Dimensions	483 x 43.6 x 351 (W x H x D in mm), 19", 1HU
Weight	10.4 lbs / 4.7 kg

Architecture & Engineering Specifications:

The rack-mixer / audio signal router shall offer eight audio inputs and two audio outputs. The inputs will be divided into four MIC/LINE channels and four AUX channels. Each input channel shall be independently assignable to either one or both output channels, offering mono two-Channel operation as well as stereo operation modes.

The unit shall be enabled for use as a pre-mixer for the DPM 4000, expanding the amount of available input channels. The DRM 4000 shall be capable of RS-485 communications with the DPM 4000. Priority functions, preset switching and routing shall be easy to configure and operate.

The unit shall also be enabled for use as a stand-alone unit for simple sound reinforcement tasks, e.g. in a multimedia set-up, as well as, for straightforward paging installations. The unit shall have four AUX input channels: each with two RCA-type connectors, volume and tone control (Lo/Hi) in all input channels, signal / peak LEDs (green / red) for monitoring the input level in all input channels and direct outputs for all MIC/LINE and AUX-channels. The unit shall also have priority control (ducking function) in the inputs MIC/LINE 1 and 2; and be controllable via external contacts, signal level with adjustable threshold (on the

front) or via remote control, indicated via LED's on the front panel. There shall be VCA's in both output channels providing two VCA control inputs A / B for remotely controlling the volume setting via external potentiometer, and also controllable via serial interface (PC, DPM 4000, media-control) or via control contacts. In addition there shall be remote control functionality via external contacts: eight independently configurable control inputs for ducking MIC/LINE 1 and 2, preset switching, routing, volume switching, mute.

Available Accessories:

Model	Catalog No.	Description
NRS90227	121679	Output xformer
NRS90233	121682	Input xformer
NRS90256	121785	RS435 interface
NRS90258	121790	PC interface

Ordering Information:

Model	Catalog No.	Description
DRM4000	121784	8x2 Mixer/Router

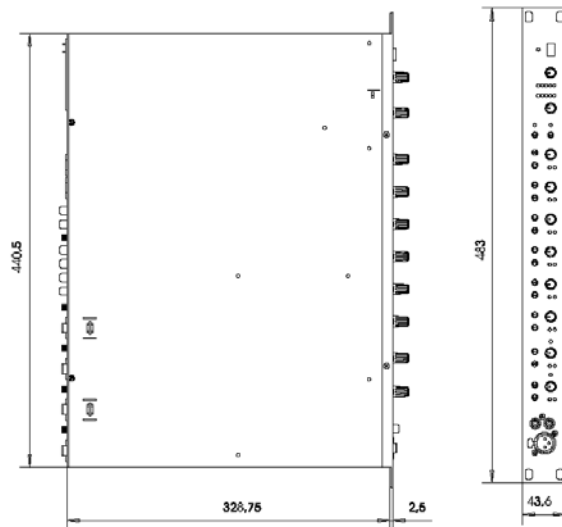
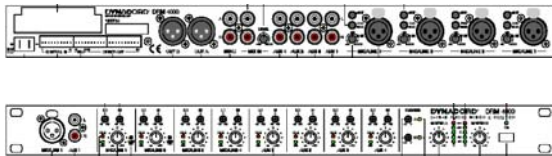

12000 Portland Av. South, Burnsville, MN 55337
 Phone: 952-887-4051, Fax:952-887-0043
www.electrovoice.com
 Telex Communications Inc 11/2002
 Part Number 38109-xxx Rev A

USA and Canada Only. For customer orders contact
 Customer Service at: 800/392-3497 Fax: 800/955-6831



Key Features:

- 100 zones available
- Up to 20 calling groups
- Selection of multiple zones or groups for announcements
- Prerecorded message triggering (message playback)
- Special function triggering (macros)
- Programmable priority
- Two-level password protection
- Acknowledgement signals
- Automatic hang-up
- Front panel audio level control

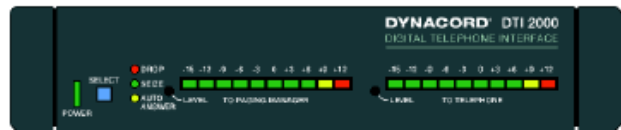

General Description:

The DTI 2000 is a microprocessor-controlled, configurable telephone interface that allows a ProAnnounce System to be connected to a telephone installation or the phone network. The DTI 2000 provides the user with a full functioning paging interface over a standard analog line. Remote triggering of signals, prerecorded messages and control functions (macros) within the ProAnnounce system are also possible via the DTI 2000.

The DTI 2000 uses DTMF tones and audio beeps to interact with the user. Two levels of password protection are provided to prevent unauthorized access to system functions. Audio from the caller is metered and adjusted from the front panel.

Technical Specifications:

Audio Output Level	0 dBu to + 20dBu
S/N-Ratio	> 60 dB
Frequency Response	300 Hz- 3.8 kHz (+0 / -6 dB)
Telephone Jack Socket	2 x RJ-11 (Loop-Thru)
DPM 4000 Interface	RJ-12, DB-9 female
Power Requirements	100-240 VAC, 50/60 Hz, 1 A
Dimensions (W x H x D)	8.19 x 1.73 x 7.99 inches
	208 x 44 x 203 mm
Weight	4.41 lb (2.0 kg)

Architecture & Engineering Specs:

The telephone paging interface shall provide the same functions and programmability as a DPC 4000 series paging station. It shall connect to a standard analog (POTS) line or equivalent service. It shall have audio and RS-485 connections that use the standard DPC connector on the DPM 4000PA paging controller. The unit shall provide password protection. It shall provide acknowledgement signals and control via DTMF tones. It shall automatically hang-up after a call is completed. The interface shall be configurable for various telephone systems. The unit shall be the DTI 2000 telephone interface.

Ordering Information:

Model	Description	Cat. No.
DTI-2000	Main Unit	121813
MCP1	Dual Rack Mount	90027728000
MCP2	Single Rack Mount	90027728001

Block Diagram:

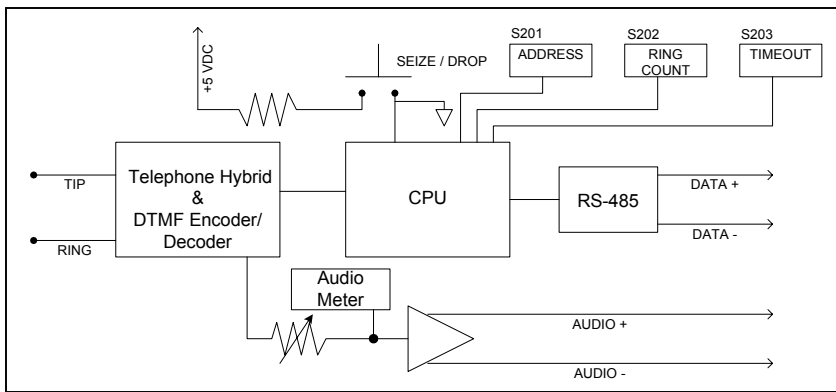

Dimension Drawings:

