

HP94S

TransPlanar™
Constant-Directivity
Horn



General Product Description

The Electro-Voice® model HP94S is a wide-range, flat-front, high-frequency, constant-directivity horn. Excellent loading is maintained to a low frequency of 1000 Hz.

The flat-front design makes the HP94S suitable for all modern boxed and clustered systems. A special vaned waveguide throat detail gives the HP94S unusually good high-frequency control, vertically, when compared to similar 2-inch-throat horn designs.

Architects' and Engineers' Specifications

The horn shall be of the constant-directivity type. It shall produce a horizontal nominal beamwidth (6 dB-down angle) of 90 degrees. It shall produce a vertical nominal beamwidth of 40 degrees. In addition, it shall provide useful acoustic loading at all frequencies above 1000 Hz.

The horn shall be of hybrid fiberglass-and-zinc construction. The driver-mounting flange and initial throat section shall be constructed of die-cast zinc and shall be integrally laminated into the fiberglass portion of the horn.

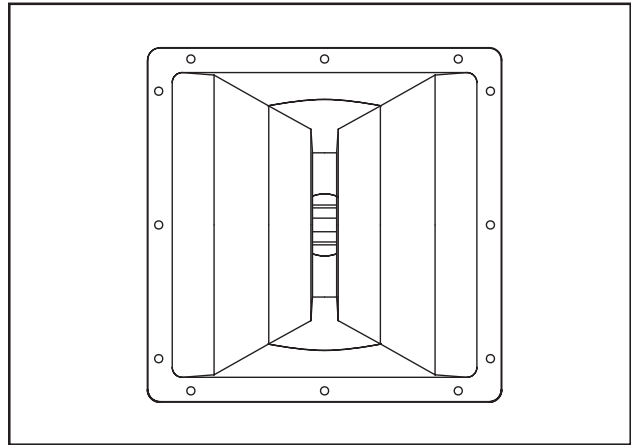

The horn shall possess a throat of 4.92-cm (1.94in.) diameter and its flange shall be provided with four 1/4-20 clearance bolt holes on a 10.2 cm (4.0 in.) circle for the mounting of the compression driver. The horn shall be 27.9 cm (11.0 in.) high, 22.2 cm (8.8 in.) wide, and 22.2 cm (8.7 in.) long. It shall weigh no more than 2.5 kg (4.5 lb).

The horn shall be the Electro-Voice model HP94S constant-directivity horn.

Specifications:

The following specifications are in accordance with or exceed the AES Recommended Practice for Specification of Loudspeaker Components Used in Professional Audio and Sound Reinforcement (AES2-1984; ANSI S4.26-1984).

Horizontal Beamwidth:

90°

Vertical Beamwidth:

40°

Directivity Factor R_0 (Q):

10.1

Directivity Index D_i :

10.1 dB

$10 \log R_0$

Lowest Recommended Crossover Frequency:

1000 Hz

Construction:

Polyester resin and glass-fiber laminate integrally molded to a die-cast zinc throat section. This hybrid construction assures a rigid driver mount, accurate, loss-free throat-wave transmission and low total weight compared to horns of similar size.

Mechanical Connection of Driver:

Bolt on; standard 2" diameter throat, 5" diameter mounting flange and four clearance holes for 1/4" bolts on a 4" diameter bolt circle.

Recommended Driver:

DH1A, DH2A

Weight:

2.5 kg (4.5 lb)

Dimensions:	Inches
A	1.938
B	5.00
C	11.00
D	11.00
E	4.00
F	0.281 x 4
G	8.68
H	8.43

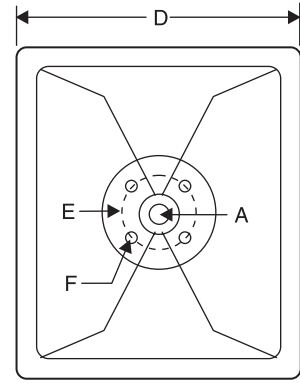
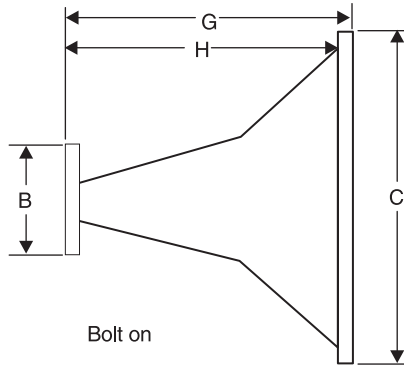

Figure 1: Dimensions

USA 12000 Portland Ave South, Burnsville, MN 55337, Phone: 952-884-4051, FAX: 952-884-0043
Canada 705 Progress Avenue, Unit 46, Scarborough, Ontario, Canada, M1H2X1, Phone: 416-431-4975, 800-881-1685, FAX: 416-431-4588
Germany Hirschberger Ring 45, D94315, Straubing, Germany, Phone: 49 9421-706 0, FAX: 49 9421-706 287
France Parc de Courcerin, Alle Lech Walesa, Lognes, 77185 Marne La Vallee, France, Phone: 33/1-6480-0090, FAX: 33/1-6480-4538
Australia Unit 23, Block C, Slough Business Park, Slough Avenue, Silverwater, N.S.W. 2128, Australia, Phone: 61/2-9648-3455, FAX: 61/2-9648-5585
Hong Kong Unit E & F, 21/F, Luk Hop Industrial Bldg., 8 Luk Hop St., San PO Kong, Kowloon, Hong Kong, Phone: 852-2351-3628, FAX: 852-2351-3329
Japan 5-3-8 Funabashi, Setagaya-ku, Tokyo, 156-0055 Japan, Phone: +81 (0) 3-5316-5020, FAX: +81 (0) 3-5316-5031
Singapore 3015A Ubi Rd 1, 05-10, Kampong Ubi Industrial Estate, Singapore 408705, Phone: 65-746-8760, FAX: 65-746-1206
Mexico Av. Parque Chapultepec #66-201, Col. El Parque Edo. Mex. 53390, Phone: (52) 5358-5434, FAX: (52) 5358-5588
UK 4, The Willows Centre, Willow Lane, Mitcham, Surrey CR4 4NX, UK, Phone: 44 181 640 9600, FAX: 44 181 646 7084
Africa, Mid-East 12000 Portland Ave South, Burnsville, MN 55337, Phone: 952-887-7424, FAX: 952-887-9212
Latin America 12000 Portland Ave South, Burnsville, MN 55337, Phone: 952-887-7491, FAX: 952-887-9212

www.electrovoice.com • Telex Communications, Inc. • www.telex.com

© Telex Communications, Inc. 02/2001
Part Number 38109-964 Rev A



Electro-Voice®

U.S.A. and Canada only.

For customer orders, contact the Customer Service department at
800/392-3497 Fax: 800/955-6831

For warranty repair or service information, contact the Service
Repair department at 800/685-2606

For technical assistance, contact Technical Support at 866/78AUDIO

Please refer to the Engineering Data Sheet for warranty information.

Specifications subject to change without notice.