

ELECTRO-VOICE

BUCHANAN, MI USA

INSTRUCTION MANUAL
for the
MODEL 2509
AUTOMATIC MICROPHONE
MIXER

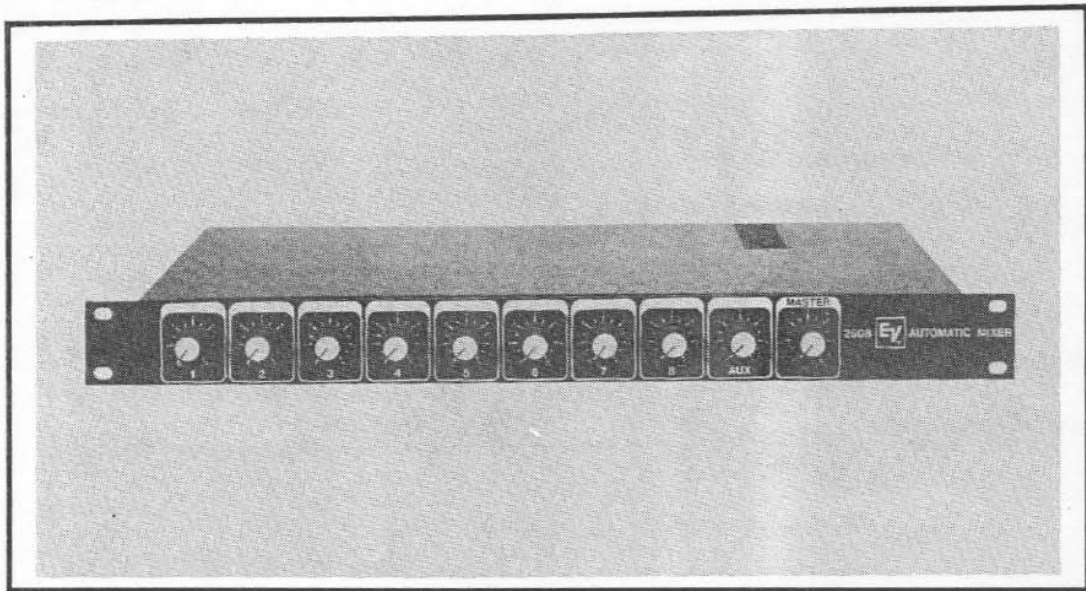

INTRODUCTION

The 2509 automatic mixer is designed to fulfill a number of applications, such as meeting rooms, churches, auditoriums. The 2509 provides all of the standard automatic mixer functions; automatic microphone gating, Number of Open Microphone attenuation, Channel active indication, etc. The 2509 goes far beyond the normal automatic mixer by offering features that greatly enhance its power. Features such as room combining, special paging input, special background music input and remote controls.

The 2509 may be used independently, as an eight-input, one-output mixer, or it may be combined with other EV automatic mixers to create a single 12...16...24...32...64..... input microphone mixer. The 2509 mixer is designed specifically to facilitate room combining applications.

For example, six 2509 mixers can be configured so that the six separate mixers are feeding six separate rooms. Or they could be configured as one 48 input automatic mixer. The six separate mixers could also be wired so they could be combined together via remote switches. These switches could be remoted to a control panel that would then determine which mixers/rooms would be combined. This would allow for various mixer/room combinations.

EIGHT AUTOMATIC MIC/LINE INPUTS

The 2509 automatic microphone mixer has eight automatic, electronically balanced, microphone/line inputs. These eight inputs contribute to a threshold comparison circuit to determine which input will be gated on. Also, each input contributes to and is affected by the NOM (number of open microphones) attenuator. When an input is used as a line input, the contribution to the NOM of that channel, may be disabled. In addition, there are three non-automatic line level inputs.

NON-AUTOMATIC LINE INPUTS

Input number nine is an unbalanced line input with front panel or remote volume control. This input can provide mixing from an auxiliary line level source such as a projector, tape recorder etc. Neither this input, or the other two line inputs, affect the NOM attenuator or threshold circuits. Inputs ten and eleven are also line level and unbalanced, but have no front panel volume control. They are designed with the specific application of background music and paging in mind.

Both line inputs have a 50,000 ohm input impedance to allow the paralleling of inputs with other mixers. Over 80 mixer inputs may be driven from a single 600 ohm source. Both inputs may be individually muted, via remote DC control lines. This means that the background music on/off function may be remoted to the meeting room. The level of the music may be controlled by the remote master volume control.

The paging input is designed with normal "page over" the program material, or it may completely mute the program material during the page. Also, with the addition of an external 10k linear potentiometer the program material may be "ducked" during the page.

The paging features of the 2509 greatly simplify the design and installation of systems utilizing paging and background music. This is especially true with emergency page applications.

REMOTE CONTROLS

The 2509 has many standard remote control features. These control features provide many benefits in solving design applications. All remotes are via low voltage DC control lines. The MASTER, AUX and the eight mic/line volume controls may be remoted to a standard 10k linear taper potentiometer. Also the eight mic/line channels may be remotely turned on and off. The three line inputs may also be remotely turned on and off.

***** FRONT PANEL CONTROLS *****

INPUT LEVEL CONTROL

There are nine input level controls on the 2509. The first eight control the input level from the eight MIC/LINE channels and are labeled "1", "2", "3" through "8". The ninth control is for the AUX (AUXILIARY) input and is labeled "AUX." These nine controls provide the normal function associated with an input level or volume control. These ten inputs may also be remotely controlled.

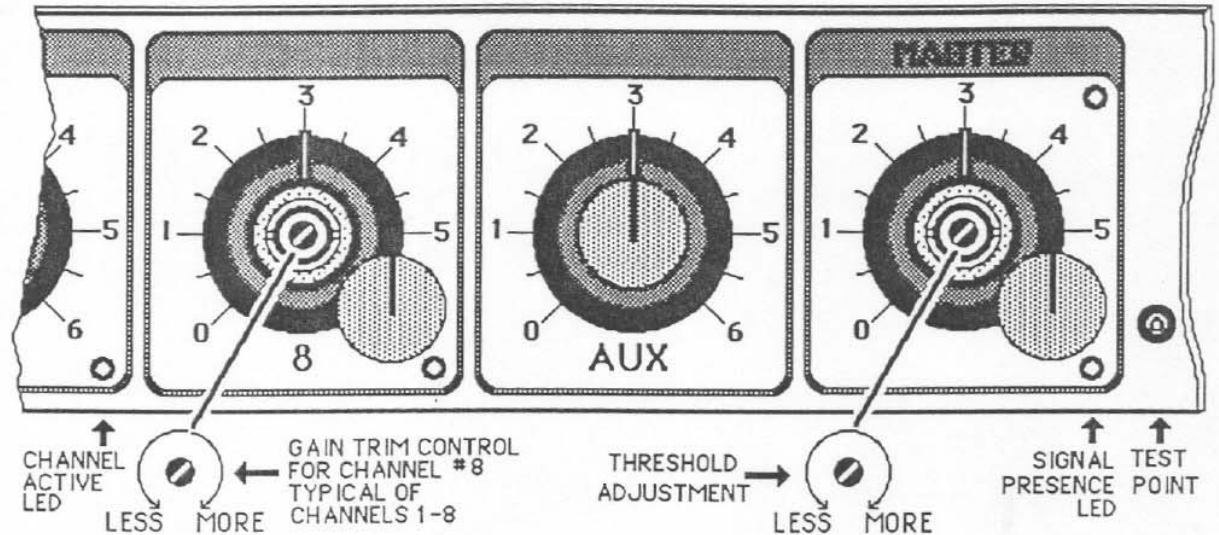

GT (GAIN TRIM)

There are eight GAIN TRIM controls located on the front panel. These are screwdriver adjustable shafts located behind the knob cap of each volume control. This cap must be removed to access the GAIN TRIM control. Rotating the GT control in a clock-wise direction increases the gain through the preamplifier.

The GAIN TRIM control sets the maximum gain through the individual mic/line channel. It also maximizes the signal to noise ratio and the input overload characteristics of the preamplifier. When properly adjusted, this control can help prevent feedback due to operator error. This is accomplished by adjusting the GAIN TRIM control to a level that is just below feedback with the VOLUME control set at maximum.

The GAIN TRIM control is used in conjunction with the 20 dB pad switch in the preamplifier. The GAIN TRIM control should be adjusted **before** the 20 dB pad is used. In other words, attenuation of a high level signal should be accomplished by turning the GAIN TRIM control counter-clockwise. If the signal requires additional attenuation, then the 20 dB pad should be employed. Of course if line level signals are being fed to the preamplifier, the mic/line switch should be set to the line position.

The GAIN TRIM setting also has an affect on the automatic gating sensitivity of the individual microphone channel. The GAIN TRIM control is provided to allow adjustment of the channel gain to compensate for differences in sensitivity of different microphone types. This allows all of the channels gains to be normalized.

An individual microphone may have its gating sensitivity increased above the norm by turning up the GAIN TRIM control for that channel. In the same manner a microphone can have its gating sensitivity reduced by turning the GAIN TRIM control for that channel down. Differences in normalized gain will of course need to be compensated for by the setting of the channel volume control.

TONE CONTROLS

Channels one and two have adjustable bass and treble tone controls. These controls are located on the front panel adjacent to the channel volume controls. The controls are located on the front panel so that they may be set by the installer. However, once set, these controls should not be adjusted by end user. To do so could affect the gain before feedback threshold of the system.

An effort has been made to disguise these controls. It is hoped that the controls will have the appearance of flat-head hex screws. There are no markings on the front panel to indicate that these "flat-head screws" are controls. A 5/64 allen wrench is required to make adjustments to the tone controls.

A small indentation or slot on the front of each control is the only indication of the controls setting. When the slot is set to an imaginary 12 o'clock position, the tone control will provide neither boost or cut to the input of that channel. Rotating the control clockwise will boost the level at the frequency of the tone control. Rotating the control counter-clockwise will decrease or cut the level at the frequency of the tone control. The tone control has a mechanical rotation of 270 degrees, much like a standard volume control.

The bass tone control can provide a maximum of 12 dB boost or cut at approximately 30 hertz with a knee at 1kHz. The treble tone control can provide a maximum of 12 dB boost or cut at approximately 10 kHz with a knee at 1 kHz.

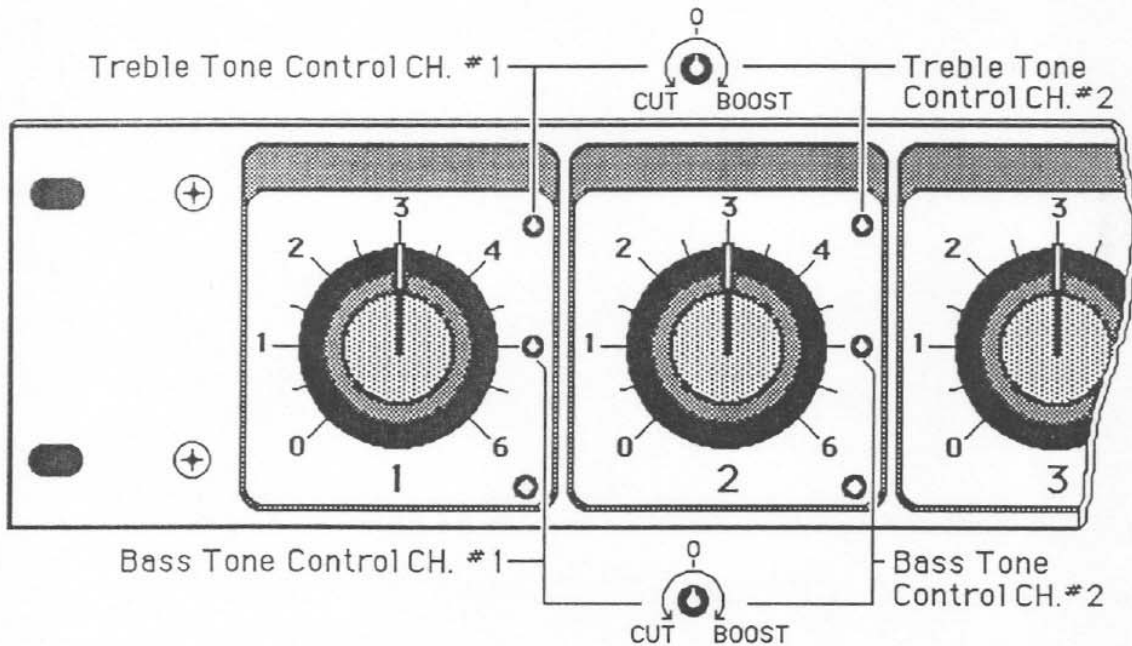

CHANNEL ACTIVE LED

In any automatic mixer it is desirable to provide a front panel indication of channel gating status. This gating status displays which microphones are currently on and which microphones are currently off. This type of indication is of great benefit when installing and setting up the mixer.

The status indicators help determine the proper placement of microphones relative to the desired source. Tests may be run using microphones of various polar patterns while monitoring the gating status to determine which microphone is best for a particular application and environment. Monitoring the gating status is also beneficial while setting the THRESHOLD level.

The 2509 has eight LEDs that provide gating status. There is one Yellow LED for each of the eight automatic mic/line inputs. This LED is located in the lower right hand corner of each channel's label area and illuminated whenever the channel is gated on by the automixer.

The Channel Active or Logic Output for each channel (located on the rear panel) is activated whenever the LED channel status indicator is illuminated. See the "Channel Active Output" section of this manual for more details.

THRESHOLD

The THRESHOLD control is concentric with the Master Level control located on the front panel. The THRESHOLD control is a slotted shaft located behind the knob cap on the Master level control. This cap must be removed to access the THRESHOLD control. After adjustment of this control the cap should be replaced.

The heart of any automatic mixer is the circuit that determines which microphones should be gated on and which microphones should remain off. The 2509 accomplishes this task by comparing the input level of each individual microphone to the sum of all the microphone inputs. A portion of the sum of all the inputs creates the dynamic THRESHOLD sense buss. In order for a microphone to be gated on, its input level must exceed the level of this THRESHOLD sense buss by a certain number of dB. The THRESHOLD control sets the number of dB that the individual channel must exceed the dynamic THRESHOLD buss in order to be gated on. If the THRESHOLD control is set for +8 dB, then the signal level from a microphone must exceed the dynamic THRESHOLD buss by 8 dB before it will be gated on.

As you can see, the THRESHOLD control determines how easily the microphones will gate on. If this control is set too low, then ambient noise in the room may cause the microphones to gate on and off in a random manner. If the control is set too high, then the individual microphones may fail to gate on when spoken into by a soft-spoken person. This control is best set during actual operating conditions.

In the actual operating environment with the microphones connected to the mixer, turn the THRESHOLD control fully counter clock-wise to start the adjustment procedure. The microphones should gate on at very low level sound pressure levels. Depending upon the ambient noise level in the room the microphones may gate on and off in a random matter. This is normal. Now, turn the THRESHOLD control clockwise until the random gating stops under normal ambient noise conditions.

Talk to each microphone to determine the relative level required to gate on the microphone. Adjust the THRESHOLD control to increase or decrease the sensitivity as desired. Turning the THRESHOLD control in a clock-wise direction increases the THRESHOLD level requiring a greater level at the microphone to gate on.

The THRESHOLD control affects all eight channels equally. When used in combinations with other mixers each 2509 is affected only by its own THRESHOLD control although all of the THRESHOLD buses are mixed together. This provides independent zone control for each mixer.

MASTER LEVEL CONTROL

The MASTER LEVEL control affects the level of all channels at the same time. The mix of all the channels is maintained as the master level is varied. When multiple automixers are combined there are two options available in remote master control. With option number one only the MASTER LEVEL control on the first mixer is active and controls the level for all other mixers as well. The MASTER LEVEL controls on all other mixers are disabled.

With option number two, all mixers retain their own independent MASTER LEVEL control. This option is determined at the time of installation and is selected on the optional 25ACC active combining card.

SIGNAL PRESENCE LED

The yellow LED located below the MASTER LEVEL control is the output signal presence LED. It is connected to the output of the 2509 and flashes when an output signal is present. The brilliance of the LED is modulated by amplitude of the output signal. This LED is very useful in visualizing the signal flow through the system.

TEST POINT

The test point is located to the right of the MASTER LEVEL control on the front panel. The test point is connected to the output of the 2509 via a 600 ohm resistor. This test point allows the use of oscilloscopes, real time analyzers, voltmeters, etc., for system documentation and trouble shooting. The 600 ohm isolation resistor will not affect the accuracy of the measurement when the test instrument input impedance is greater than 50,000 ohms. The output signal is referenced to the chassis ground.

***** INTERNAL CONTROLS and CONNECTIONS *****

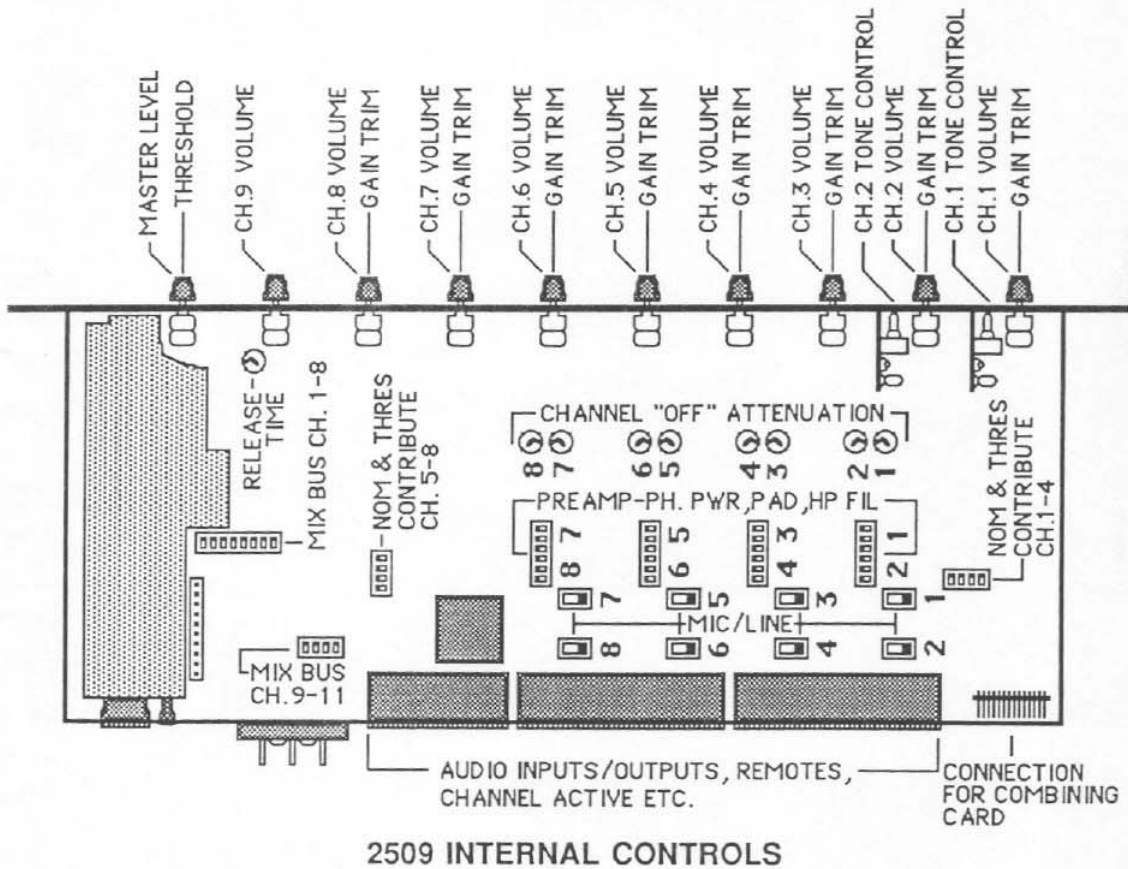

MIX BUSS ASSIGN

There are two mix buss switches inside the 2509. An eight position dip switch handles inputs 1-8. A four position dip switch handles inputs 9-11.

When a switch for an individual channel is set to the ON position, that channel contributes audio to the output of the mixer. If the switch is set to the off position then the audio from that channel is isolated from the output of the mixer. Any channel may be isolated from the MIX BUSS by setting the individual switch for that channel to the OFF position. This is useful when a channel is to be used as an independent preamp.

Channel number 11 has two assign switches to provide several options when the paging feature is used. Please refer to the "PAGE" section of this manual for information on these options. The two switch positions for this channel are labeled "PAGE" and "EM PAGE."

OFF ATN (OFF ATTENUATION)

When the automixer gates a channel off, the output of that channel can be attenuated by up to 90db. When the output of the 2509 is used to drive ancillary areas, such as foyers, it is highly desirable to only reduce the level of the program material to the foyer and not to turn it completely off. The audio feed to these ancillary areas contains the program material plus the noise of the meeting room. It is the total and abrupt discontinuance of the room noise that is objectionable to the people listening in the foyers.

The OFF ATN feature allows the output level from the microphone to be reduced, thus maintaining the gain before feedback margin without totally interrupting the feed to the ancillary areas. The OFF ATN for all channels is factory set at approx. 18 dB. This will explain why even though the front panel Channel Active LEDs indicates that the channel is OFF, that audio can still be heard through the mixer. The amount of off attenuation is adjustable from -3 dB to -90dB.

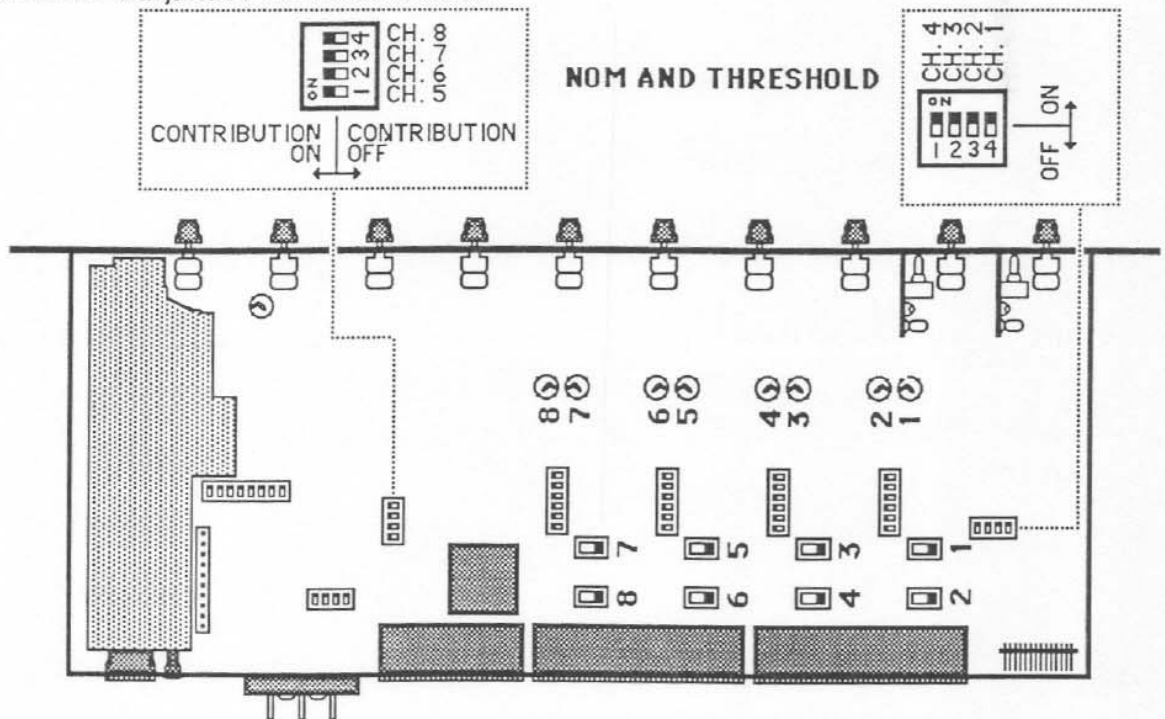

NOM and THRESHOLD CONTRIBUTE

Channels 1-8 all contribute to NOM (number of open microphones) buss and to the THRESHOLD buss for

gating comparisons. Not all audio signals input to the mixer should be allowed to affect the NOM and THRESHOLD busses. A line input will drive up the threshold level and make it more difficult for a microphone to gate on. The line input will affect the NOM and cause attenuation that is not necessary to maintain the gain level to prevent feedback. The NOM and THRESHOLD CONTRIBUTE switch allows you to disable a channel's contribution to these two busses.

In normal operation, channels 1-8 all contribute to the NOM and the THRESHOLD buss. Whenever any of inputs 1-8 are used for a line input, then that channel should have its NOM and THRESHOLD contribute switch set to the OFF position.

LAST ON

The 2509 has unique circuit that enhances automatic microphone mixing in most applications. When the LAST ON feature of the 2509 is activated there is at least one microphone gated on at all times. **The last microphone that was gated on remains on until another microphone is gated on to take its place.** There is always an open microphone in the room. The LAST ON feature will allow more than one microphone to be on at a time. If in "normal" automatic mixer operation, two mics would be gated ON, then the same is true in the LAST ON mode. The two would then gate OFF when another mic or mics are gated on.

The release timer for the individual channels still works in the LAST ON mode. When a mic is already on and a second mic gates on, the first mic will gate off after the RT timer elapses. The RT timer could be set to a very short time duration. This would allow the first mic to gate off as soon as the second mic gates on.

The LAST ON feature is normally OFF and is enabled by connecting the LAST ON terminal to GND on the rear panel connector.

RT (RELEASE TIME)

The purpose of a RELEASE TIME control on an automixer is to provide smoother operation of the automatic mixing function. If a channel immediately gated off whenever its input level fell below the threshold level, it would be very distracting. It would gate off between syllables, and in some cases, even during a syllable.

The addition of a release timer keeps the channel gated on for a period of time after the threshold circuit tells the channel to gate off. In other words, when a channel receives a command to gate off, it does not gate off immediately, but is held on for a period of time determined by the RT control setting. This is true for both normal and LAST ON automatic operation.

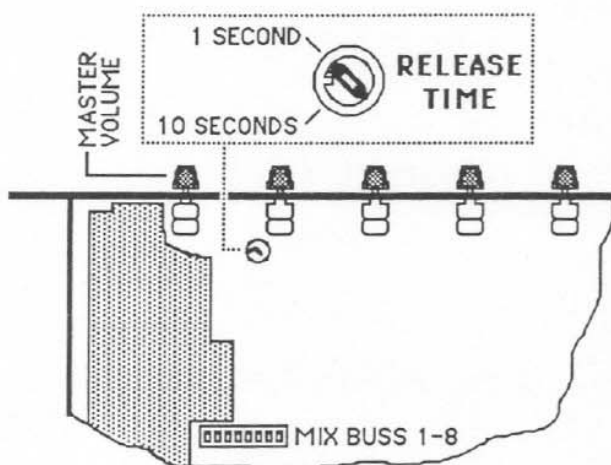

The RT is set for 2-3 seconds at the factory, but may be set in the field to suit the particular application. This setting is proper for 90% of all applications.

The release time is adjustable over a range from 1 second (full ccw) to 10 seconds (full cw). The release time can be set for each individual mixer application. As a rule of thumb, the RT should be set so that the channel remains on during pauses in normal speech.

The RT control is located inside the mixer on the printed circuit board behind the AUX level control. (See 2509 INTERNAL CONTROLS illustration) It is labeled **RELEASE TIME**. This screwdriver adjustable potentiometer controls all eight channels. When automixers are combined, the RT controls remain independent. The RT circuit remains active when the LAST ON feature is used. Refer to the LAST ON section of this manual for more information.

***** INPUTS AND OUTPUTS *****

MIC/LINE INPUTS (CHANNELS 1-8)

These eight inputs are electronically balanced. In the MIC setting, the input impedance is approximately 10,000 ohms and is designed to work with low impedance microphones (150-600 ohms). The mixer has in excess of 76dB of gain and will accommodate the most insensitive microphone. A switchable 20dB pad allows the input to accept the higher output levels of condenser microphones.

Each input channel has three outputs. There is a PRE-GATE output, a POST-GATE output, and an output to the mix buss of the mixer. The first two outputs will be discussed elsewhere in this manual. The output of each channel is routed to the mixbuss through a switch on the printed circuit board. Normally this switch would be closed to route the signal to the mix buss. In some applications it is necessary to have a microphone preamplifier whose output is routed elsewhere. The PRE or POST-GATE output would then be used and the mix buss switch would be opened to isolate that channel from the mixer. See the "CHANNEL OUTPUTS" manual section for more information. Phantom power is available for condenser microphones and is applied individually to each input. For more information about phantom power refer to the section of this manual titled "PHANTOM POWER."

In the LINE setting, a balanced 40dB resistive pad is inserted in the circuit. The impedance of the LINE input is 20,000 ohms. The line input can accept levels in excess of +28 dBm.

All eight inputs can be remotely turned on and off. The manual section titled "REMOTE ON/OFF CONTROLS CHANNELS 1-8" contains detailed information on this feature.

AUX INPUT(AUXILIARY, CHANNEL 9)

The AUX input may be controlled from either the front panel or via remote control. The AUX input is an unbalanced line level input. The input impedance is 50,000 ohms. A 0.5 volt rms signal will drive mixer output to +18 dBm. The input can accept a level of +18 dBm before distortion.

The AUX audio input may be remotely turned on and off. **The AUX input is normally off and can be turned on by connecting the CH.9 Channel Remote ON/OFF terminal to the +10V terminal on the rear panel connectors.**

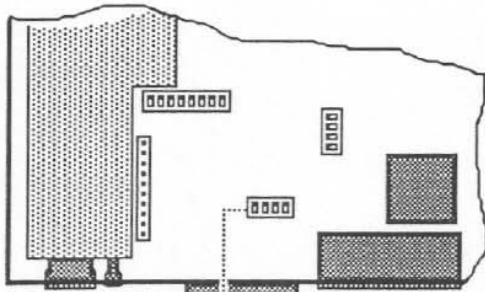

PLEASE NOTE!: There are two mix bus assign switches for channel 11. Both switches are for the page input. The PAGE switch (#3) allows the page audio to mix with the program audio. The EMERGENCY PAGE switch (#4) is used in conjunction with Page Override function of the mixer. This mutes the program audio and allows only the page audio to be heard. Please refer to "PAGE" section of this manual.

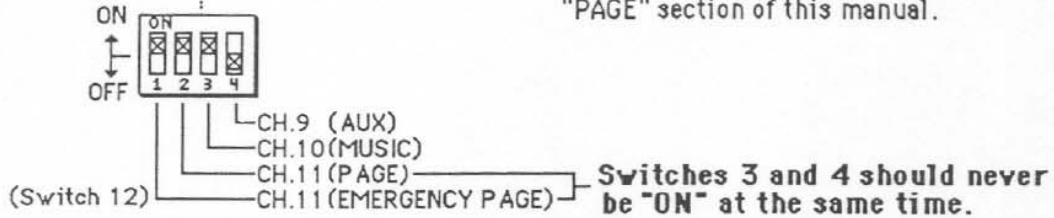

BUSS ASSIGN SWITCH FOR CHANNELS 9, 10, 11

BACKGROUND MUSIC INPUT (CHANNEL 10)

The 2509 has a special input for background music. Of course, use of this input is not restricted to background music applications. This channel can be isolated from the mix buss by opening its mix buss assign switch. This input is different from inputs 1-9 in that it has neither a front panel or internal volume control. This input is normally off unless specifically turned on by connecting the CH.10, Channel Remote ON/OFF terminal to the +10 volt terminal on the rear panel connectors.

There are two mix buss switches inside the 2509. One switch has eight switch positions for channels 1-8. The other switch has four switch positions for channels 9,10, and 11. The four position switch is located adjacent to the output transformer.

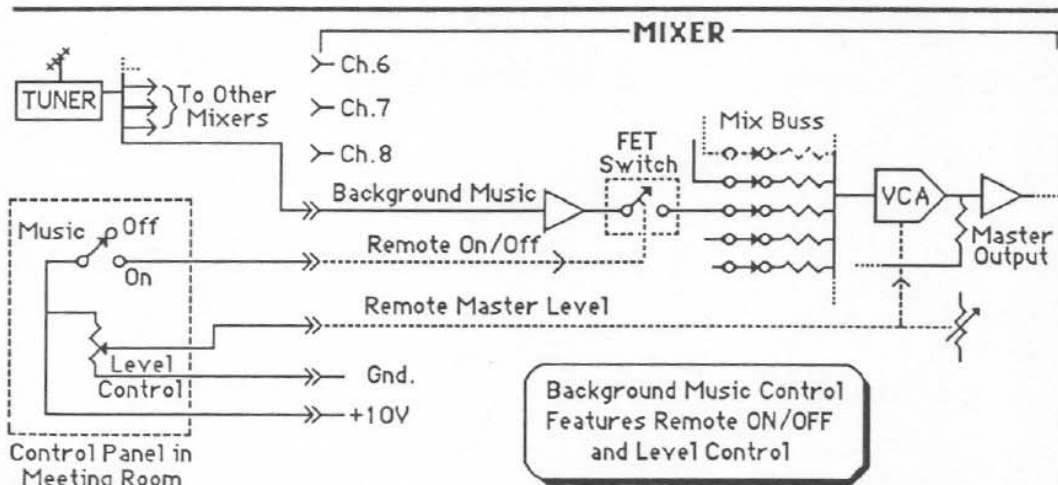

TYPICAL BACKGROUND MUSIC APPLICATION

This input is fixed in gain with a sensitivity of 0.5 volts RMS in for 0.775 volts (0dBm) out. The maximum input level is +18 dBm. The input impedance is 50,000 ohms. This high input impedance facilitates the paralleling of BACKGROUND MUSIC inputs between a large number of mixers. Over 80 separate inputs can be driven from a single 600 ohm source.

The fixed gain requires that the background music source have a variable gain stage to set the level. Setting the maximum permissible level for one mixer in a group sets it for all mixers in that group. The level out of the mixer may be controlled from remote location, such as a meeting room, via the remote master volume control. The background music feed to the meeting room may be muted entirely via the remote on/off feature on this input.

The BACKGROUND MUSIC input has a FET switch in series which allows the input signal to be turned on or off from a remote location. This switch is normally off thus, muting the background music. The illustration below shows a typical application of this input used in conjunction with a remote master volume control.

PAGING INPUT (Channel 11)

If you have not yet done so, read the "BACKGROUND MUSIC INPUT" section of this manual before continuing. The paging input is identical to the BACKGROUND MUSIC input but with one addition. The addition is that the PAGING INPUT has two mix buss assign switches.

Mix buss assign switch 11 connects the PAGE audio to the same audio summing point as all the other inputs. This is the standard mix buss whose output is then fed to the VCA. The VCA will affect the page audio. This means that its level will be affected by the MASTER VOLUME control and the VCA OVERRIDE.

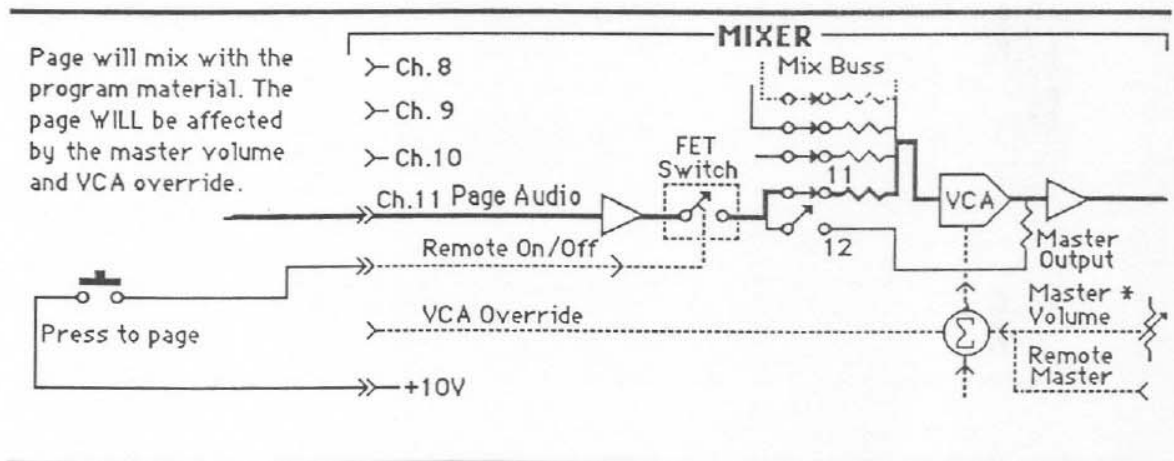

NORMAL PAGE APPLICATION

Mix buss assign switch 12 connects the PAGE audio to a summing point that is *after* the VCA and just before output of the mixer. There are two audio signals fed to this summing or mixing point. One is from the PAGE input #11 and the other is the composite audio from the mix buss via the VCA. When Mix Buss assign switch #12 is "ON", the audio from the PAGE input is **not** affected by the MASTER volume control or the VCA OVERRIDE. This means that a PAGE would go through the mixer to its output despite the MASTER volume control being turned all the way down or the VCA OVERRIDE being activated.

This is ideal for EMERGENCY PAGE APPLICATIONS. The illustration below shows the rear panel connections for this type of application. Also refer to the "VCA OVERRIDE" section of this manual for information on "ducking" program audio during a page instead of complete muting.

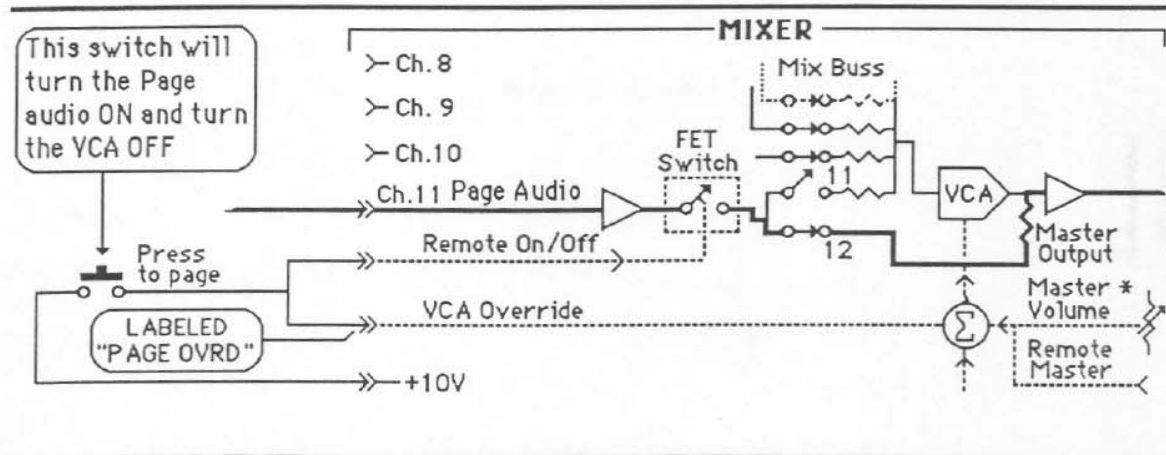

EMERGENCY PAGE APPLICATION

***** CHANNEL OUTPUTS *****

PRE-GATE OUTPUT

The PRE-GATE OUTPUT is a direct output from each channel before it goes through the FET gate circuitry. This output has a maximum gain of 62 dB when referenced to the input level. The actual amount of gain is determined by the settings of the pad and the GAIN TRIM control.

The PRE-GATE outputs are not affected by the gating action of the mixer, the NOM, the channel level control, or the master level controls. It is an ideal feed for a logging recorder when used in a courtroom system. The output is fed through a 604 ohm resistor which allows several PRE-GATE outputs to be tied together at the terminal block. This would mix the outputs together and cause a 6 dB drop in overall output level of the combined PRE-GATE outputs. This is common when two outputs of equal impedance are combined. An additional 6 dB drop will occur every time the number of outputs tied together is doubled.

If the PRE-GATE outputs of all four channels are to be tied together, then it is preferable to use the PRE-GATE mix output of the 2509. This output does not suffer from the reduction in level due to combining because the channels are actively combined. This output can serve as a tape output.

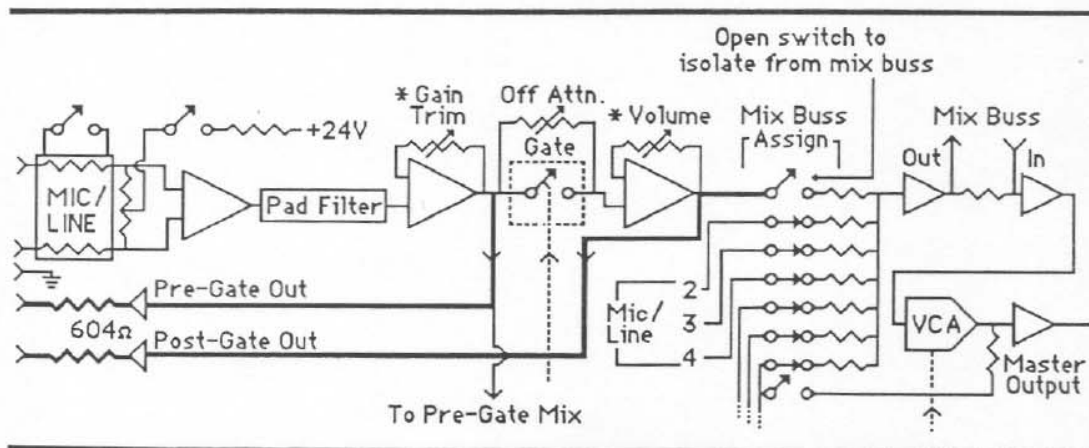

PRE and POST-GATE OUTPUTS

PRE-GATE MIX OUTPUT (TAPE OUTPUT)

The PRE-GATE mix output is a mix of all eight channel's PRE-GATE outputs and the AUX input. The eight channels are mixed together internally and then buffered through an output amplifier. The mix output appears on a terminal labeled "PRE-MIX" on the rear panel connector of the 2509. This output is typically used to feed tape recorders.

When 2509s are combined, the PRE-GATE mix outputs of the individual mixers are NOT automatically combined. If several mixers are being ganged together to create one large multiple input mixer, then you may wish to tie the PRE-GATE mix outputs together. This is accomplished by directly connecting the mix outputs together from terminal labeled "PRE - MIX" of one 2509 to the "PRE-MIX" terminal of the next 2509, and so on. A 6 dB drop in overall level will occur when the two "PRE-MIX" outputs are connected together, and an additional 6 dB drop will occur every time the number of mix outputs connected together is doubled (1-2-4-8.....).

POST-GATE OUTPUT

This signal will only contain information from the individual channel. It will, however, be affected by the pad filter, gain trim, and all normal functions associated with that channel, such as AUTO GATING, REMOTE CHANNEL ON/OFF, OFF ATTN, and FRONT PANEL LEVEL control. The impedance of this output is 60 Ohms. This allows it to be mixed with other outputs if desired. The Post-Gate outputs appear on the rear panel connector labeled "POST-GATE OUTPUT".

In addition, the audio of any channel may be isolated from the rest of the mixer by setting the MIX BUS ASSIGN switch to OFF position. The POST-GATE OUTPUT from that channel would then be the main OUTPUT for that channel. When the audio of any channel is isolated from the mix buss, it is normally desirable to isolate the logic functions associated with that channel. This is accomplished by setting the NOISE and THRESHOLD CONTRIBUTE switch to the off position for that channel.

******* PREAMP CONTROLS *******

MICROPHONE/LINE INPUT SWITCH

Each input may be switched to accept either microphone or line levels. Note: When using mic or line level signals from outside of the closed loop of the sound system, you may wish to consider disabling the contribution of that channel to the NOM and THRESHOLD circuitry. This is easily accomplished by setting switch on the mixer printed circuit board. Refer to the NOM/THRESHOLD SWITCH section of this manual.

20 dB PAD

The 20 dB pad may be used to normalize microphone inputs when dynamics and condensers are used. The 20 dB pad should be switched in only after the GAIN TRIM control has been turned fully counter-clockwise and more attenuation is required.

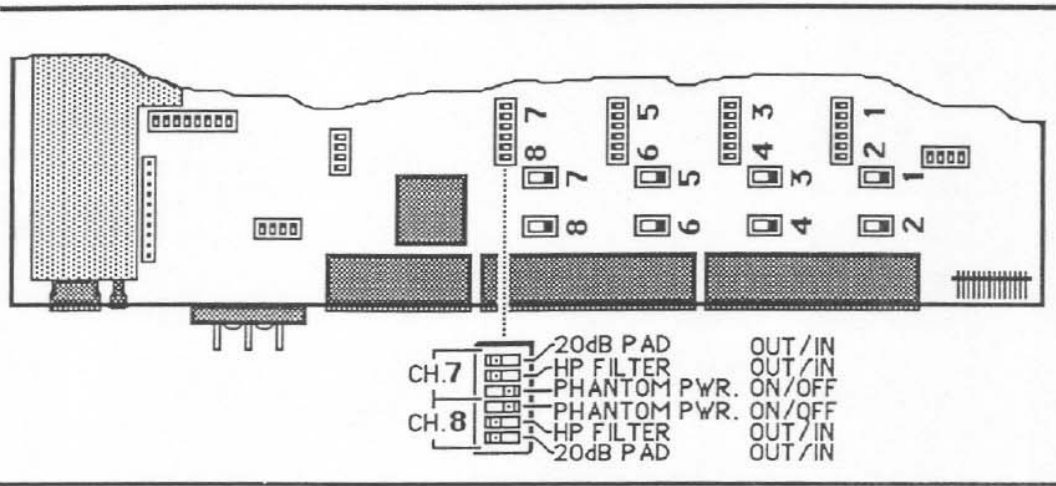

PREAMPLIFIER CONTROLS

HIGH PASS FILTER

The high pass filters in the 2509 are unique. Unlike the majority of other mixers that provide a high pass filter with a 6 dB/octave rolloff that starts at 250Hz, the 2509 HP filter has a rolloff slope of 30 dB/octave and is 6 dB down at 125Hz.

This provides several advantages. The 6 dB down point of 125Hz does not affect the quality of human speech. This filter response eliminates the most annoying part of P-Pops and other plosive sounds generated when speaking into a microphone. It also minimizes low frequency noise that is typically generated when handling a microphone.

PHANTOM POWER

Phantom power for condenser microphones is available on each of the four MIC/LINE inputs. The internal power supply provides 24Vdc and is connected to the input through a pair of 3,400 ohm resistors. This supply will also work with condenser microphones requiring lower voltage and higher current, provided the microphone contains its own internal voltage regulator. The phantom power is turned on to each input by setting the appropriate dip switch to the ON position.

***** **REMOTE CONTROLS** *****

REMOTE ON/OFF CONTROL CHANNELS 1-8

Channels 1-8 have two modes of operation; automatic gating ON and OFF, manual ON and manual OFF. The automatic gating mode should be considered the normal mode of operation. Automatic gating of the microphones is dictated by microphone usage. This automatic mode of operation may be overridden by the use of remote ON/OFF controls.

The capability of remotely turning a channel on or off is provided on the 2509. The remote function will override the automatic gating function of the mixer. For example: Channel number 1 has been gated ON by the mixer due to a person speaking into that microphone. Channel number 1 may be turned OFF, via the remote ON/OFF function, even as the person continues to speak. The converse is also true. A microphone that is gated OFF may be turned ON via the remote ON/OFF function. The remote ON/OFF function has precedence over the automatic gating function.

Remember, that when a channel is gated OFF it will not necessarily be completely OFF. It will only be OFF by the level set by the OFF ATTN.

Connections are made to the rear panel connectors labeled "Remote Channel ON/OFF". Connecting remote terminal to ground will turn that channel OFF. Connecting the terminal to +10Vdc (supplied by the 2509) will turn the channel ON. The illustrations below provide some ideas on remote on/off control.

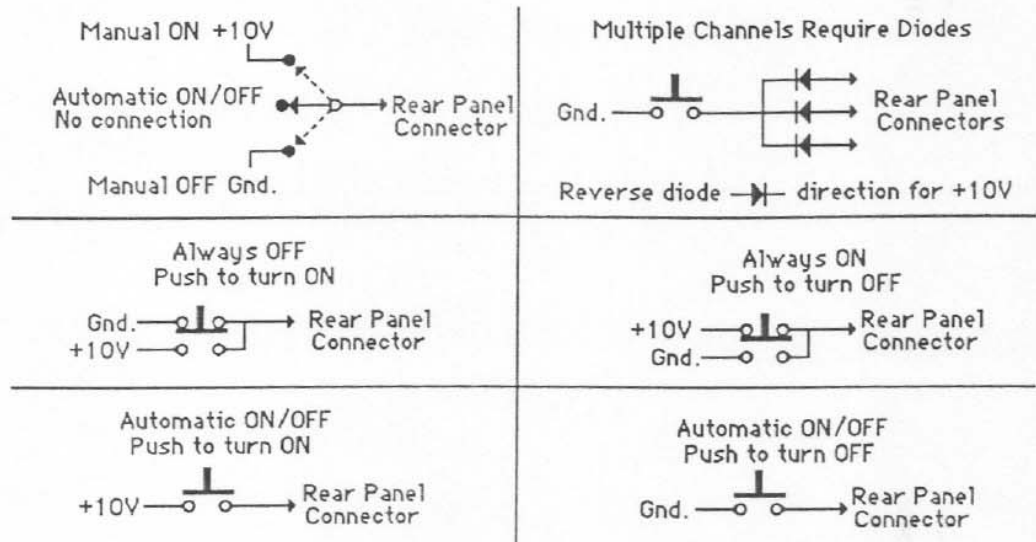

REMOTE ON/OFF CONTROLS FOR CHANNELS 1-8

The +10Vdc and Gnd. reference can be obtained from the rear panel connectors. These are the same connections used by the remote volume control(s).

REMOTE ON/OFF CONTROL OF CHANNELS 9-11

The remote control of channels 9-11 differ from channels 1-8 in that there is no automatic mode to override. Channels 9-11 are normally turned OFF and must be connected to +10Vdc to be turned ON. This may seem a bit odd until it is realized that it is in keeping with the logic applied to the other channels. **Channels 9-11 are normally OFF and must be turned ON via the remote control connections.**

The rear panel connections are labeled "Channel Remote ON/OFF", CH.9, CH.10, CH.11. The illustrations below provide some ideas on remote on/off control.

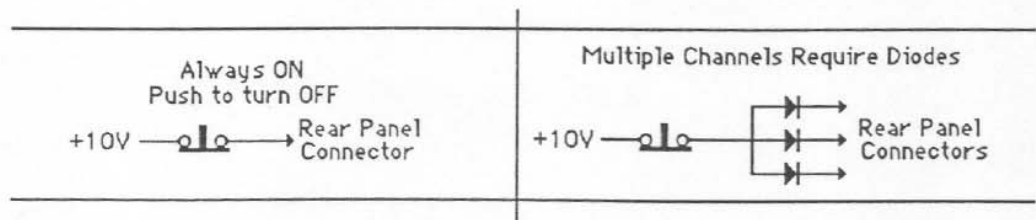

REMOTE ON/OFF CONTROL FOR CHANNELS 9-11

MASTER REMOTE LEVEL CONTROL

The MASTER LEVEL control may be remotely controlled. All remote controls are activated by safe, low-level dc voltages. The remote control has been designed with simplicity in mind. Custom remote controls can easily be designed and constructed by the installer. The volume control has a 90dB range. The control voltage varies from 0 to +10 vdc and is supplied by the 2509. With 0 vdc at the remote terminal, the channel is at full output (0 dB attenuation). The channel is at maximum attenuation (-90dB) when +10 volts is applied to its terminal.

An added feature of the 2509 is the automatic switching between local (front panel control) and remote control. **When a remote control is connected to the mixer, the corresponding front panel control is disabled** and relinquishes control to the remote. When the remote control is unplugged or disconnected, the master level is again determined by the front panel control.

It is evident that the master level control may be preset for certain predetermined operating level. This preset may then be overridden from a remote location simply by connecting the remote control to the mixer. This provides manual control for special events. When the remote is disconnected, the mixer resumes the preset levels.

The figure below shows the simplicity of the remote circuitry. Note that only a 10,000 ohm linear taper pot is required. It is important to note that the switch from remote to local is made **ONLY** when the connection between the pot wiper and the remote terminal is broken. The remote/local switching **CANNOT** be accomplished by disconnecting the +10 volts or control ground.

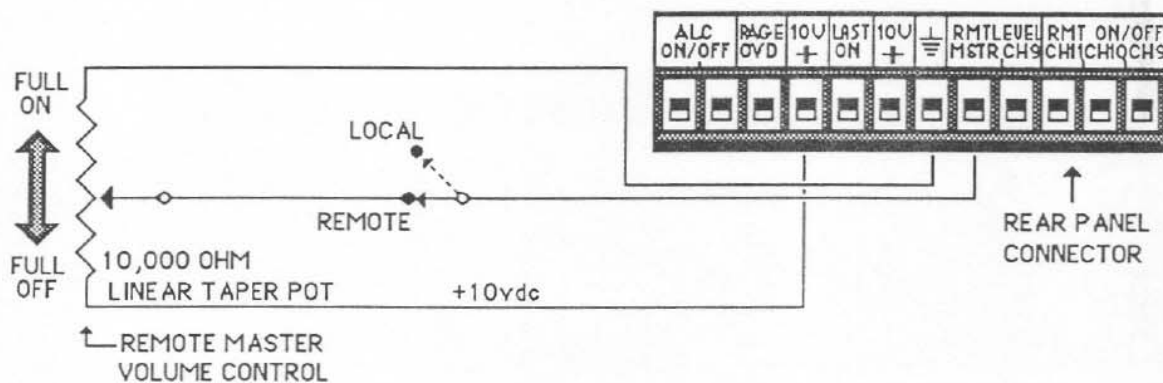

REMOTE MASTER VOLUME CONTROL

REMOTE VOLUME CONTROL FOR CHANNELS 1-9

The eight mic/line inputs and the AUX input may all be remotely controlled. The remote control for these inputs is identical to the remote control for the master. All remotes use a 10K linear taper pot. The pot is connected across the +10V DC and ground. This voltage is supplied by the mixer. The wiper arm of the pot is connected to the remote control terminal for that channel. Please refer to the connection diagram for the remote master volume control.

All remote controls may share the +10V and ground connections. A separate wire for each channel is then used to connect the pot wiper arm to the remote terminal.

VCA OVERRIDE

The VCA Override has the highest priority of all VCA control lines. This is an external control line that appears on the Rear Panel connector labeled "PAGE OVRD" for page override. When this terminal is connected to +10Vdc (supplied by the mixer) the VCA will mute all signals through the VCA regardless of the front panel and remote master control settings. Only signals after the VCA will go to the output of the mixer.

This control is often used in emergency page applications. For emergency page application information refer to the PAGE INPUT section of this manual.

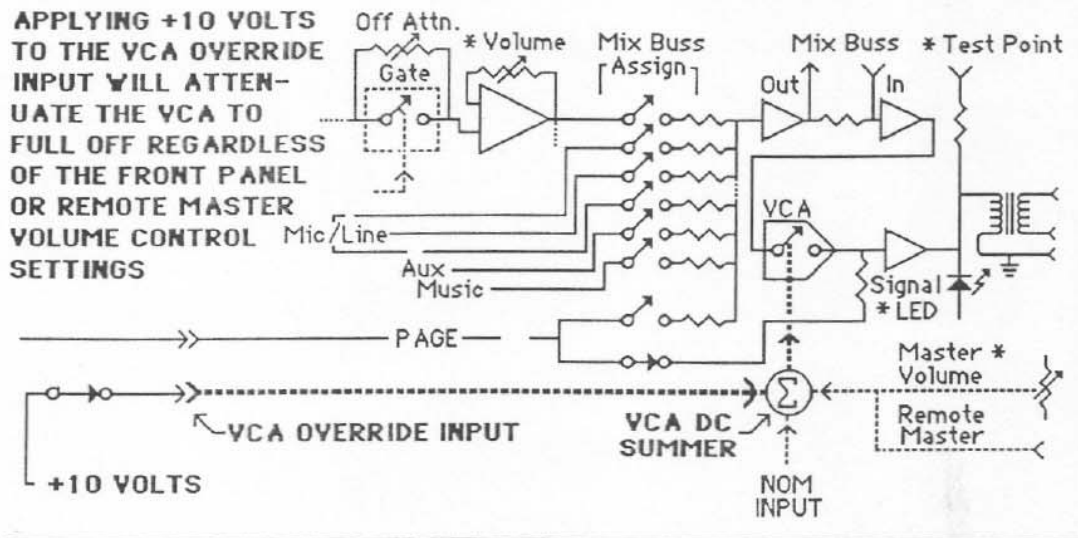

VCA OVERRIDE

The VCA override may also be used to "duck" the signal level through the VCA while paging through the page input with mix buss switch #8 ON. This is accomplished by connecting the "PAGE OVRD" terminal to a voltage less than 10 volts. This will cause the VCA to attenuate proportional to the amount of voltage applied to the terminal. The paging signal that is mixed in after the VCA will remain at a constant level during the page while all signals prior to the VCA will be attenuated. The simple circuit illustrated below shows how to obtain variable voltage for "ducking".

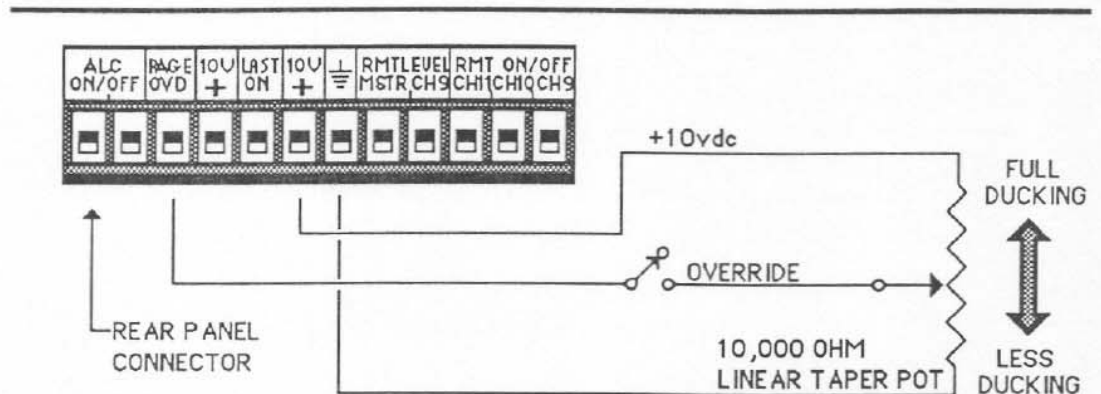

DUCKING CONTROL USING PAGE OVERRIDE

CHANNEL ACTIVE OUTPUTS (Logic Output)

Each of the eight MIC/LINE channels on the 2509 has a CHANNEL ACTIVE output, sometimes referred to as a logic output. This output is designed to interface with external devices, and is of the transistor (MPSA13) open collector type.

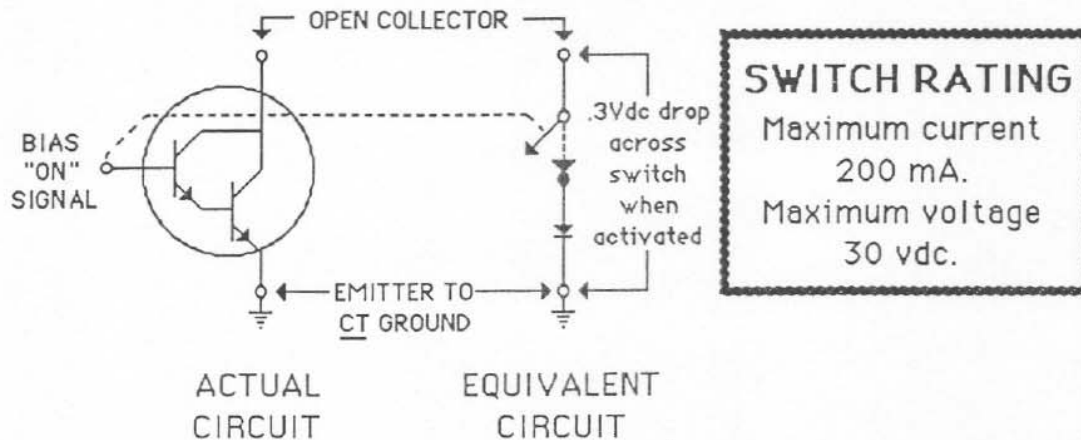

The collector of the transistor is connected to the rear panel connector. The transistor's emitter is connected to ground. Whenever the channel becomes active as indicated by the CHANNEL ACTIVE LED on the front panel, the transistor is turned on and the collector is shorted to the emitter, and thus to ground.

Think of the transistor as a normally open switch that closes to ground when the channel becomes active. As with all switches, there are voltage and current limitations on the contacts. The current through the CHANNEL ACTIVE transistor should be limited to 200 milliamps (.2 amps). The voltage across the transistor should not exceed 30 volts dc.

Power to drive the external device must be supplied by the installer. The device to be powered is connected between the positive side of the external supply and the rear panel connector. The negative side of the external power supply is connected to ground.

If a relay is used as the external device, a diode should be connected across the coil of the relay with the cathode (the end with the band around it) connected to the external power supply side of the coil.

Below is an example of external devices connected to the channel active outputs. As you can see, there are several different methods of remote monitoring. The sonalert is connected via several diodes to different channels. Diodes may be used with other indicators as well.

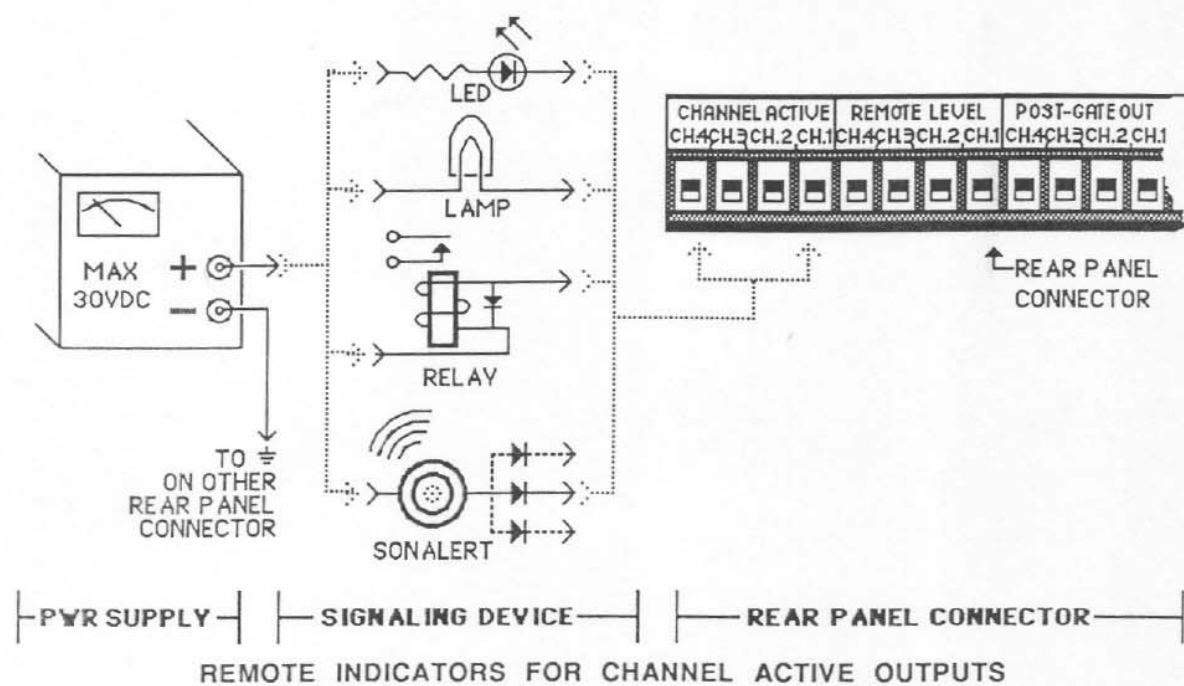

REAR PANEL GROUND-LINK CONNECTION

The wire jumper that connects the two ground-link terminals together **must be left in place** unless the installer is very competent in ground loop trouble shooting and audio grounding practices.

The rear panel ground connections provide access to the "Star Point" ground system of the mixer. The audio and control grounds of the mixer are brought together at one point inside the mixer. The audio and control grounds are then connected to the chassis of the mixer.



The Ground-Link terminals on the rear panel of the mixer are connected to these two points. The audio and control grounds are connected to the chassis through this terminal block. These two terminals must be tied together at some point in the system. The mixer will not operate properly without this connection.

Access to these connections are provided to facilitate the elimination of ground loop related problems in large scale or complex installations. It is beyond the scope of this manual to address system grounding applications.

Should you have specific grounding questions we suggest that you contact the factory.

***** MULTIPLE MIXER OPERATION *****

GANGING MULTIPLE 2509s (or Making One Big Mixer)

Multiple 2509s (or any other 2500 series mixer) may be ganged together to provide an automatic mixer with more than eight automatic inputs. This is done by connecting the desired number of mixers together in series configuration. The mixers are bussed together using **optional accessory** combining cards and plugging them between COMBINE I/O connectors on the rear of the mixer.

There are two different combining accessories for the 2509. One is an **Active Combining Card (25ACC)**, and the other is a **Passive Combining Cable (25PCC)**. Whenever two or more 2509 mixers are to be combined, at least one 25ACC active combining card is required. After an active card is used additional mixers may be combined with the first two mixers using 25PCC passive combining cables. However, when mixers are to be switched in and out of the combining mode to provide a room combining function, an Active card is required for each one of these switching points.

Lets take the example of a single 32 input mixer. This requires that four 2509s be ganged together to provide the 32 inputs. There is no requirement for the 32 input mixer to be combined with additional 2509s or to be separated into 4 individual mixers. This configuration would require the purchase and installation of one (1) 25ACC and two (2) 25PCC combining cables. The 25ACC would be installed between the first and second mixer. The two 25PCC cables would be installed between the second and third and the third and fourth mixers. The combination is made when the COMBINE terminals on the first 2509 are connected together.

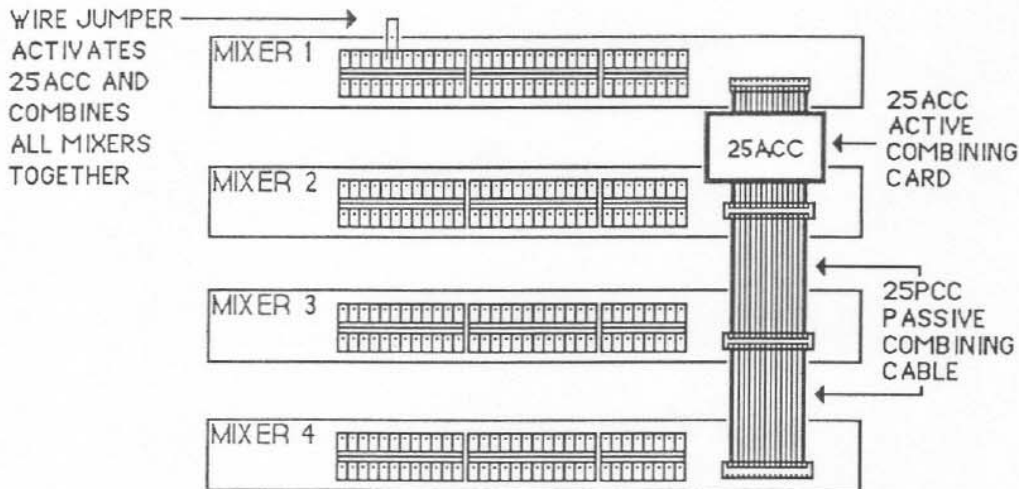

FOUR MIXERS COMBINED TO MAKE ONE THIRTY-TWO INPUT MIXER

This approach to combining allows the cost of the additional circuitry to be borne only when the circuitry will be used. The cost of the Active card is more expensive than the Passive cable.

Let us use the example of four mixers again but in a different configuration. In this example we have two meeting rooms. Each room requires sixteen inputs. There is a movable wall that separates the two rooms. On occasion this wall is opened and the sound systems of the two rooms need to be combined. The COMBINE function of the mixers allows us to perform this operation.

Three (3) 25ACC cards are required. They are utilized as illustrated below. Notice that the COMBINE switch wired to the mixer of the second 25ACC provides the room combining function. This is a low level DC remote control and can be remoted to a convenient location. Additional automixers could be ganged with mixers 3 and 4 using 25PCC cables as long as an ACTIVE card is used between the two groups of ganged mixers.

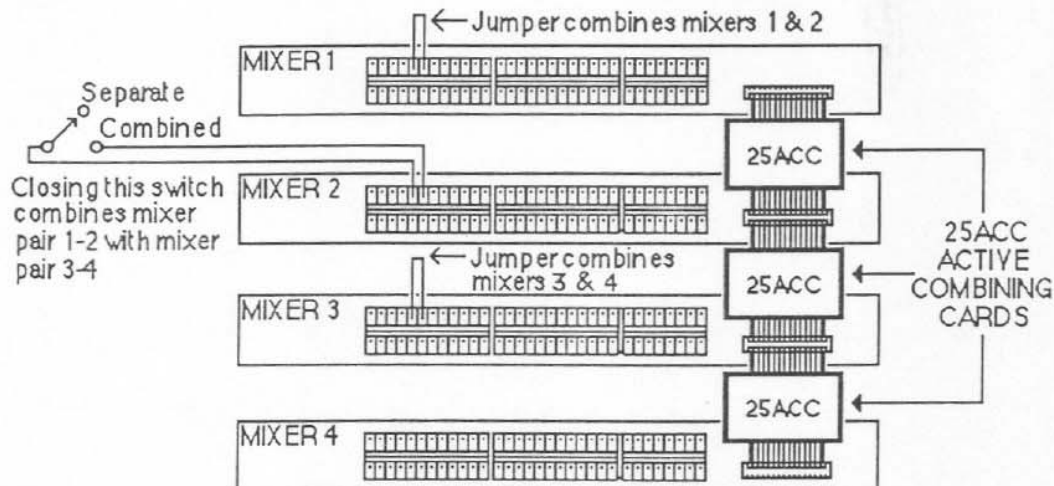

FOUR MIXERS COMBINED TO MAKE TWO SIXTEEN INPUT MIXERS THAT MAY BE COMBINED INTO ONE THIRTY-TWO INPUT MIXER

The combined audio output of all mixers will appear at the output of each individual mixer. When 2 mixers are combined they still retain some independent operating functions. These functions PRE-GATE MIX, REMOTE control and THRESHOLD control.

25ACC & 25PCC INSTALLATION

The 25ACC active combining card and the 25PCC passive combining cables are optional accessories to 2509 mixer. They are required if 2509s are to be combined in any configuration. These cards are installed between the COMBINE I/O connections located on the rear of the mixers.

These cards are plugged onto and between adjacent 2509 mixers. The illustration below depicts proper orientation and alignment of the 25ACC & 25PCC mixers.

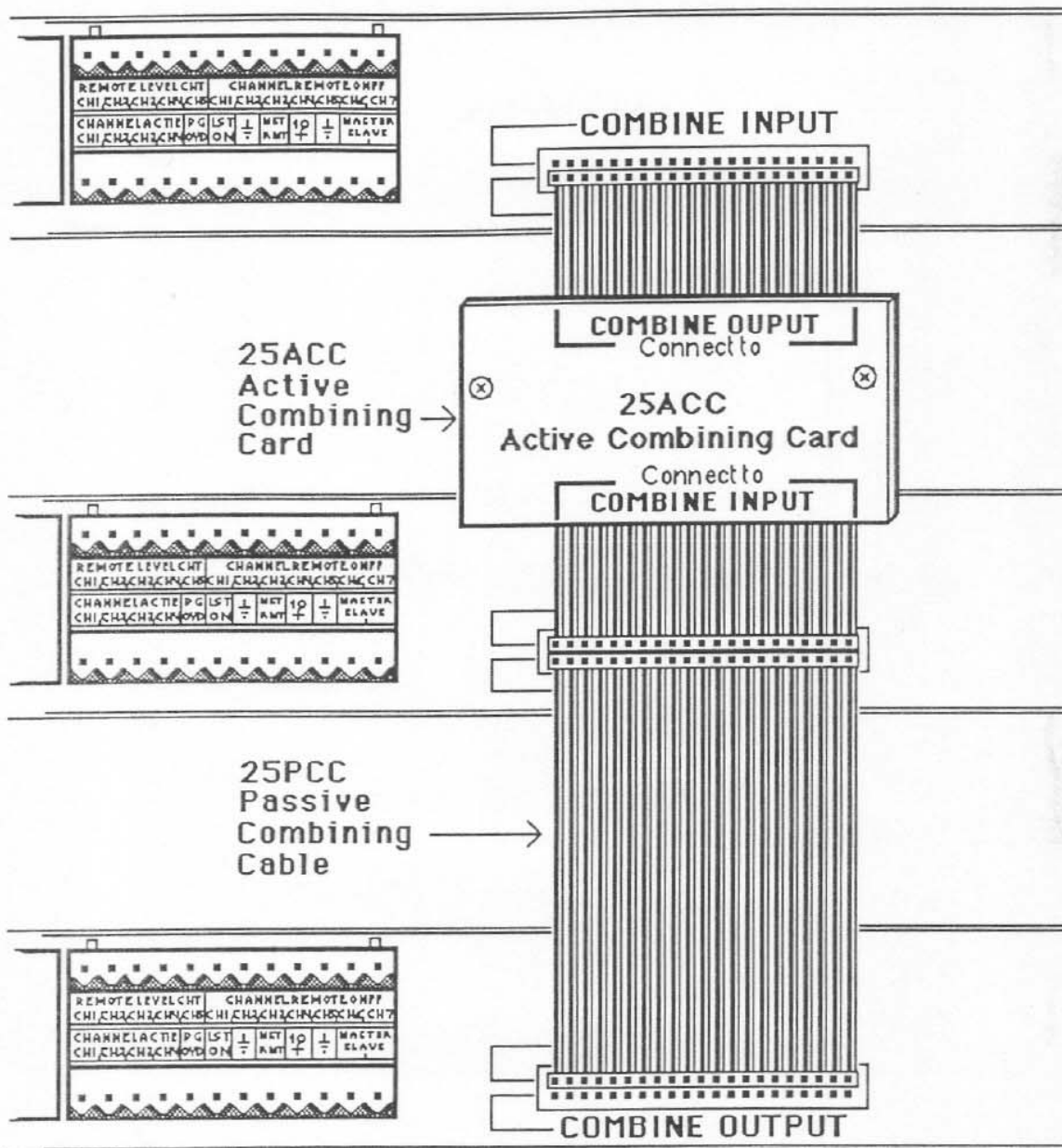

MASTER VOLUME CONTROL OF COMBINED MIXERS

What happens to the Master volume control of individual mixers when they are combined? There are two possibilities. The first possibility is that nothing happens, i.e. all mixers retain their own independent master volume control the same as before they were combined. The other possibility is that when the mixers are combined, the first mixer in the series chain has the only active master volume control.

The first option allows for independent zone control even when mixers are combined. The second option allows for only one master volume control per combined set of mixers to be in operation at a time. The master volume control on the first mixer in the combination is the operational control.

Both options can be used with the remote master volume control as well as the front panel master control. As with all remotes the front panel control is operational unless the remote is connected, the remote has precedence.

The desired option is selected at the time of 25ACC card installation. A wire jumper on this card determines which option will be in use. If the jumper is in place then only the master volume control on the first cor mixer will be operational. If the jumper is not installed then all master volume controls will remain oper when mixers are combined.

The illustration below shows the location of the jumper that determines the configuration of the volume controls when 2509s are combined. Note that the cover of the 25ACC must be removed to the wire jumper. The cover can be removed after the two screws that fasten it to the box are removed.

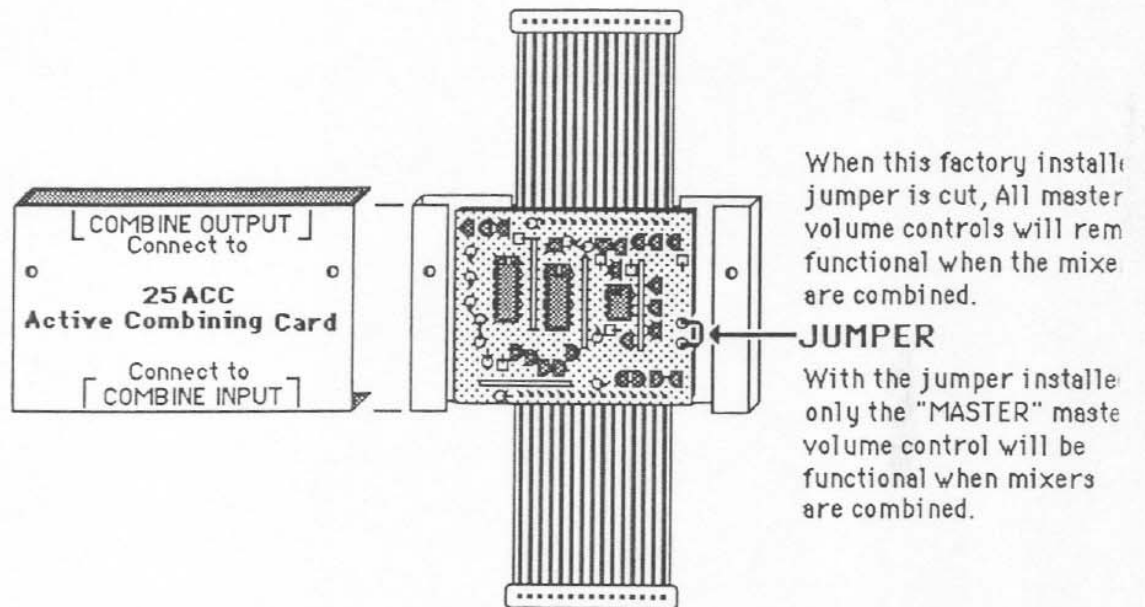

SPECIFICATIONS

Frequency response: ± 1 dB, 20Hz to 20kHz (ref @ 1kHz)

Total harmonic distortion: <0.1%, 20Hz to 20kHz @ +18 dBm

Equivalent input noise: <-126 per channel, A-weighted (150 input termination)

Maximum voltage gain: 78dB

Microphone input impedance: 6,800 ohms actual, electronically balanced. Recommended input impedance 150-600 ohms.

Line input impedance: 20,000 ohms electronically balanced

Phantom power voltage: 24 volts thru 3,400 ohm resistors

Output load impedance: 600 ohms or greater, transformer balanced

Maximum output level: +18 dBm

Pre-Vca output impedance: 604 ohms

Pre-Vca output level: +3 to +60 dB relative to input level; approx. 18 dB below master output level.

Pre-Vca Mix output impedance: 604 ohms

Pre-Vca Mix output level: 6 dB below master output level at zero attenuation

Post-Vca output impedance: 604 ohms

Channel off attenuation: 0 to -90 dB

Channel release time: 1 to 10 seconds

Channel active or Logic output: open collector type capable of sinking 200 mA @ 30 Vdc

High pass filter: -6dB @ 125 Hz, -30 db @ 32 Hz

Power consumption: 11 watts

Dimensions: Height - 4.45 cm (1.75 in.)
Depth - 26.67 cm (10.5 in.)
Width - 48.26 cm (19 in.)

Weight: 4.28 kg (9.5 lb)

Shipping weight: 5.40 kg (12 lb)

2509 BLOCK DIAGRAM

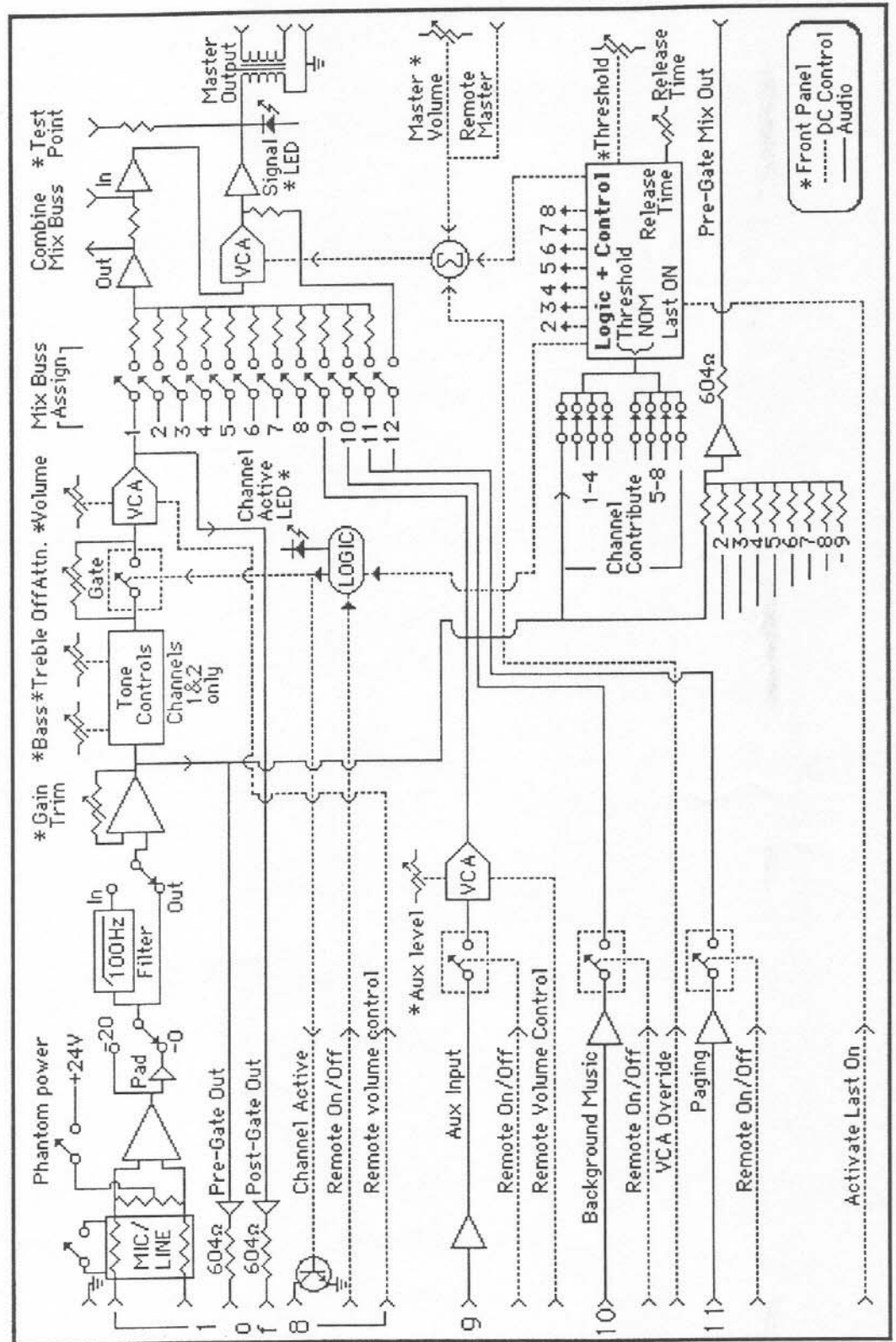

2508/2509 INPUT/OUTPUT CONNECTIONS

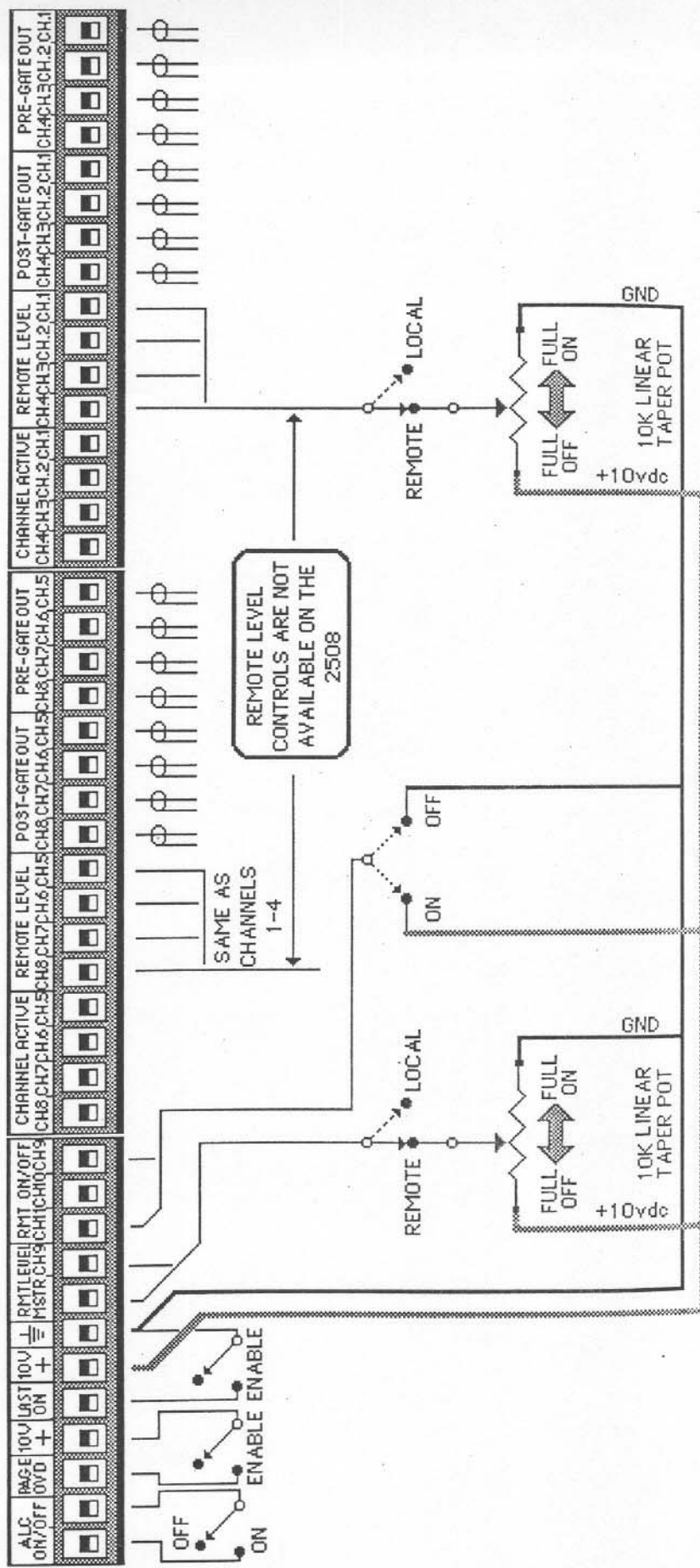
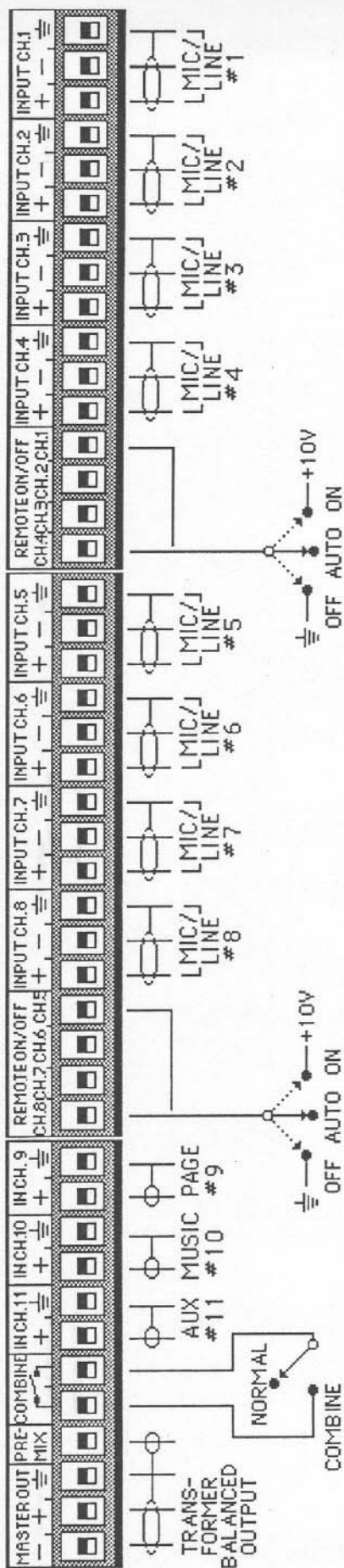

APPENDIX A

A FEW THOUGHTS ON MICROPHONE SELECTION

All microphones used with the 2504 are an integral part of the automatic mixer "system". Therefore the selection and placement of these microphones should be given careful consideration.

The 2504 determines which microphone(s) if any, should be gated on by a comparison process. Each individual microphone signal is compared to all the microphone signals summed together. These summed signals are considered by the mixer to be the ambient noise. The signal at each individual microphone is considered to be the desired signal. The individual microphone will be gated on only when the signal at that microphone exceeds the ambient noise level (as sensed by all the microphones) by a certain amount. This amount is determined by the setting of the threshold control.

Let us consider the condition when there is no one talking to any of the microphones. There is only the ambient noise in the room. All microphones are sending the same signal to the mixer. Each individual microphone is constantly being compared to the summed and weighted signal of all the microphones. Since no one single microphone level is significantly greater than any other microphone level; no microphones are gated on. Because of this comparison process it is logical to assume that it can be aided or enhanced by using the same type of microphone throughout the system. **This brings us to the first suggestion: When feasible use the same type of microphone throughout the system.**

Now that we have an idea of how the automixer works, let us consider the application below. This is a discussion panel application in which there is one microphone per person.

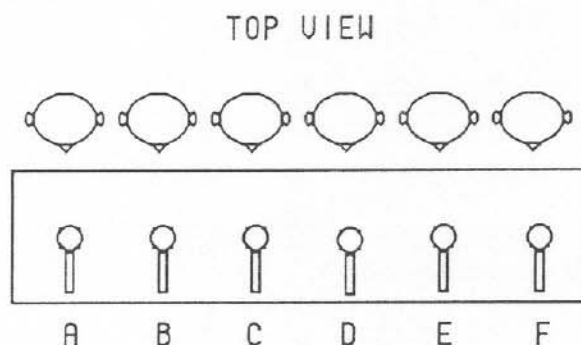

The reason for using an automixer is to maximize the gain-before-feedback potential in the room. By keeping unused microphones gated off, there is more gain available for the microphones in use. It then makes sense that we should design the system so that any unnecessary or false triggering of the microphones is minimized. In the above example when the person at microphone "C" speaks, we only want microphone "C" to gate on. It is undesirable to gate on microphones "B" and "D".

This can be accomplished by proper microphone selection and placement. First of all the microphone should be located as close to the talker, and as far away from other sound sources as possible, nothing new here. This gives us a signal to noise ratio advantage at the microphone. The signal being the talker and all other sound sources being the noise. **Suggestion number two: place the microphone as close to the talker as possible.**

The signal to noise ratio of the microphones can further be enhanced by using directional microphones. Typically a cardioid, super-cardioid or hyper-cardioid polar pattern is desirable. These microphones are either "Single-D" or "Variable-D" design. It has been proven that a directional cardioid microphone will provide an increased working distance of approximately 1.6 to 1. This means that a cardioid microphone will provide 6 dB of rejection to room noise at 1.6 feet that an omnidirectional microphone would at 1 foot.

Suggestion number three: use a directional microphone. It will provide you with a system more immune to false gating than a system using omnidirectional microphones.

Pressure zone type microphones are not particularly recommended for use with the automixer. Although they have a hemispherical polar pattern they do not exhibit as high a directivity index as a typical directional microphone. Shotgun or line type microphones are not recommended either. Their highly directional polar pattern is desirable, however their gain before feedback characteristic is not as good as a standard cardioid microphone.

Suggestion number four: shy away from pressure zone and shotgun type microphones.

Suggestion number five: there are exceptions to suggestions number one through

APPENDIX B

AUTOMIXER SET UP PROCEDURE

For proper operation, the automixer requires on-site adjustments, preferably under actual operating conditions.

STEP 1 (Initial control settings)

Please set the following controls as described:

- All channel volume controls - full counter clockwise (full off).
- All channel gain trim controls - full counter clockwise (full off).
- Master volume control - full clockwise (full on).
- Threshold sensitivity control - full counter clockwise (maximum sensitivity).
- Turn off or disconnect (unplug) all microphones from the system.

STEP 2 (setting the channel gain trims on all microphone inputs)

NOTE: Activating the "Last ON" circuit will facilitate the setting of the gain trim controls.

The following procedure suggests that the both the master and individual channel volume controls be set to maximum gain. This is just a suggestion and is not a requirement. By setting these controls to maximum and properly setting the channel gain trim controls the system can be made less susceptible to feedback due to user gain adjustments.

With the volume controls set to maximum the user cannot add any more gain to the system. If you do not anticipate adjustments by unauthorized users then it is not necessary to set these controls fully clockwise. You may wish to set the controls to the two o'clock position.

It is very important that as gain trim adjustments are made, that **one and only one channel is gated on at a time**. Remember that the NOM will cause a reduction in gain of 3 dB when a second channel is gated on. If you adjust the gain level to just below feedback with two channels gated on, then when the second channel gates off, the system will be 3 dB into feedback.

With one microphone gated on, and with that channel volume control set to a level your choice, adjust the gain trim to a comfortable level below feedback. This is best accomplished with someone talking into the microphone.

STEP THREE (set all other microphone inputs)

Repeat step two for all other microphone inputs. Remember that you must have only one channel active at a time. To achieve this just unplug all but one microphone.

STEP FOUR (adjust the threshold control)

NOTE: Deactivating the "Last ON" circuit will facilitate the setting of the threshold control. Set up the sound system as it will be used the majority of the time. With the threshold control set counter clockwise (maximum sensitivity), the individual microphones will gate on with any noise in the room. Typically, room noise will cause the channels to gate on and off in a random manner.

Setting the threshold level is a balancing act. It requires give and take. If the threshold is set to low, then the microphone channels will gate on and off will noise in the room. If the threshold is set to high then microphones will be very difficult to gate on with normal voice levels.

Imagine a balloon with a microphone inside it. The balloon represents the "pick up" area of the microphone. With the threshold control full counter clockwise, this balloon is extremely large and any sound in the room will cause the channel to be gated on.

As the threshold control is turned up (clockwise) the size of the balloon will shrink. This means that someone talking into the microphone will either have to speak louder or move closer to the microphone in order to be gated on.

This control is best set under actual operating conditions. Most times this is not possible so we do our best to simulate these conditions. Then, if possible, we return to do a final tweak during actual operating conditions. Please understand that you may not be able to obtain perfection. Setting of this control is a compromise. In order to have enough sensitivity for people who speak in a low voice you may have to accept some random gating.

You will want to do some role playing as a user of the system in order to set the threshold control. For example, in a church application someone would need to play the part of the minister. Better yet, get the minister to do as you adjust the system. Don't forget to play the organ to see the effect it might have on gating the microphones.

Set the threshold control as desired. This is best accomplished while monitoring the "Channel Active" LEDs on the front panel of the mixer as you make this adjustment. It will be necessary to have someone talk to the individual microphones.

Start by advancing the threshold control clockwise until random gating of the microphone channels ceases. Do this slowly as the release timer will continue to hold the channel on for a brief period of time as you advance the control. This could cause you to set the level artificially high.

Now talk into the various microphones. Do they gate on with appropriate sound levels? If not, you may wish to reduce the threshold level a bit.

Remember, that as the noise in the room increases, the microphones will need to have a greater sound level in order to gate on. You may wish to generate some typical room noise while checking the gating sensitivity of each channel. If one channel seems to gate on far easier than the other channels you may wish to reduce the gain trim control setting. You would need to make up for this gain reduction by increasing the level of the volume control.

STEP FIVE (set input levels)

Set all input level controls as required for normal operation.
Activate "Last ON" if desired.
Place caps on all knobs.

THIS CONCLUDES THE SET UP PROCEDURE