

EV **Electro-Voice**[®]
SERIES 52
TAPCO STEREO MIXERS

OWNER'S MANUAL

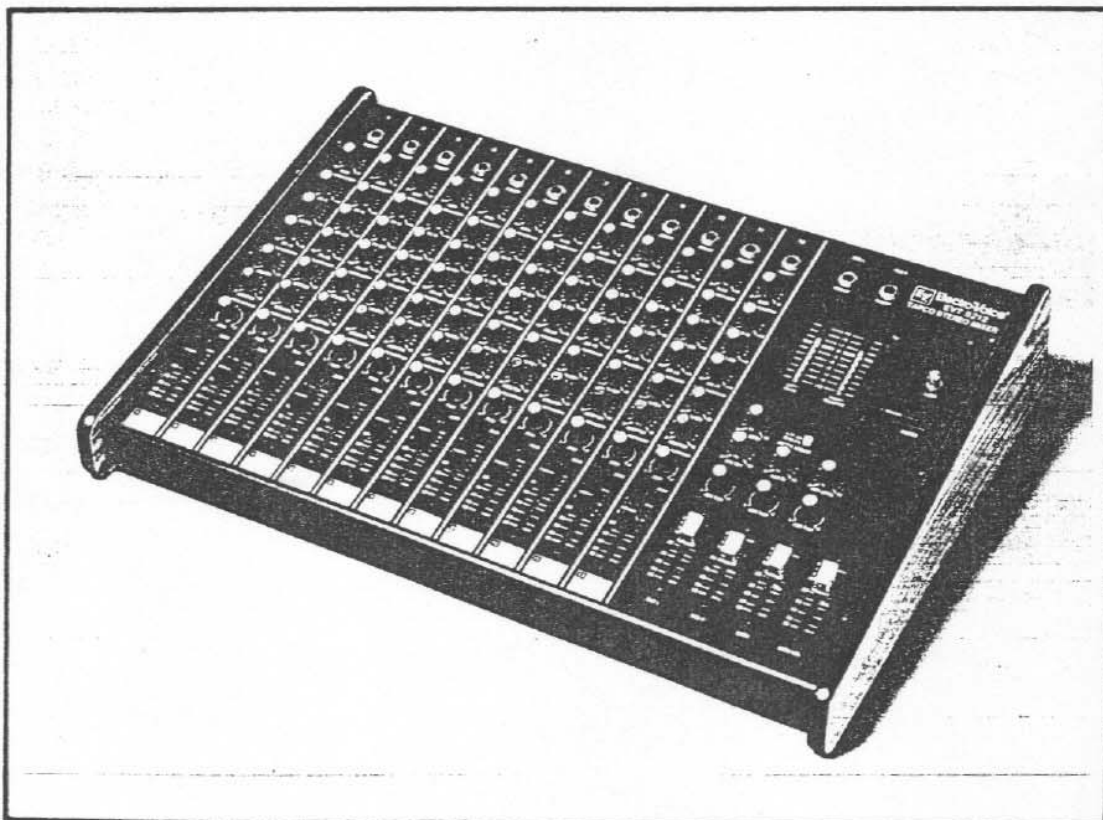

EVT 5212
STEREO MIXER

TABLE OF CONTENTS

I INTRODUCTION
SPECIFICATIONS
SIGNAL FLOW DIAGRAM

1. INPUT CHANNEL CONTROLS
AND FUNCTIONS

- 1A Gain
- 1B Equalizers
- 1C Effects Reverb Send
- 1D Monitor Send
- 1E Pan Pot
- 1F Channel Fader
- 1G Peak LED
- 1H Channel Patching Insert Jack

2. OUTPUT SECTION CONTROLS
AND FUNCTIONS

- 2A EFX Master Send
- 2B EFX Return Level
- 2C EFX PAN
- 2D AUX IN
- 2E AUX PAN
- 2F Reverb Section
- 2F1 Reverb Level
- 2F2 Reverb PAN
- 2G Master Section Controls
- 2G1 Left Submaster
- 2G2 Right Submaster
- 2G3 Main Master
- 2G4 Monitor Master
- 2H Meter Assignment Switch
- 2J LED VU Indicators
- 2K Sub Group Insert Jack
- 2L Lamp Output Connector
- 2M Power Switch
- 2N Power Indicator Led

3. REAR PANEL INPUT CONNECTORS

- 3A Balanced Low-Z Mic Input
- 3B High-Z Line Input
- 3C Effects Return
- 3D AUX IN
- 3E Effects IN
- 3F Monitor IN

4. REAR PANEL OUTPUT CONNECTORS

- 4A Sub R – Right Subgroup Output
- 4B Sub L – Left Subgroup Output
- 4C Main Output
- 4D Monitor Output
- 4E Effects Send

5. TROUBLESHOOTING

6. SCHEMATIC DIAGRAMS

WARRANTY

FACTORY SERVICE

Py SERIES 52 TAPCO STEREO MIXERS

GENERAL SPECIFICATIONS

FREQUENCY RESPONSE (± 1 dB)
 Mic In to any output, 20 Hz - 20 kHz
 EQ Flat, all faders nominal

DISTORTION
 Total Harmonic Distortion
 THD 20 - 20 kHz at +4 dB less than 0.05%

THD 20 - 20 kHz at +20 dB less than 0.10%

I.M, SMPTE, 1 dB below clip less than 0.10%

HUM and NOISE*
 (20 Hz - 20 kHz with 150 ohm input impedance)

EIN - equivalent input noise -128 dB

Residual at main out (all faders down) -90 dB

Residual at Monitor out -90 dB

Main out with Main, Subs and 1 fader at Nominal (44 dB total gain) -75 dB

Monitor out with Monitor Master and 1 Fader at Nominal (44 dB total gain) -80 dB

INPUT CHANNEL EQUALIZATION

LOW - Shelving at 100 Hz ± 15 dB

MID - Peak/notch at 3 kHz ± 12 dB

HIGH - Shelving at 10 kHz ± 15 dB

MICROPHONE INPUTS*

Low Impedance, Balanced, Pin 2 reference positive

EIN (20 Hz - 20 kHz: 150 ohm source)** -128 dB

Maximum Input Level +8 dB (2.0V)

Input Impedance at 1 kHz 6 K ohms

CMRR - Common Mode Rejection Ratio 65 dB typical

CMRR- Ratio (60 Hz- 10 kHz) 50 dB min.

SLEW RATE (measured at Insert Jack) 15 V./ μ sec

CROSSTALK

Adjacent Inputs 1 kHz -75 dB typical

Input to Output 1 kHz -75 dB typical

All combinations -50 dB minimum

20 Hz - 20 kHz

LAMP CONNECTOR

BNC connector

12.6 V ac/0.20

amps Max.

LEVEL DISPLAY*

10 Segment LED in

3 dB steps

Reference "0"

Response

-18 dB to +9 dB

+4 dB

Full wave, Average

Responding

DIMENSIONS

	Model 5208		Model 5212		Model 5216	
	mm	in.	mm	in.	mm	in.
Height	143	5-5/8	143	5-5/8	143	5-5/8
Depth	480	18-7/8	480	18-7/8	480	18-7/8
Width	528	20-3/4	680	26-3/4	832	32-3/4
Net Weight	kg	lb	kg	lb	kg	lb
	10.7	23-1/2	13.8	30-1/2	16.8	37

POWER REQUIREMENT

25 Watts max.

Available for 95 - 130 Volts, 50/60 Hz or

190 - 260 Volts, 50/60 Hz as indicated on

rear panel.

HIGH LEVEL INPUTS

	Max. Level*	Input Impedance, Ohms	Max. Source Impedance, Ohms
Left insert	+20 dB	100 K	-
Right insert	+20	100 K	-
Efx return	-	≥ 25 K	-
Efx input	+40	25 K	-
Monitor input	+29	10 K	-
Aux input	-	≥ 16 K	-
Input chan insert	+20	1.8 K flat EQ	100
	+5	1 K max boost EQ	

OUTPUTS

Max. level (± 1 dB) into min. load impedance

	Max. Level, dB	Min. Load, Ω	Internal Impedance, Ω
Main	+20	600	50
Monitor	+20	600	50
Left sub	+20	600	50
Right sub	+20	600	50
Left insert	+20	600	50
Right insert	+20	600	50
Efx send	+20	600	50
Input chan insert	+20	2000	100

* 0 dB is referenced to 0.775 Volt, RMS.

** Theoretical minimum noise is -130.8 dB across 150 ohms.

Py SERIES 52 TAPCO STEREO MIXERS

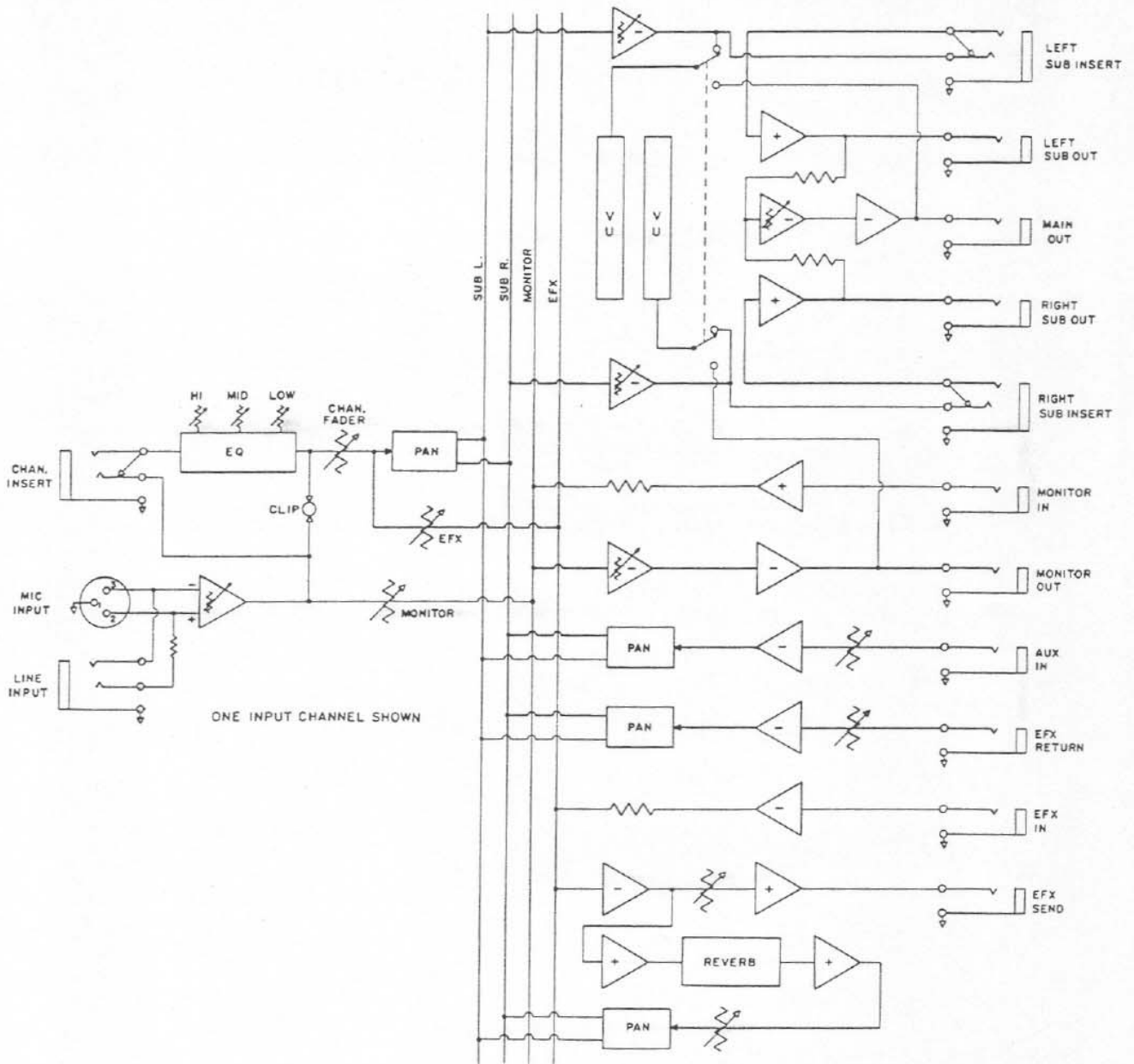

SIGNAL FLOW DIAGRAM

SECTION 1.0

1.0 INPUT CHANNEL CONTROLS (Figure 1)

The input channel is the beginning of the mixer. Each input channel will accept one signal source which then may be sent to a monitor system, be equalized, have reverb or other effects added, and last but not least, be sent to the main system for the audience to hear. Each input has a low impedance microphone input (the 3 pin XLR or Cannon connector) and a high impedance mike or line input (1/4 in. phone jack). The line input will accept signals from an instrument, high impedance microphone, tape machine, electronic drummer or almost any other audio source. Always make sure that the channel fader (sect. 1F) or master faders (sect. 2G) are down before plugging or unplugging input sources.

IA. GAIN RED CONTROLS

The GAIN control adjusts the gain or amplification of the input amplifier. This is necessary to accommodate the wide variation in signal strength presented to the mixer by the almost endless variety of signal sources — vocal mics, instrument mics, instruments, tape machines, etc. The GAIN control allows you to optimize the amplification for each input source. This results in the best signal to noise ratio (. . . no hiss) and at the same time, best freedom from overload distortion.

The GAIN control is used to match the gain of the first preamp stage to the signal strength of the source being run through the channel. To get the cleanest, quietest operation from the board it is important that the GAIN control be properly set. To set up a mix, first put all the input and sub-group slide faders at "10". Then adjust the GAIN controls for a rough mix, and do the fine tuning with EQ and faders as necessary. Whenever possible, it's best to try to maintain that "straight line" relationship between all faders. When this is done, all the levels within the console are very close to being optimized for the best noise and distortion performance. Once the correct GAIN setting is established, make all volume adjustments with the appropriate channel fader (sect. 1F).

In general, the lowest noise operation (greatest dynamic range) will be obtained when the GAIN control is set at a point where the PEAK light flashes occasionally but not frequently.

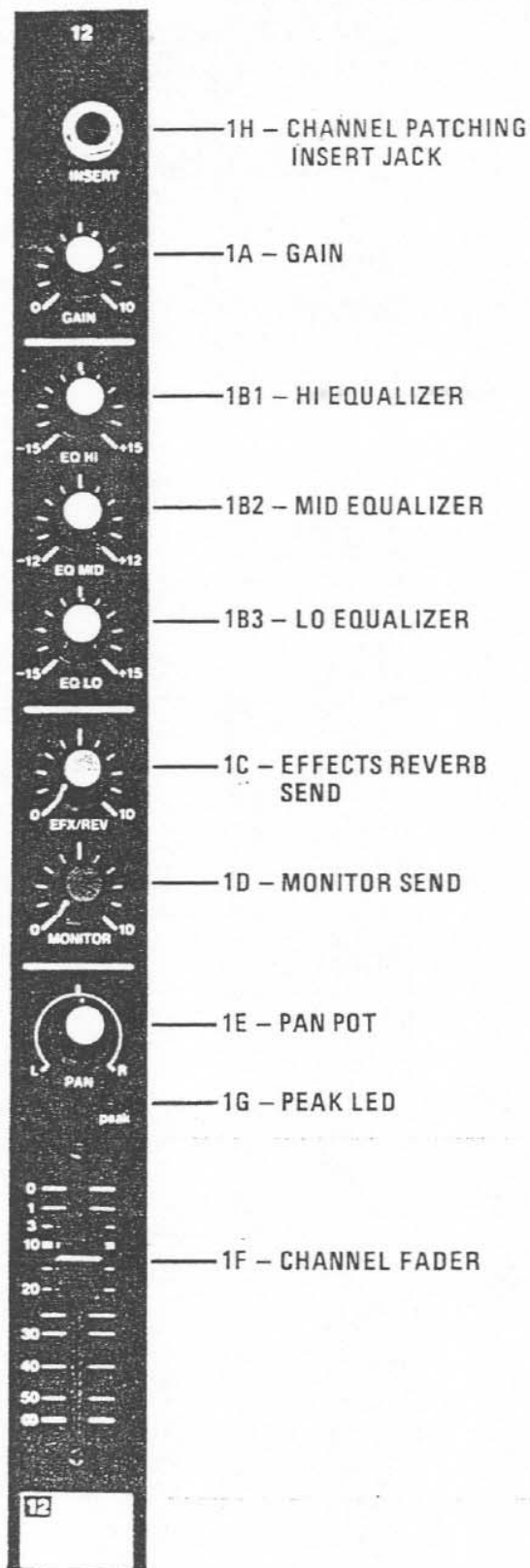

FIGURE 1 - Input Channel Functions

Ey SERIES 52 TAPCO STEREO MIXERS

1B. EQ CONTROLS GRAY CONTROLS

Equalization can be more simply described as tone control. The EQ circuits used in the 52 Series have a substantial amount of boost and cut capability.

This wide range can be a bonus, when dealing with instrument signals, bad acoustics or other problems. Use them sparingly however, for the best results.

1. HI EQ 10 K Hz SHELVING TYPE ± 15 dB

Controls the treble content of the input signal. Turning the control counter-clockwise decreases the amount of treble, clockwise increases it.

2. MID EQ 3 K Hz PEAK/DIP ± 12 dB

Controls the midrange content of the input signal. Turning the control counter-clockwise decreases the amount of midrange, clockwise increases it.

3. LO EQ 100 Hz SHELVING TYPE ± 15 dB

Controls the bass content of the input signal. Turning the control counter-clockwise decreases the amount of bass, clockwise increases it.

1C. EFX/REV SEND BLUE CONTROLS

The EFFECTS/REVERB send control determines how much of that input signal is sent to the internal spring reverb and/or external effects. It is affected by the channel tone controls (sect. 1B) and the channel fader (sec. 1F).

Turning the control clockwise increases the amount of reverb and/or effects applied to that input, counter-clockwise decreases the amount.

Since each channel has its own EFFECTS/REVERB send, some channels can have reverb or effects and others none. Note that since the internal reverb and external effects share a common send, they will always have the same sources. That is; it is not possible to have reverb on one input source and

effects on another input source at the same time (unless the insert point is used). It is possible to have reverb and effects simultaneously on both input channels; however.

The EFX/REVERB send may also be used as mono send. This might be useful for a tape recorder send, for instance.

1D. MONITOR SEND GREEN CONTROLS

The monitor send control sets the level of that input signal in the monitor mix. It is independent of all input channel controls except the GAIN control (sect. 1A). It is not affected by the channel tone controls or slide fader. Thus, it is independent of, and not affected by, changes in the main or house mix.

SECTION 1E

1E. PAN POT YELLOW CONTROLS

Short for "panoramic potentiometer". This control allows you to place the channel's input signal within the stereo image by assigning more or less of the signal to the left or right sub master controls.

Turning the panpot to the left of center moves the apparent source toward the left channel turning it to the right moves the source toward the right channel. Centering the control makes the apparent source centered between the channels. If all inputs are panned center, the result is mono. Proper use of the PAN control can sometimes help to control acoustic feedback in a sound reinforcement system by "panning" a mic away to the loudspeaker on the opposite side of the stage.

1F. CHANNEL FADER BLACK SLIDER

The slide fader controls the output level of the channel as it's fed to the sub-groups. The control should be normally set at the "10" mark. With all controls set to their designated normal operating points, all circuits in the board are optimized from both noise and distortion standpoints. In other words, the signal levels are high enough to keep noise from creeping in and low enough to ensure plenty of headroom and freedom from clipping distortion. If the fader must run wide open to get enough level, turn up the GAIN control or increase the setting of the L and R

EV SERIES 52 TAPCO STEREO MIXERS

stereo MASTERS. Conversely, if the fader must be pulled way back to get the right level, the GAIN control or stereo MASTERS should be adjusted. Adjust the GAIN control if you see a PEAK LED indication, otherwise adjust the stereo MASTERS. For optimum performance, the channel FADERS should always be run as close to the "10" mark as possible.

1G. CHANNEL PEAK LED

The channel PEAK LED monitors the input channel circuit for clipping or overload (both before and after the EQ section). If it lights, you are bordering on distortion. You'll hear this in the output as a harsh, blaring sound on volume peaks. This might be caused by excessive boost in the channel equalization controls (sect. 1B), or a GAIN control setting that is too high for the input signal (sect. 1A). Generally, readjusting the GAIN control (sect. 1A) will suffice.

1H. CHANNEL PATCHING INSERT JACK

This space saving (two-connectors-in-one) jack allows you to add external signal processing gear to a particular channel, without disturbing any of the other channels. A 3-conductor (stereo) phone plug is used for both the output from the channel preamp, and for the return from the mixer's output stages from the external processing device. The diagram indicates how a channel patching cord should be wired. These can also be purchased from PRO-CO SOUND or other audio cable manufacturers.

HOW TO WIRE A CHANNEL PATCHING CORD

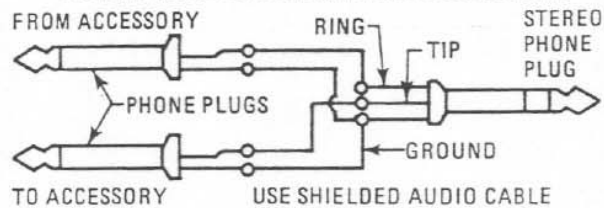

The channel patching jack can be used with equalizers, limiters, compressors, external reverb or delay systems and the like. Just be sure the device you want to patch in has *line level* unbalanced inputs and outputs. The signal at the insert jack can drive loads of 2000 ohms or greater, and the external processing device should have a low output internal impedance (100 ohms or less).

A nominal input signal is a level of -10 dB; the maximum level is $+20$ dB.

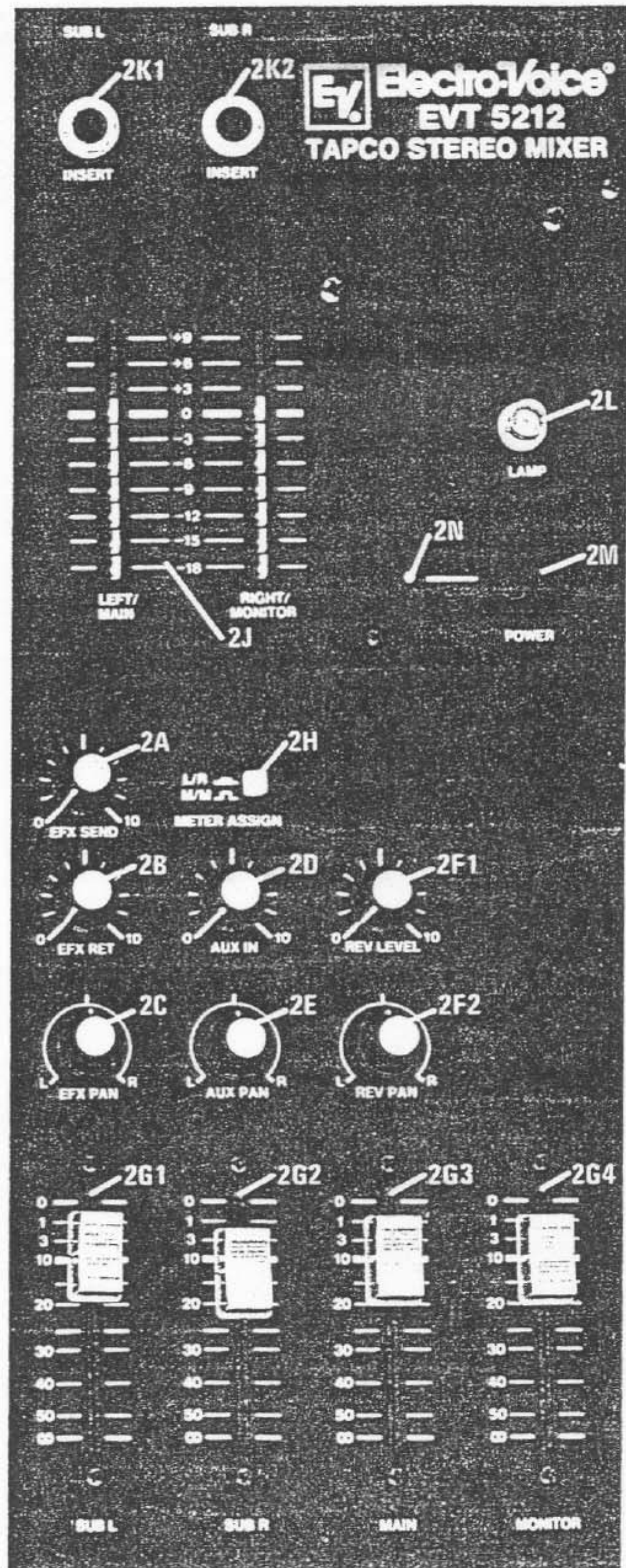

FIGURE 2 - Output Section Controls and Functions

FY SERIES 52 TAPCO STEREO MIXERS

SECTION 2.0

2. OUTPUT SECTION CONTROLS (Figure 2)

2A. EFX MASTER SEND BLUE CONTROL

The EFX (effects) SEND control sets the level of the signal appearing at the effects send output jack going to any type of outboard effects device(s) such as delay, phaser, flanger, etc. It does not affect the signal being sent to the internal reverb system. The source for this signal is via the individual effects/reverb send level controls (sect. 1C) on input channels 1 through 12.

2B. EFFECTS RETURN LEVEL RED CONTROL

The EFX RETURN level control determines the amount of externally generated effects signals in the main mix. This signal is mixed into the left and right stereo sub outputs, via the EFX PAN control.

2C. EFFECTS PAN YELLOW CONTROL

The EFX PAN control directs the signal coming from the effects return level control into the left and/or right sub busses. The control works in an identical way to the input channel PAN control.

2D. AUXILIARY INPUT RED CONTROL

The AUX IN control is used to set the level of inputs that will be directed to the L/R sub busses through the AUX PAN control (2E). The AUX IN is one of three input locations that can be used to stack mixers together without using up an input channel.

2E. AUXILIARY PAN YELLOW CONTROL

The AUX PAN control directs the signal coming from the AUX input into the left and/or right sub bus. The control works in an identical manner to the input channel PAN control.

2F. REVERB SECTION

Reverberation is the natural decay of sound in a closed space (room). The internal reverb system uses springs to realistically simulate this effect.

The reverb section gets its input signal from the EFX/REVERB send controls on the input channels (sect. 1C).

1. REVERB LEVEL RED CONTROL

The REV return LEVEL control adds reverberation to the main (left and right sub) outputs from any input channel signal (inputs 1 through 12) whose EFX/REV control is turned up.

Turning the control to the right increases the amount of reverb present in the main (left and right sub) outputs.

2. REV PAN YELLOW CONTROL

The REV PAN control directs signal from the REV LEVEL control to left or right sub bus. The control works in an identical manner to the input PAN control.

2G. MASTER SECTION CONTROLS

The master section controls affect the overall subgroup main and monitor mixes.

A. Subgroup can be demonstrated by this example: If the input channel PAN controls are set fully clockwise for all the vocal microphones, then we will have assigned the SUB R slider as a "vocal submaster." If we raise or lower the SUB R control we can set the proper vocal level in the mix while preserving the input channel balance set among the vocalists.

1. LEFT SUBMASTER

Controls the volume of the left stereo output channel, it is also used as a subgroup master.

2. RIGHT SUBMASTER

Controls the volume of the right stereo channel. It is also used as a subgroup master.

3. MAIN MASTER

The MAIN (monaural) output is an equal mix of the left and right stereo outputs. The MAIN MASTER controls the volume of the output.

4. MONITOR MASTER

Controls the volume of the monitor output signal. The monitor output is a mix of the individual channel monitor sends.

2H. METER ASSIGNMENT SWITCH

A push-push switch is provided to allow the user to select the points in the circuit which are monitored by the LED VU indicators. When the switch is depressed, the indication will be the audio level at the left sub and right sub outputs. In the other (non-depressed) position, signal level at the main and monitor outputs will be shown.

2J. LED VU INDICATORS

A vertical row of ten light emitting diodes is used to indicate signal level at selected points in the circuit (see assign. switch). This type of display is free from overshoot (ballistic) problems of mechanical meters, and is highly visible under poor lighting conditions. Each indicator is calibrated in volume units, such that 0 dB corresponds to an output of 1.228 volts, which is +4 dB, a standard in the industry. The mixer provides 16 dB of headroom above this level for superior sound reproduction. It may be necessary in some cases to reduce the sensitivity of equipment fed by the mixer, such as a power amplifier, to prevent overdriving it. A gain control on the amplifier is usually provided for this purpose.

2K. SUBGROUP INSERT JACK

This jack provides a convenient point to add signal processing devices to the complete left/right submaster mix. The jack is wired the same as the channel insert jacks. The output can drive 600 ohms or greater unbalanced loads up to +20 dB and the inputs can accept +20 dB before clipping.

2L. LAMP CONNECTOR

A BNC type socket is provided on the right hand side of the mixer panel to accommodate a *Littlite** gooseneck lamp, and allow operation of the board under dark conditions. The 18 inch long "G" series is available from many professional sound dealers, and attaches without tools. The voltage at the socket is 12.6 V.A.C. at a maximum of 0.2 amps.

2M. POWER SWITCH

The power switch is used to turn on & off the a.c. mains power.

2N. POWER INDICATOR LED

This light emitting diode is illuminated when the a.c. mains power is on.

SECTION 3.0

3. REAR PANEL INPUT CONNECTORS (Figure 3)

The 52 Series mixer can accept program material covering a dynamic range of over 100 dB. Except for the high gain mic input all of the line inputs can safely accept signals at least up to +20 dB. (See Specifications for details)

Several of the inputs that directly access the busses can be used to stack mixers together without using up an input channel. The stacking group includes the AUX, EFX and MONITOR inputs.

3A. BALANCED LOW-Z MIC INPUT

A 3-pin XLR ("Canon") connector is used for balanced low impedance microphone inputs. The Mic Input is actively balanced; active balancing allows elimination of the input transformer (along with its limitations) while maintaining the RF and hum rejection of a good transformer coupled input.

Any of the 12 low impedance inputs may be used with a microphone equipped with its own power source. The input circuits are protected against the application of a positive d.c. potential of up to 60 volts on pins 2 and 3 of the input connector.

It is important that during operation or testing of the mixer, all channel faders remain fully down, whenever the mic input is not *properly* terminated with a microphone or equivalent 150 ohm source. An open input invites the introduction of high noise levels which could produce lower quality sound or an incorrect test measurement.

3B. HIGH-Z LINE INPUT

A standard 1/4 inch phone jack is used for unbalanced line level signals. Examples of line level signals include some electric and most electronic keyboards, synthesizers, turntables (with appropriate preamps), tape decks and the line outputs from other mixers. All input channel controls, including the variable GAIN control, affect the LINE Input. Maximum input level before preamp clipping is 40 V or +34 dB.

If a sufficient signal level is not possible with the GAIN control in its furthest clockwise position, the input signal must then be treated as a mic level signal. If necessary, use an appropriate balancing transformer (EV Model 502CP or equivalent) or a direct box and the microphone (XLR) input.

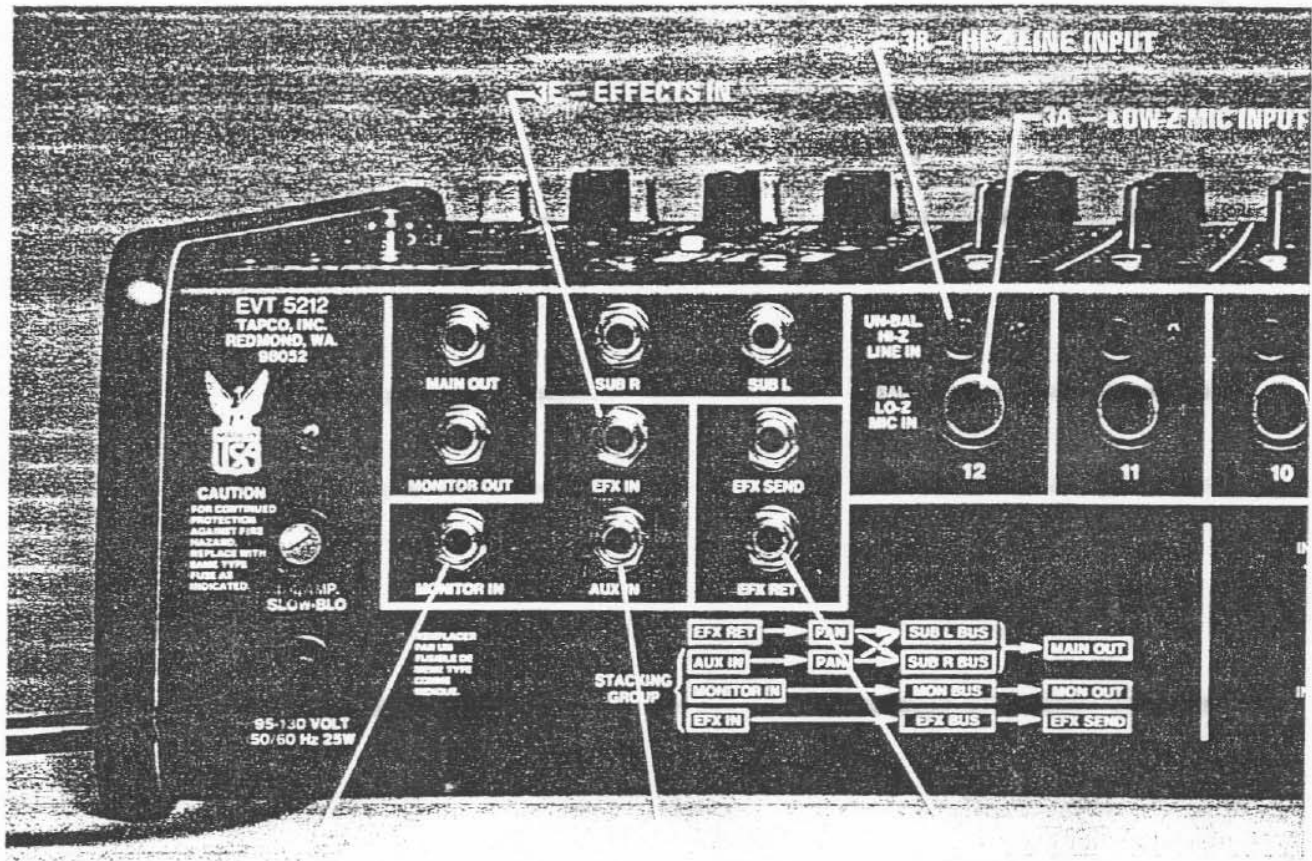

FIGURE 3 – Input Jacks

3C. EFFECTS RETURN

The EFX RET jack accepts line level input signals which can be set with the EFX RET level and the EFX PAN front panel controls. These effects are buffered from any reverb until they are intentionally mixed into the subgroup busses.

3D. AUX IN

The AUX IN jack is used for signals to be fed to the subgroup busses. The signal is controlled by the AUX IN level & AUX PAN front panel functions. The AUX IN is part of the "stacking group".

3E. EFFECTS IN

The EFX IN jack will put line level signals directly on to the effects bus. Crosstalk and buffering protection are provided by the input circuit; signal level is controlled by the external source. The EFX IN is part of the "stacking group".

3F. MONITOR IN

The MONITOR IN jack will put signals directly on to the MONITOR bus. Crosstalk and buffering protection are provided by the input circuit; signal level is controlled by the external source. The MONITOR IN is part of the "Stacking group".

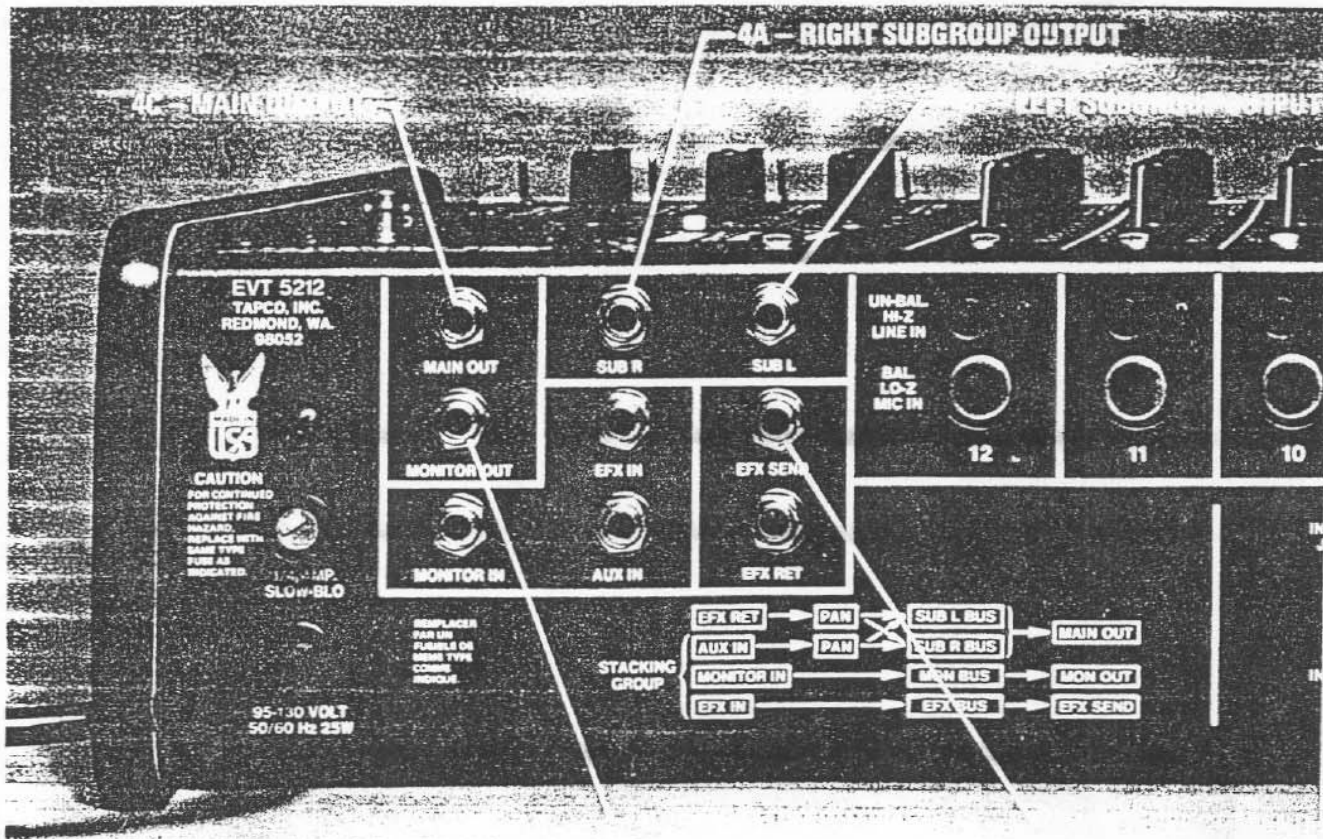

FIGURE 4 – Output Jacks

4. REAR PANEL OUTPUT CONNECTORS (Figure 4)

All output connections are unbalanced to ground and made through standard 1/4 inch phone jacks. Each output is capable of driving a 600 ohm, or greater, load to a maximum level of +20 dB. (See Specifications for details)

In the 52 Series mixer every output is "polarity coherent", that is, a positive going signal in any input or insert point will produce a positive going signal at every output.

4A. SUB R RIGHT SUBGROUP OUTPUT

This high level output is derived by summing all of the inputs (channels & external) assigned to the right subgroup bus. A PAN control rotated full clockwise to the "R" position will assign that signal only to the right bus.

4B. SUB L LEFT SUBGROUP OUTPUT

This high level output is the left subgroup equivalent of the Sub R output.

4C. MAIN OUTPUT

The MAIN OUT jack is a line level output that is a 50/50 mix of the right and left subgroups. Since the "52" is a true subgroup mixer all signals that appear in the main mix must come through the subgroup busses.

4D. MONITOR OUTPUT

The MONITOR OUT jack has a line level signal that is the sum of all of the input channel assignments and the external monitor input signal.

4E. EFFECTS SEND

The EFFECTS SEND output signal is the sum of all of the input channel assignments with the EFX/REV control plus any signal coming through the EFX IN.

5. TROUBLESHOOTING

5A. IN CASE OF DIFFICULTY

1. Don't panic, be systematic, change one thing at a time, Check the obvious!!!
2. Check all cables. 99% of all system problems are caused by poor cables.
3. If there are no lights, check AC power source, power switch and power fuse.
4. If the problem is one of a "dead" input, verify by trying the same source in another input.
5. Verify problems by substituting the bad part with one that works. Do this by moving the cable from the one that works to one that doesn't.
6. Fuses that blow instantly on turn-on are a sign of internal distress and mean that you should refer the unit to "qualified service personnel."
7. Don't panic, be systematic, change one thing at a time. Check the obvious!!!

5.1 SERVICE AND WARRANTY INFORMATION

CAUTION:

THERE ARE NO USER SERVICEABLE PARTS INSIDE OF THIS MIXER. LETHAL VOLTAGES PRESENT INSIDE CHASSIS. REFER ALL SERVICING TO QUALIFIED SERVICE PERSONNEL.

PLAIN LANGUAGE TEXT

Mixing Console (Electronics — Limited).
The EV/TAPCO mixing console is guaranteed for one year from date of original purchase against malfunction due to defects in workmanship and materials.

If such a malfunction occurs, the product will be repaired or replaced (at our option) without charge for materials or labor if the product is delivered prepaid to the proper service facility. This may be done in one of the following ways:

1. Take the mixer to an authorized TAPCO Inc. Warranty Service Center. A list of these service centers is available at all Authorized Dealers, or from any of the factory service locations.
2. Return the unit(s) to the appropriate factory service location.

Regardless of which option you choose, the responsibility for shipping and insurance to the service station or factory is yours. Shipping and insurance is prepaid by the service station or factory when the unit is returned to you. Freight collect shipments will be refused at our door(s).

NOTICE

Do not discard shipping carton or packing. Equipment must be shipped in original carton with packing or suitable roadcase.

TAPCO will not be responsible for damages occurring if shipment is not in original carton with packing or suitable roadcase.

This warranty does not cover appearance items or finish or malfunction due to abuse or operation at other than specified conditions. Damage to any related equipment that may have been caused by this EV/TAPCO product is also specifically excluded.

Unauthorized repair and/or modification by other than authorized TAPCO Inc. repair facilities will void your warranty.

In case of dispute, the stated Limited Warranty shall be the legal basis for any decision and supersedes this plain language text.

Series 52 TAPCO Stereo Mixers

6. SCHEMATIC

INPUT BOARD

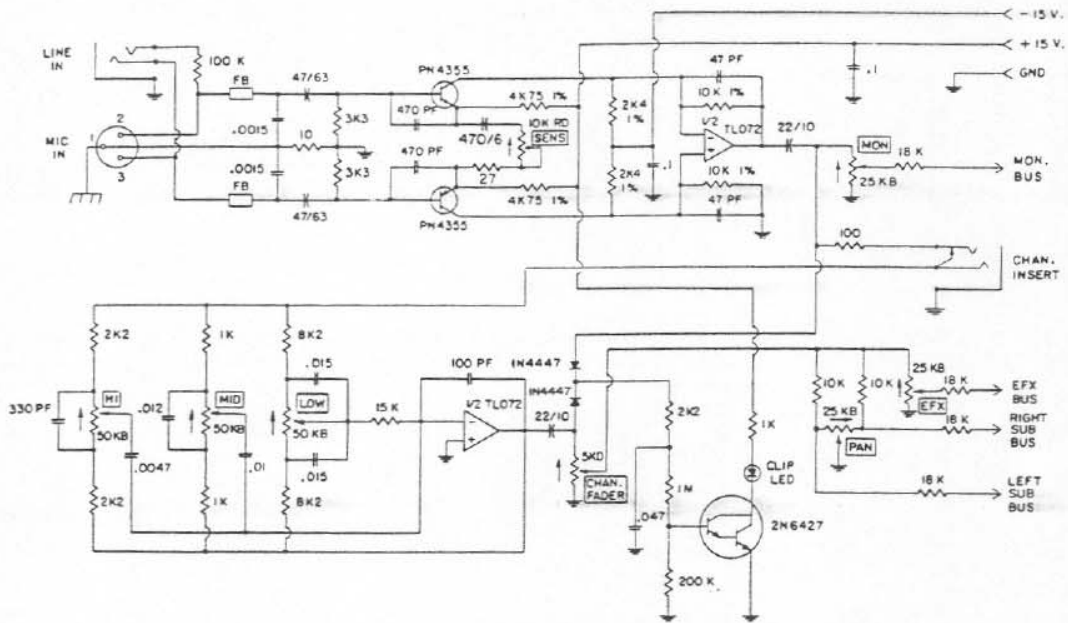

RIGHT SUB BOARD

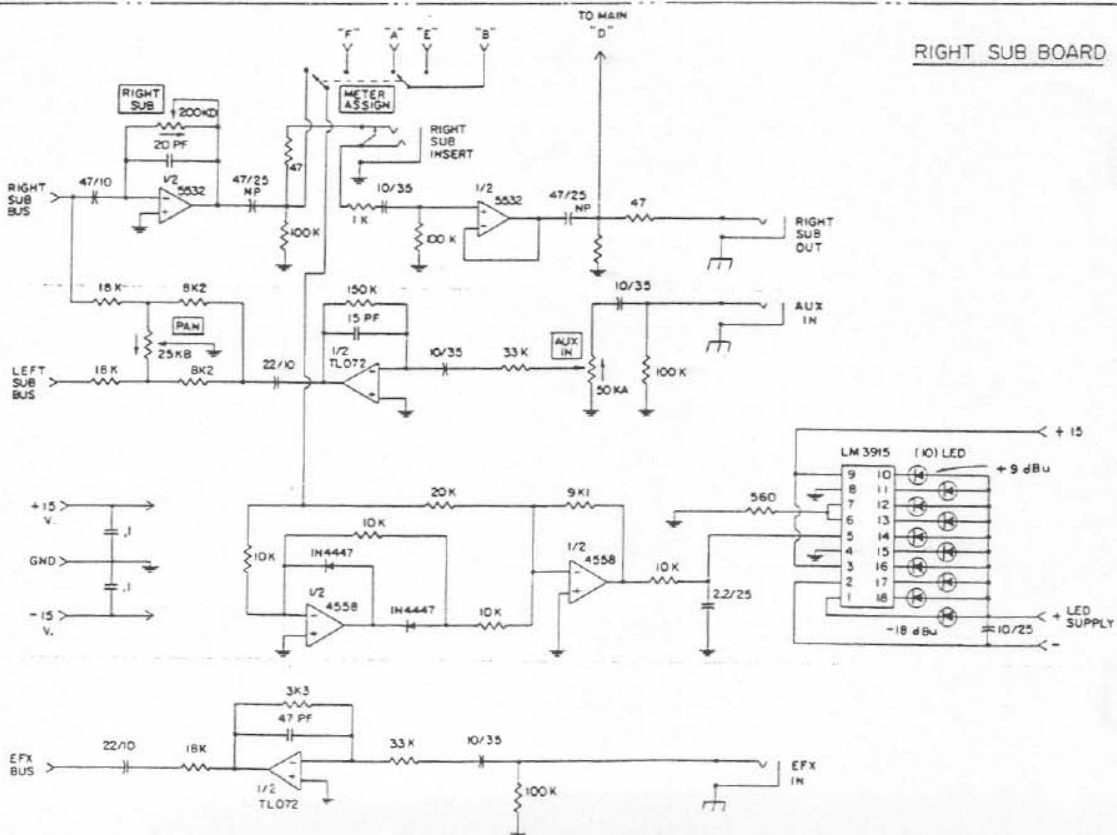

EV SERIES 52 TAPCO STEREO MIXERS

6. SCHEMATIC

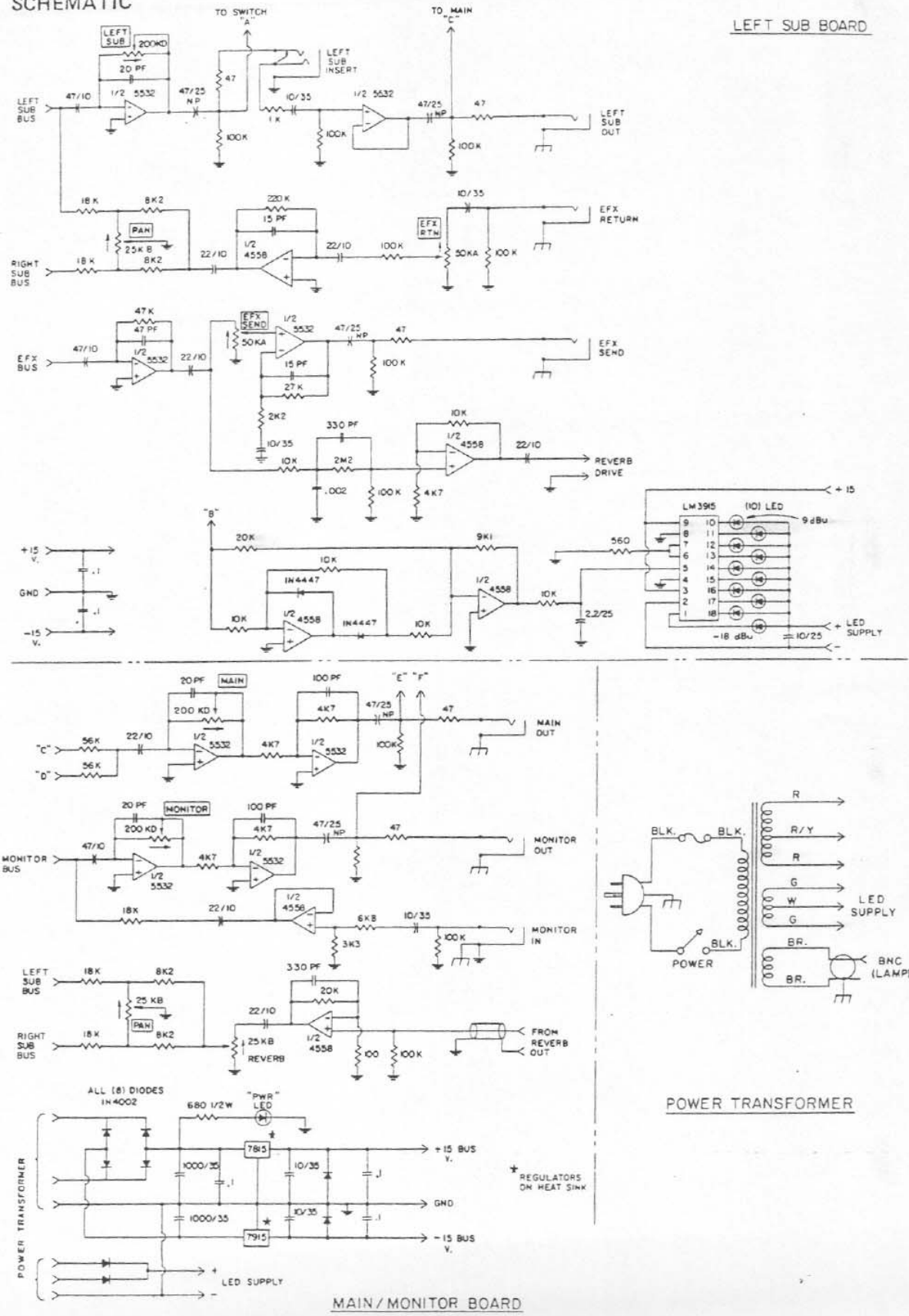

EV SERIES 52 TAPCO STEREO MIXERS

LIMITED WARRANTY

a. TAPCO Inc. warrants the materials, workmanship and proper functioning of this product for a period of one year. If any defects are found in the materials or workmanship of EV/TAPCO products, or if the product ceases to properly function within the appropriate warranty period from the date of first purchase, TAPCO Inc. will repair or replace any non-conforming materials through the nearest EV/TAPCO authorized warranty service center.

b. Purchaser must return the product to the EV/TAPCO authorized warranty service center, freight prepaid. A list of authorized warranty service centers is available from TAPCO Inc., Redmond WA. Claims must be sent to any EV/TAPCO authorized warranty service center. If claims are not resolved by the EV/TAPCO authorized warranty service Center, any warranty claim should be sent to:

TAPCO Inc.
3810 148th Ave. NE
Redmond WA 98052
(206) 881 9555

c. TAPCO Inc. reserves the right to inspect any products which are the subject of any warranty claim prior to repairing or replacing. Any products which do not conform to this warranty shall be repaired or replaced by TAPCO Inc. as soon as possible following receipt of the product and warranty claim, but in no event later than 30 days after receipt of the product. Out-of-warranty claims will be billed for labor and materials as required. Prepayment of these charges may be required. Any product for which a warranty claim is accepted will be returned to the purchaser and cost of shipping and insurance will be factory prepaid. This warranty gives specific legal rights. The purchaser also has implied warranty rights, and may also have other rights which vary from state to state.

d. This warranty is extended to the purchaser and to any purchaser from him for value.

e. THE ABOVE WARRANTY IS THE SOLE WARRANTY GIVEN BY TAPCO Inc. AND IS IN LIEU OF ALL OTHER WARRANTIES. ALL IMPLIED WARRANTIES, INCLUDING WARRANTIES OF MERCHANTABILITY OR FITNESS FOR ANY PARTICULAR PURPOSE SHALL BE STRICTLY LIMITED IN DURATION TO ONE YEAR FROM THE DATE OF ORIGINAL PURCHASE AND UPON THE EXPIRATION OF THE WARRANTY

PERIOD TAPCO Inc. SHALL HAVE NO FURTHER WARRANTY OBLIGATION OF ANY KIND WHETHER EXPRESS OR IMPLIED. INCLUDING BUT NOT LIMITED TO WARRANTY OF MERCHANTABILITY. FURTHER, TAPCO Inc. SHALL IN NO EVENT BE OBLIGATED FOR ANY INCIDENTAL OR CONSEQUENTIAL DAMAGES AS A RESULT OF ANY DEFECT OR ANY WARRANTY CLAIM, WHETHER EXPRESS OR IMPLIED. Some states do not allow exclusion or limitation of incidental or consequential damages or limitation on how long implied warranties last, so the above limitations and exclusions may not apply to you.

f. This warranty gives you specific legal rights, and you may also have other rights which vary from state to state.

g. TAPCO Inc. does not authorize any third party, including any dealer or authorized warranty service center to assume any liability of TAPCO Inc. or make any warranty for TAPCO Inc.

Warranty registration cards must be completed and mailed to TAPCO Inc. within 30 days of purchase.

FACTORY SERVICE

TAPCO Inc. has a staff of highly qualified service personnel who can assist with any field problems which may arise, and are able to answer questions concerning any aspect of the use and performance of our products. Our telephone number is (616) 695-6831. If you wish written information, replacement parts, or factory service, our address is:

TAPCO Inc.
3810 148th Ave. NE
Redmond, WA 98052

If you write the factory, please include a concise description of your problem, any related equipment, your phone number and the time of day when you can be reached.

FACTORY SERVICE ADDRESS

TAPCO Inc.
Service Department
3810 148th Ave. NE
Redmond WA 98052
(206) 881 9555



600 Cecil Street, Buchanan, Michigan 49107