

61PM

EV **Electro-Voice**[®]
POWER MIXER SERIES

OWNER'S MANUAL



TABLE OF CONTENTS

INTRODUCTION	3
SPECIFICATIONS	4
OPERATION	6
Block Diagram	(fold-out from Page 6)
APPLICATIONS	10
IN CASE OF DIFFICULTY	13
Troubleshooting	13
General Maintenance	14
Alternate Primary Wiring	14
Factory Service Information	14
PRIMARY WIRING CONFIGURATION CHART	15
REPLACEMENT PARTS LIST	16
SCHEMATIC DIAGRAM	(fold-in sheet)
WARRANTY	Inside rear cover

WARNING: TO REDUCE THE RISK OF FIRE OR ELECTRIC SHOCK, DO NOT EXPOSE THIS EQUIPMENT TO RAIN OR MOISTURE.

INTRODUCTION

Your Electro-Voice Power Mixer is a high-performance mixing console with an integrated 200-watt monaural amplifier. The Mixer is a reliable, all-in-one, compact, lightweight sound reinforcement system that is easy to set up and take down. It is designed to deliver enough power to accommodate a large hall, yet small enough to fit conveniently in a small lounge where space is at a premium. This makes it ideal for club musicians, church and gospel groups, high school auditoriums, or shopping mall setups.

Several of the Mixer's inputs and outputs have internal "patching" that automatically connects or disconnects signal lines whenever you plug in external equipment to save you time and reduce wiring congestion.

The Mixer incorporates a recessed front panel to protect the control knobs. All the input and output jacks are accessible from the front panel, with the exception of the power amplifier output jacks, (TO SPEAKERS), which are located on the rear panel.

SPECIFICATIONS

Amplifier Power Output	4 ohm load: 200-watts. 8 ohm load: 125-watts.
Frequency Response	Power Amplifier: 20 - 20 kHz ± 0.5 dB. Mixer: Microphone input to any output, EQ flat, gain controls nominal 20 Hz - 20 kHz ± 1 dB.
Total Harmonic Distortion	
Power Amplifier	< 0.5% @ maximum rated power with 4 Ω load, 20 Hz - 20 kHz. < 0.1% @ maximum rated power with 8 Ω load, 1 kHz.
Mixer	< 0.1% @ +20 dBu, 20 Hz - 20 kHz.
Noise*	-126 dBu EIN-equivalent input noise, microphone input. -90 dBu residual at main out (all gain controls @ minimum). -90 dBu residual at monitor out. -70 dBu residual at main and monitor; all input gain controls @ minimum, main and monitor @ 0 dB.
Input Channel Equalization	± 12 dB low cut/boost centered at 90 Hz. ± 12 dB high cut/boost centered at 10 kHz.
Channel Inserts	1/4" stereo phone plug, tip send, ring return.
Microphone Inputs	
Type	(low-impedance, balanced, pin-2 reference positive)
Maximum Input Level	+14 dBu (3.9 volts).
Input Impedance @ 1 kHz	4400 ohms.
Clip Indicator Threshold	+11 dBu (at minimum gain).

* 20 Hz - 20 kHz — 150 Ω input impedance

Line Inputs	High impedance, balanced, tip positive.
Maximum Input Level	+24 dBu (12-volts).
Input Impedance	30 k Ω .
Tape Inputs	High impedance, RCA jack, unbalanced, tip positive.
Input Impedance	100 k Ω .
Graphic Equalizer	9-band, Constant Range™; \pm 12 dB cut/boost. Center Frequencies: 50, 100, 200, 400, 800, 1600, 3150, 6300, 12,500 Hz.
Maximum Voltage Gain \pm 3 dB	75 dB — Mic In to Main Out. 60 dB — Line In to Main Out. 75 dB — Mic In to Monitor Out. 60 dB — Line In to Monitor Out. 87 dB — Mic In to EFX Send. 72 dB — Line In to EFX Send. 30 dB — Tape In to Main Out.
Crosstalk	-75 dB — Adjacent inputs: 1 kHz. -75 dB — Input to output: 1 kHz. -50 dB — All combinations: 20 Hz to 20 kHz.
Echo	Electronic, adjustable delay time.
Maximum Power Indicator	Lights when compression circuit is acti- vated.
Dimensions	17.4 H x 39.6 D x 45 W cm (6-7/8" x 15-1/2" x 17-3/4")
Weight	25 lbs (11.3 kg).
Power Requirements	100/120/220/240 VAC, 50/60 Hz.
Case	Rotomolded polyethylene with line cord storage area.

Specifications subject to change without notice.

OPERATION

CAUTION: Do not expose this unit to rain or moisture. If liquid should spill into the Mixer, have it cleaned and inspected by a qualified service technician before you attempt to operate it. A fire hazard or electrical shock condition could exist.

During the Operation, we will discuss each function of the Mixer so that you can become familiar with it before you attempt to use it. The "Applications" section that follows this description will show you how use the Mixer in a typical setup situation.

Each input channel of the Mixer is identical. Therefore, we will only discuss one of them.

Refer to the Block Diagram (fold-out from this page) and to Figure 2 (fold-out from page 9). The number at the beginning of each descriptive paragraph corresponds to one of the circled numbers in the Figure.

MAIN INPUT JACKS

The main channel signal input starts at the Line In and Mic input jacks. You can shape the signal with equalization, reverberation, or any other external special effects you wish to use. You can use the Mixer to drive a main speaker system using its internal 200-watt power amplifier, or to drive a separate power amplifier and monitor system. **NOTE:** Always use shielded cable when you connect any equipment to the Mixer inputs to reduce hum and noise.

The three main input jacks operate as follows:

1. **INSERT** jack — Allows you to add external signal processing equipment to one channel without disturbing any of the other channels. Use a ring-tip sleeve phone plug for both the output from the channel preamplifier, and the return to the Mixer's output stages from the external processing device.

Figure 1 shows you how to wire your own channel patching cord. You can also purchase the cord from most audio stores.

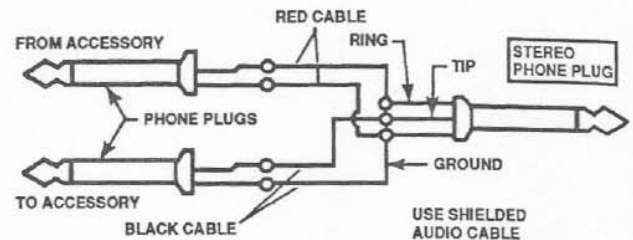

Figure 1

Use the insert jack with equipment such as a/an:

- A. Equalizer.
 - B. Limiter.
 - C. Compressor.
 - D. Chorus.
 - E. External reverberation device.
2. **LINE IN** jack — A balanced, high-impedance input which uses a standard 1/4" phone jack. It is also connected to the Mic input jack through isolation resistors so that you can use the two jacks simultaneously. The Line input can safely accept signals of up to +24 dBu, including a variety of audio signal sources, such as a/an:
 - A. Electronic keyboard or synthesizer.
 - B. Electronic drum machine.
 - C. Guitar.
 - D. CD player.
 - E. Turntable.
 3. **MIC** input — A balanced, low-impedance input that accepts signals from a microphone with a 3-pin XLR- or a Cannon-type connector. The Mic input is actively balanced to eliminate an input

transformer (and its limitations) while maintaining excellent RF and hum rejection. The Mic input will accept signals up to +14 dBu, including a/an:

- A. Balanced, low-impedance dynamic or ribbon microphone.
- B. Balanced, low-impedance condenser microphone.
- C. Balanced, low-impedance instrument output.
- D. Balanced, low-impedance microphone level source.

CONTROLS

4. **GAIN** — Adjusts the signal input level. It allows you to apply signals that cover a wide dynamic range without fear of overload. This adjustment is necessary due to the wide variations in signal strength presented by the different signal sources that are commonly used. This control allows you to set the gain of each channel to obtain the optimum signal-to-noise ratio and the lowest distortion and noise.
5. **EQUALIZATION** — Also referred to as "tone" controls since they adjust the high and low (treble and bass) frequency response of the signal. There are two equalization controls, which operate as follows:
 - A. **EQ HIGH** — Controls the treble content of the input signal. If you turn the control knob clockwise, the higher frequencies will increase; turn it counterclockwise to decrease them.
 - B. **EQ LOW** — Controls the bass content of the input signal. If you turn the control knob clockwise, the lower frequencies will increase; turn it counterclockwise to decrease them.

NOTE: Adjust the equalization controls for the most even sound response. Too much equalization using either control can distort the sound and make it too "tubby" or "shrill."

6. **MONITOR** — Sets the level of the monitor mix. The monitor channel is not affected by the EQ controls or by the Main channel slider control.

7. **EFX/REV** (effects/reverberation) — Adjusts the amount of input signal that is sent to the reverberation unit. Turn the control knob clockwise to send more signal to the reverberation unit and increase the "echo." Turn it counterclockwise to decrease the effect.
8. **CLIP LED** — Monitors the input channel for clipping or "overload" conditions, both before and after any equalization occurs. Whenever you notice a Clip LED starting to flash, it means that the signal is approaching distortion. Clipping may occur if you add too much equalization high, reduce the gain until the LED stops flashing, otherwise, reduce the equalization levels.
9. **FADER** — Adjusts the signal output level as it is fed to the subgroups. The control is calibrated in "dB" (decibels). You should normally set this control at the "0 dB" mark so you can use it as a "reference" point for all the other gain controls. Once you set all of the other Mixer controls to their optimum points, use the Fader control to "fine tune" the signal level.

SUBGROUP SECTION

10. **TAPE IN** — Connects to the outputs of a stereo tape deck. The L and R stereo input signals are summed to convert them to a single (monaural) channel output.
11. **MAIN OUT** — Contains the sum of all of the input channel information from the main mix. The Main Out is internally patched to the power amplifier.
12. **MONITOR OUT** — Contains the sum of the input channel information from the monitor mix, excluding any equalization you may be using in the main output. You can connect this signal output to an external monitor power amplifier and speaker system to send to a tape recorder.
13. **EFX SEND** — Contains the sum of all of the input channel effects and reverberation information. You can connect this signal to external effects devices such as a delay, reverberation, flanger, etc. You can add internal reverberation to both the main and monitor mixes by using the Rev to Main and Rev to Mon controls.

14. **EFX RETURN** — Returns the signal from the EFX device. Use this input jack as a stacking source, (mixing external signal source material with the Mixer-generated signals), or as an auxiliary input. You can adjust this signal with the EFX RETURN control.

NOTE: If you are using any effects devices that use a "blend" control, it is important that you set this control at its maximum (100%) output level to prevent overall volume changes when you vary the EFX RETURN input control.

15. **EQ IN** — Accepts line level signals from an external unit. When you insert a phone plug into this jack, the Mixer's 9-band equalizer input is disconnected from the main output jack and the external signal source is connected in its place.
16. **EQ OUT** — Contains the equalized signal from the 9-band equalizer that you can feed to external equipment (e.g., another power amplifier).
17. **POWER AMP IN** — When you connect a plug to this jack, you disconnect the power amplifier input from the equalizer output. You can also use this jack as a monitor amplifier.
18. **9-BAND GRAPHIC EQUALIZER** — Adjusts the overall audio input signal frequencies in 9-band segments (50, 100, 200, 400, 800, 1600, 3150, 6300, and 12,500 Hz). This equalizer is an extremely flexible and versatile set of tone controls. It can shape the response of the sound system to suit almost any location. You can boost or cut each equalizer frequency band by 12 dB. Be careful when you use it! You could distort your sound and damage your speakers if you use too much equalization.
19. **EFX SEND control** — Adjusts the level of signal at the EFX SEND output jack.
20. **EFX RETURN control** — Adjusts the level of the externally-generated effects signals included in the main mix.
21. **TAPE control** — Adjusts the level of the signal coming from the TAPE IN jacks.
22. **REVERBERATION (REV) controls** — Reverberation is the natural decay of sound in a closed space (e.g., a room). The reverberation section in the

Mixer obtains its input signal from the EFX/REV controls on the input channel. The following controls adjust the amount of reverberation at the indicated output jacks:

- A. **REV TO MAIN** — Adjusts the amount of signal from the internal reverberation to the main channel output jack (MAIN OUT). When you turn the control knob clockwise, you increase the amount of reverberation, while counterclockwise rotation decreases it.
 - B. **REV TO MON** — Adjusts the amount of reverberation signal to the MONITOR OUT. Clockwise rotation of the control knob increases the amount of reverberation and counterclockwise rotation decreases it.
 - C. **DELAY TIME** — Controls the interval between echoes of the reverberation signal. When you turn the control knob clockwise, you increase the amount of time between echoes, while counterclockwise rotation decreases it.
23. **MAIN control** — Adjusts the overall volume of the main output signal, which is a sum of the individual channel information.
 24. **MONITOR control** — Adjusts the overall volume of the monitor output signal, which is a sum of the individual channel MONITOR control information.
 25. **MAXIMUM POWER LED** — Indicates when the special "compression" circuitry is in effect to prevent overdriving of the power amplifier.
 26. **POWER LED** — Indicates when the unit is on.

AMPLIFIER AND GRAPHIC EQUALIZER (EQ) PATCHING CABLE

The power amplifier and 9-band graphic equalizer output jacks allow the amplifier and/or equalizer in the Mixer to feed their signal to external equipment. You can use these jacks to:

- A. Patch the graphic EQ output to an external amplifier(s).
- B. Separate the internal amplifier from the Mixer circuitry (monitor amplifier, etc.).

The equalizer output jack (EQ OUT) and the amplifier input jack (POWER AMP IN) require no patch cords for normal operation, since they are switched internally. You can patch the equalizer output jack without disrupting the signal flow to the internal power amplifier. The amplifier input jack interrupts the signal coming from the graphic EQ section (EQ OUT) when you plug a connector into it.

The signals at the equalizer output jack (EQ OUT) are line level (+4 dBu), and are strong enough to drive power amplifiers and other line level devices.

The power amplifier input jack requires line level signals (+10 dBu for amplifier clipping).

REAR PANEL

Refer to Figure 2A for the following section.

27. **TO SPEAKERS** — These output jacks are tied together and connect the power amplifier signal to your speaker system. The total impedance presented to the amplifier must be no lower than 4 Ω , regardless of the number of output jacks you use. Any of the following combinations whose total impedance is 4 Ω or more will work:

An 8 Ω speaker
 A 4 Ω speaker
 Two 8 Ω speakers
 Four 16 Ω speakers (two parallel pairs)

NOTE: If you operate the amplifier with a load lower than 4 Ω , you could damage the amplifier. Such damage will not be covered by the Warranty.

28. **POWER** switch — Switches AC power on and off.

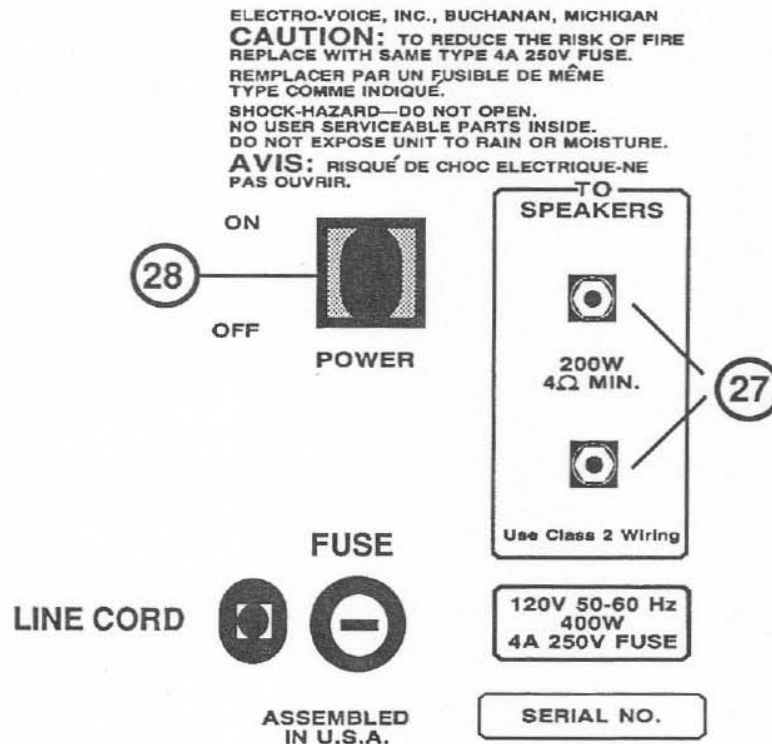

Figure 2A
 Rear Panel

APPLICATIONS

OPERATING PRECAUTIONS

IMPORTANT: If you damage the Mixer by disregarding any of the following precautions, the Warranty will not apply:

1. Do not expose the Mixer to rain or moisture. If you spill liquid inside the unit, have it cleaned and checked by a qualified service technician.
2. Do not operate the Mixer in an unventilated area. Leave enough space around the outside of the case for air to flow.
3. Do not operate speakers that are outside the rated impedance of the amplifier (refer to the "Specifications" on Page 4 for these ratings).
4. Do not operate the Mixer at an AC line voltage and frequency that is not within 10% of that selected by the power transformer (see "Primary Wiring Configuration" on Page 15).
5. Do not replace the line fuse with one that is higher than the proper size rated for your unit (see "Table 1" on Page 14).
6. Do not attempt to repair the Mixer without the necessary technical knowledge. Have it repaired only by an authorized service technician.

SETTING UP

Figure 3A (fold-out from this page) and Figure 3B (fold-out from page 13) show two typical hookups for your Mixer. Refer to each of these Figures as you read the following section.

Do not insert the Mixer's line cord plug into an AC outlet until you are instructed to do so.

All of the connections to the Mixer are made via the input jacks. In the following section, there are some considerations on how to connect a typical speaker system. Assume for now that you intend to connect only one speaker to the Mixer. You can connect more speakers if you wish. However, the total speaker impedance should be within the impedance range required by the power amplifier (between 4 and 16 ohms). Consider Point A.

- A. When you connect speakers to the TO SPEAKERS jacks on the Mixer's rear panel, you are connecting them in parallel (see Figure 4). For example, if you are using two Electro-Voice 100S speakers ($8\ \Omega$ each), the total impedance will equal $4\ \Omega$.

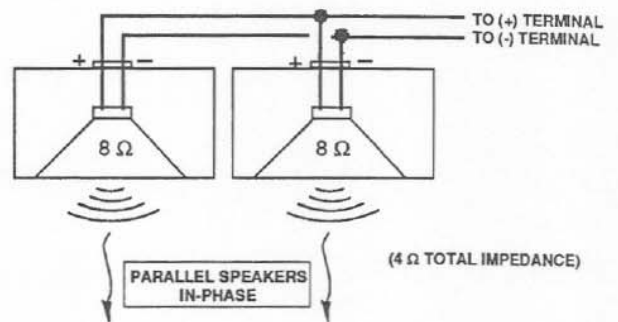

Figure 4

- B. Figure 5 shows a typical 2-conductor, 1/4" phone plug. Quality speaker cable has one lead marked so that you can be sure to connect each end of the same wire to the like terminals (e.g. marked wire ends to both positive terminals).

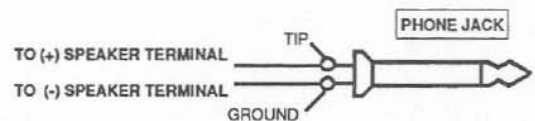
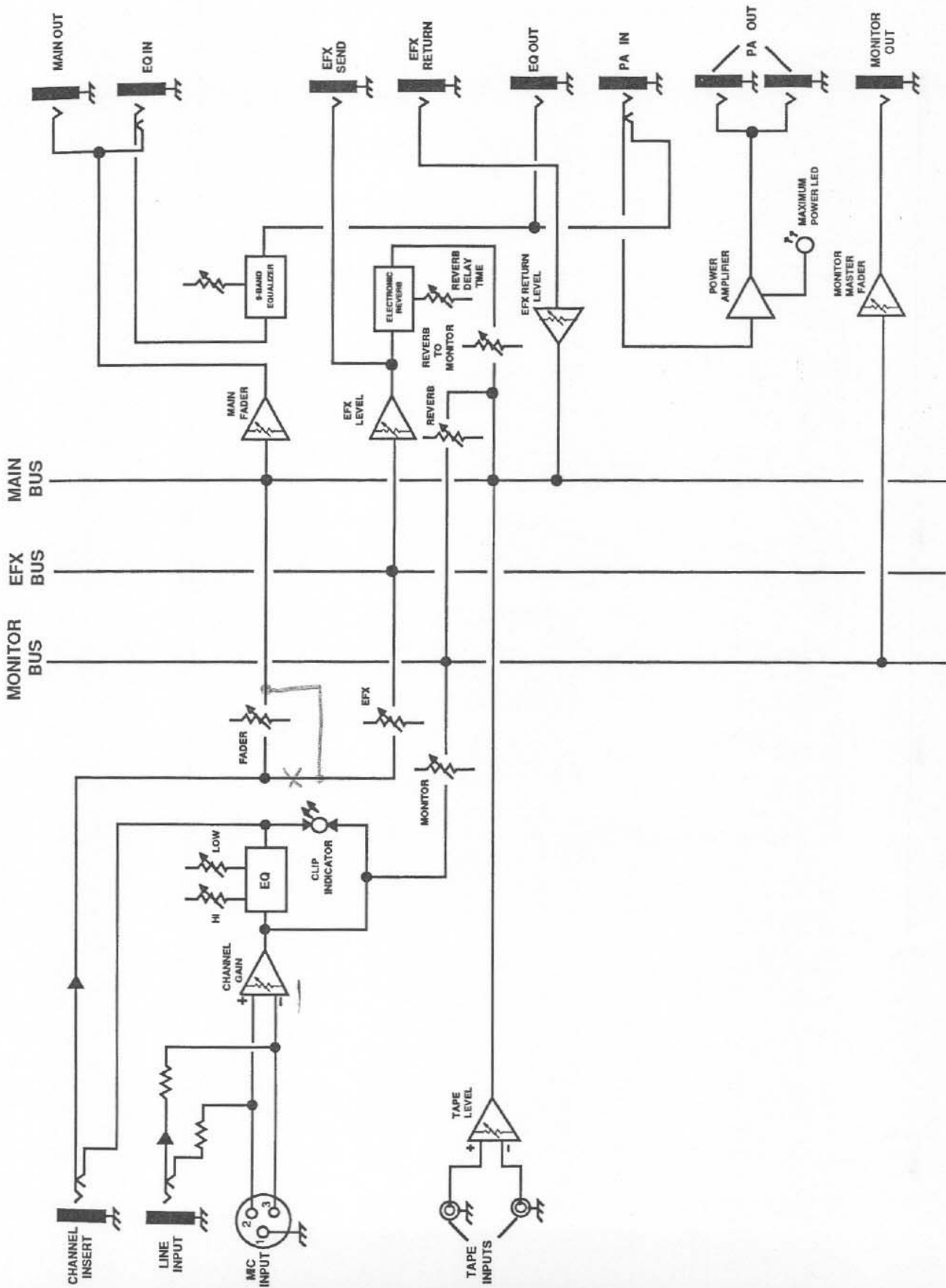

Figure 5

WARNING: Be careful when you assemble 1/4" phone plugs. It is easy to accidentally bridge the solder connections together or short them to the plugs metal sleeve. **If you use a shorted plug at the amplifier inputs, you could damage the power amplifier.**

- C. For most purposes, 18 gauge line "zip" cord works quite well for lengths up to 50 feet. For longer lengths, use heavier gauge wire. Table 1 on the following page shows the two-wire cable (copper) lengths permissible for a number of wire sizes and speaker impedances, to avoid a loss of more than 0.5 dB. For a 1 dB loss (basically imperceptible)



MIXER
BLOCK DIAGRAM

61 PM

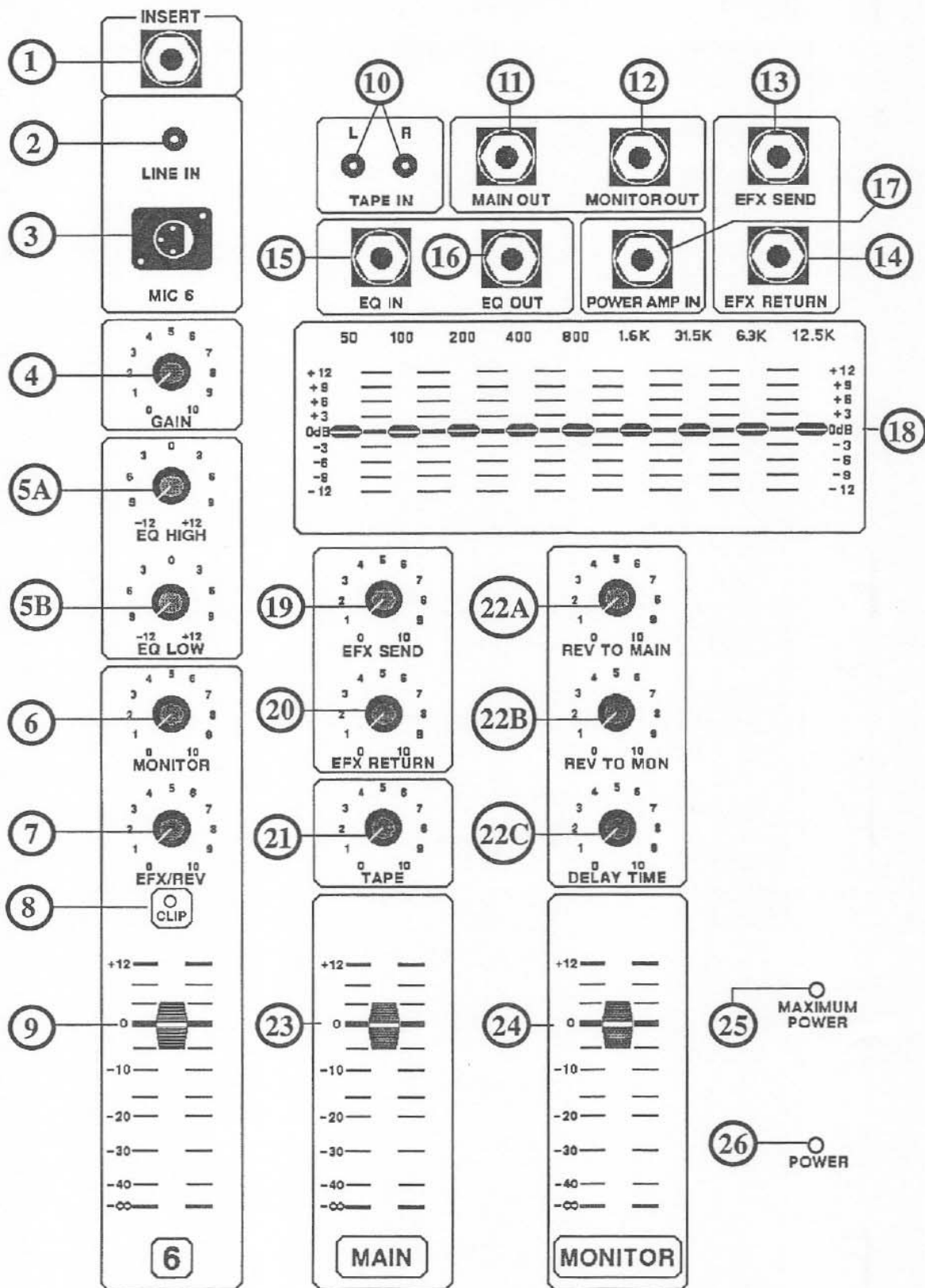
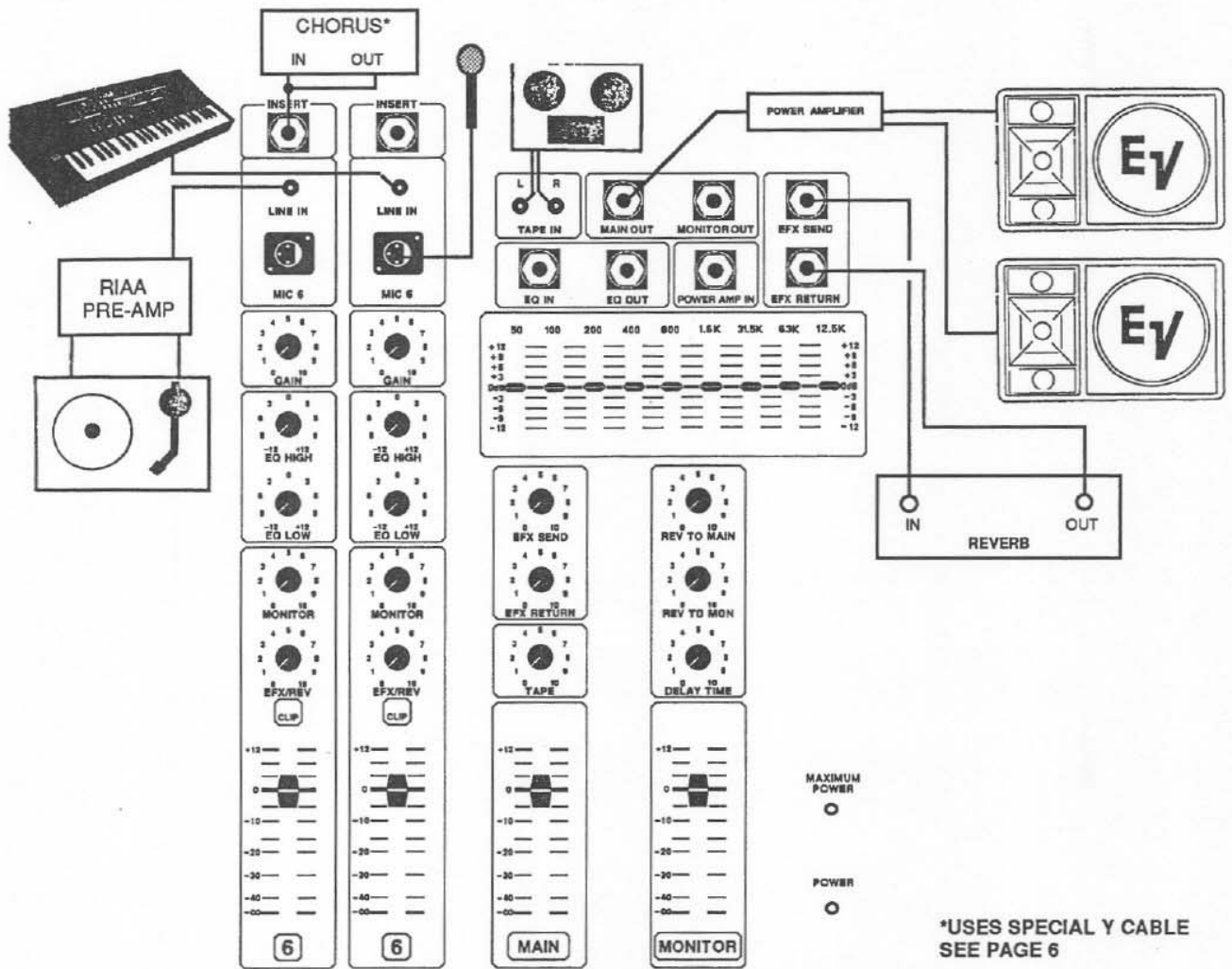

Figure 2



*USES SPECIAL Y CABLE
SEE PAGE 6

ELECTRO-VOICE, INC., BUCHANAN, MICHIGAN
CAUTION: TO REDUCE THE RISK OF FIRE
 REPLACE WITH SAME TYPE 4A 250V FUSE.
 REMPLACER PAR UN FUSIBLE DE MÊME
 TYPE COMME INDIQUÉ.
 SHOCK-HAZARD—DO NOT OPEN.
 NO USER SERVICEABLE PARTS INSIDE.
 DO NOT EXPOSE UNIT TO RAIN OR MOISTURE.
AVIS: RISQUÉ DE CHOC ÉLECTRIQUE-NE
 PAS OUVRIR.

REAR PANEL CONNECTIONS

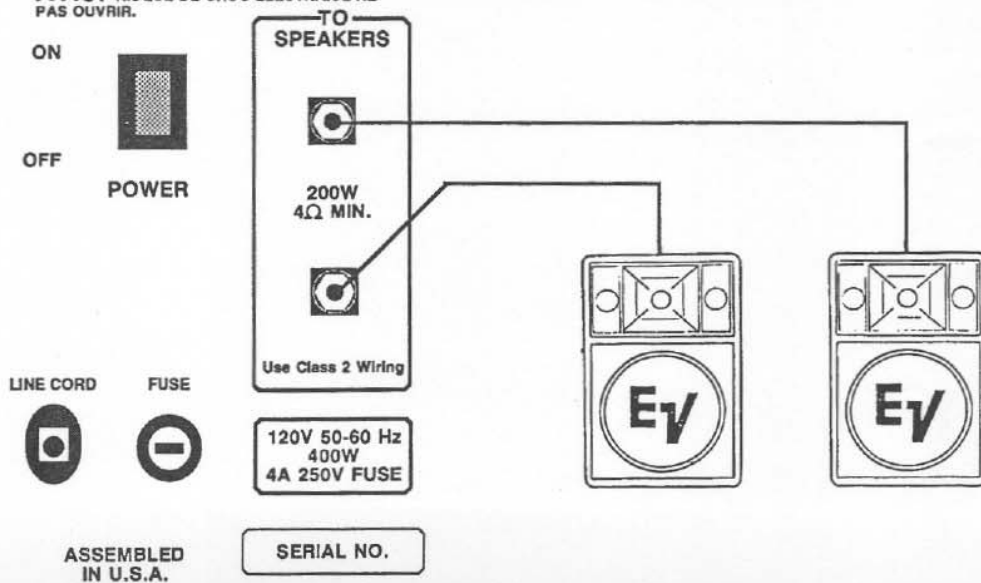
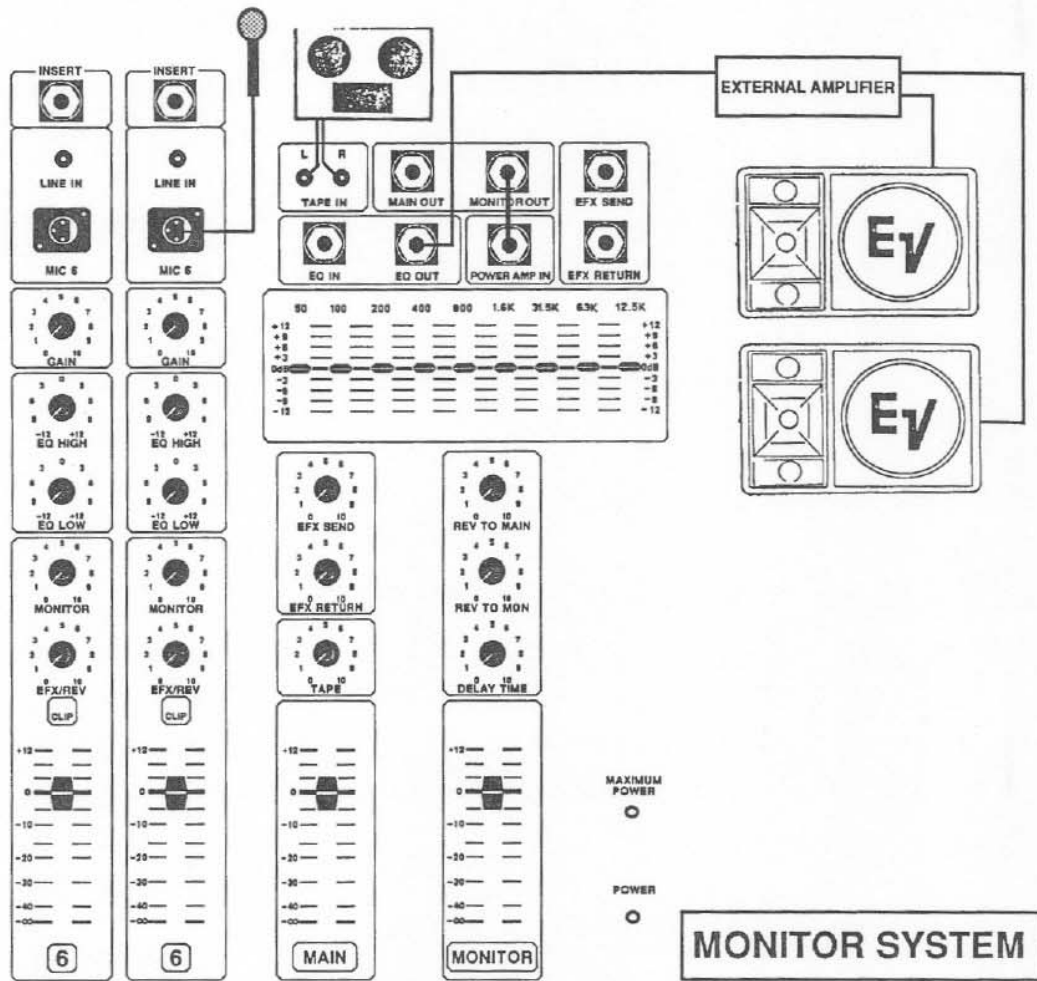

Figure 3A



ELECTRO-VOICE, INC., BUCHANAN, MICHIGAN
CAUTION: TO REDUCE THE RISK OF FIRE
 REPLACE WITH SAME TYPE 4A 250V FUSE.
 REMPLACER PAR UN FUSIBLE DE MÊME
 TYPE COMME INDIQUÉ.
 SHOCK-HAZARD—DO NOT OPEN.
 NO USER SERVICEABLE PARTS INSIDE.
 DO NOT EXPOSE UNIT TO RAIN OR MOISTURE.
AVIS: RISQUÉ DE CHOC ELECTRIQUE-NE
 PAS OUVRIR.

REAR PANEL CONNECTIONS

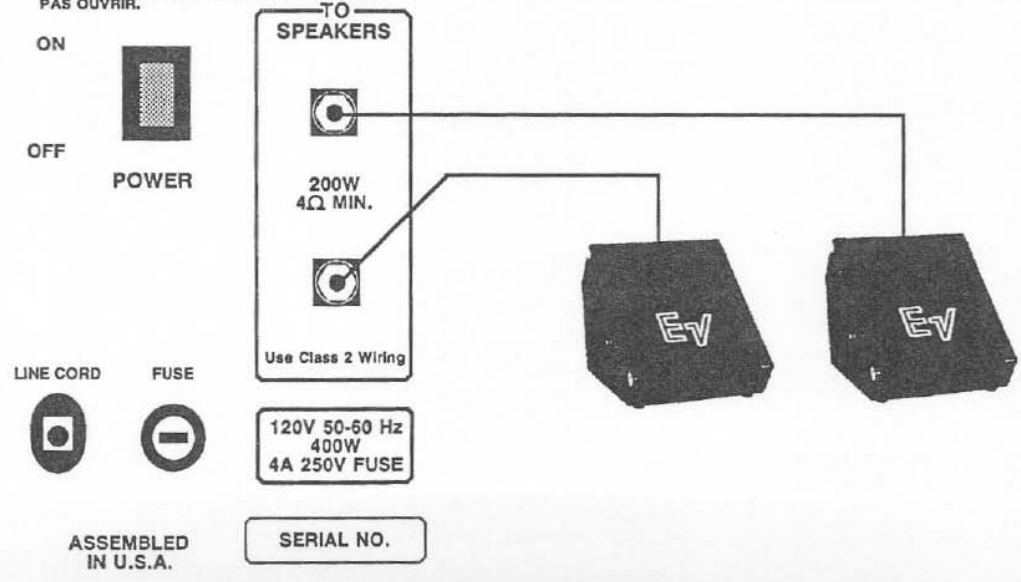

Figure 3B

AWG Size	Resistance (ohms/1000 feet)	Low-Impedance Systems			High Impedance Systems				
		4 Ω	8 Ω	16 Ω	200 W/100 V 100 W/70.7 V 12-1/2 W/25 V (50 Ω)	100 V/100 V 50 W/70.7 V 6-1/4 W/25 V (100 Ω)	50 W/100 V 25 W/70.7 V 3-1/8 W/25 V (200 Ω)	10 W/100 V 5W/70.7 V 5/8 W/25 V (4000 Ω)	2 W/100 V 1 W/70.7 V 1/8 W/25 V (5000 Ω)
10	1.00	120	240	480	1,500	3,000	6,000	30,000	150,000
12	1.59	75	150	300	940	1,900	3,800	19,000	94,000
14	2.50	48	96	190	600	1,200	2,400	12,000	60,000
16	4.02	30	60	120	370	750	1,500	7,500	37,000
18	6.39	19	38	75	230	470	940	4,700	23,000
20	10.1	12	24	48	150	300	590	3,000	15,000
22	16.2	7	15	30	93	190	370	1,900	9,300

Table 1

lengths may be doubled. For a 2 dB loss, multiply the lengths by 4.4. It is not necessary to use shielded cable for your speaker wiring since it is used at the output, not the input, where hum can be fed into the circuits. **Do not use coiled guitar-type cables for speaker connections. They are unreliable and waste amplifier power.**

- Assuming that your speaker cable is properly wired to the phone jack and speaker terminals, place the Mixer and speaker at their desired locations. Then connect the speaker phone plug to the Mixer's rear control panel at either TO SPEAKERS jack.
- Plug your microphone into the Mic 1 input. Remember that you can help minimize hum and buzz in the shielded input cables if you keep them separated from the power wiring.
- Plug stereo cassette or CD player line out cables into the Mixer's L and R Tape In jacks. Since the Mixer has a 200-watt monaural (mono) amplifier, the stereo tape signal will be summed (mixed together) by the Mixer's internal circuitry for mono output to your speakers. **CAUTION:** Never connect a tape deck to the amplifier output jack.
- Plug an external keyboard into the channel 1 Line In jack.
- Set the Gain control knob(s) to the 12 o'clock position.
- Set the High and Low EQ control knob(s) to their center (0) positions.
- Set the channel Fader slide control(s) to "0 dB."
- Set the 9-band equalizer controls to "0" and the Main fader at $-\infty$.
- Plug the Mixer's line cord plug into an appropriate AC outlet.
- Press the Off/On rocker switch in at the top to turn the Mixer on. The Power light should glow to indicate that power is applied to the circuits.
- Slowly slide the Main master control toward the +12 dB mark and speak normally into the microphone until you hear sound coming from the speaker. If you hear nothing from the speaker(s) when you reach the 0 dB mark, turn up the Gain control. If any of the Clip LEDs begin to flash, lower the Gain control(s) until they stay out. If feedback occurs (squealing in the speakers) before you reach a sufficient volume level:
 - Try carefully moving the speaker and microphone arrangement to obtain the most volume without feedback. Generally, this will cure most of the problem; or,
 - Use the graphic equalizer to minimize it. You can reduce acoustic feedback by lowering the equalizer slide control which covers the range where the feedback occurs.

Note the remaining externally-connected devices (synthesizer, chorus, digital reverberation, power amplifier, monitor system, etc.) shown in Figures 3A and 3B. If you have any of these devices, or similar ones, connect them to the indicated input/output jacks of the Mixer at this time.

12. If you have a tape deck connected to the Mixer, play a tape and advance the Tape control until you reach the desired sound level.
13. Once you have each channel set as in the previous step, you can use the Main master control to vary the overall sound level as desired. When the Mixer levels are set up properly with the sound output at its optimum, the fader controls should be around the same level.
14. Use the reverberation effect with discretion. Many rooms have their own natural reverberation characteristics. Too much reverberation can degrade your sound.
15. Use the 9-band graphic equalizer discreetly. You can easily shape the overall sound by adding or decreasing certain frequencies to warm or sharpen the tones. Avoid excessive boost in any one frequency range. It is easy to distort the sound in this manner or cause feedback. It is even possible to damage speakers by overdriving them. Try to keep the controls centered above or below the "0" line on the panel.

IN CASE OF DIFFICULTY

TROUBLESHOOTING

CAUTION: There are no user serviceable parts inside the Mixer. Do not attempt to remove the Mixer from its case. Lethal and near-lethal voltages are present inside the chassis. Refer all servicing only to authorized service personnel.

The problems listed below are typical ones that you could experience with your Power Mixer. Suggestions are also given that may help you locate the troubles. Usually, most problems you encounter are in the "common sense" category and easy to identify. Be systematic. To avoid confusion, make only one change at a time. Always check the obvious first. Here are a list of possible problems and some ways to correct them:

No Power to the Mixer.

1. Make sure that the Mixer is plugged into an AC outlet and that the outlet has the correct operating voltage. Also, if you use an extension cord, make sure that the cord is not defective. Plugs and sockets can wear out and become loose.
2. Make sure the Power switch is on. It is a rocker-type switch that you push in at the top to turn on.
3. Check the line fuse on the back panel of the Mixer. Unscrew the fuse cap and look at the fuse. If the element is open, replace it with the same type and rating as indicated on the back panel. If the fuse is open and you replace it, it may open again. If this occurs, unplug the line cord immediately and seek a qualified technician to find the problem. Remember, fuses that burn out when you turn the power on indicate a serious circuit problem. If you continue to replace fuses, or try to use a fuse with a higher-than-specified rating, you could further damage the circuitry and make a relatively inexpensive repair bill into a very large one.

Mixer operated normally, then turned off.

1. Check to make sure that the line cord plug did not accidentally become disconnected.
2. Check the outside of the case, especially the rear panel. If it is very warm, it is possible that the amplifier's thermal switch may have opened due to the heat. If this happens, turn the Power switch off and allow the unit to cool. Then turn it on once more and see if the condition is corrected. Make sure that you place the unit in a well-ventilated area.

Mixer's Power light glows, but there is no output from the amplifier.

1. Check the speaker connections. One of the cables may be loose, either at the speaker terminals or at the power amplifier output jack. Also check the wire connections inside the jack.
2. Make sure the speaker fuses have not opened (if you are using fuses).
3. The Power Amp In jack may have a connector inserted. If this happens, the internal power amplifier signal is interrupted.
4. Check the speaker cable wiring for shorted connections.

One of the Mixer channels is inoperative.

1. Use another input channel that you know is okay. If there is still no output, the device is the problem. If the unit works in the other input channel, check the Fader and Gain control for the dead channel. They may be all the way down.

Channel has a high hum or noise level.

1. Check the input cable for that channel. There may be a broken ground wire somewhere.

GENERAL MAINTENANCE

If you should encounter a slider control that is noisy, position the control at either end of its travel, and spray a small amount of contact cleaner into the slot at the center of the control. Work the cleaner over the contact areas by sliding it back and forth several times. If you do not have any contact cleaner, you can use a small amount of spray lubricant, such as WD-40®.

Clean the case and control panel face with a clean rag dampened with a mild detergent. Do not soak the rag since moisture could seep inside the unit and cause circuit damage and corrosion. After you wipe the surfaces with a damp rag, buff them briefly with a soft, dry cloth.

ALTERNATE PRIMARY WIRING

Any changes in the Mixer's power transformer wiring configuration should be made only by qualified service personnel. Hazardous AC voltages and currents are present inside the chassis. Do not attempt to service this unit unless you are qualified to do so.

The Mixer will safely operate over a specified range of AC line voltages. This safe operating range depends upon the configuration of the power transformer's primary wiring. The "Primary Wiring Configuration" chart on Page 15 shows the various possible primary winding configurations. The wiring connection points are made inside the Mixer at terminal block TB.

To reconfigure the power transformer's primary wiring, use the following procedure:

1. Press the Mixer's Power switch to the off position and disconnect the line cord plug from the AC outlet.
2. Remove the five top, six rear, and four bottom screws and carefully remove the unit from the case.
3. Locate the voltage selection terminal blocks that are mounted near the power switch.

4. The power transformer has six primary leads. The lead colors are: black, red, orange, yellow, blue, and white. Disconnect the leads by pulling them straight out until the connectors disengage.
5. Select the desired operating voltage from the "Primary Wiring Configuration" on Page 15 and re-connect the primary transformer leads accordingly. Push each lead connector into the terminal block firmly until it locks into place. You should hear a faint latching "click" when this happens.
6. Refer to Table 2 and install the correct line fuse.

Table 2

LINE VOLTAGE CONFIGURATION	LINE FUSE (Normal-Blo)
100 V	4 A/250 V
120 V	4 A/250 V
200 V	2 A/250 V
220 V	2 A/250 V
240 V	2 A/250 V

7. Reinstall the Mixer chassis in the case and secure it with the screws you removed earlier.

FACTORY SERVICE INFORMATION

The Electro-Voice service personnel are highly-qualified to assist you with any field problem you may encounter. They can answer questions concerning any aspect of the use and performance of their products. If you have any questions or need our assistance during normal business hours, call us at one of the numbers listed below. If you need written information from our factory service personnel, please include a concise description of your problem, any related equipment you are using, your phone number, and the time of day when you can be reached.

Our Factory Service address is:

Electro-Voice, Inc.
 Service Department
 3810 148th Avenue, N.E.
 Redmond, WA 98052
 (206) 881-9555

PRIMARY WIRING CONFIGURATION

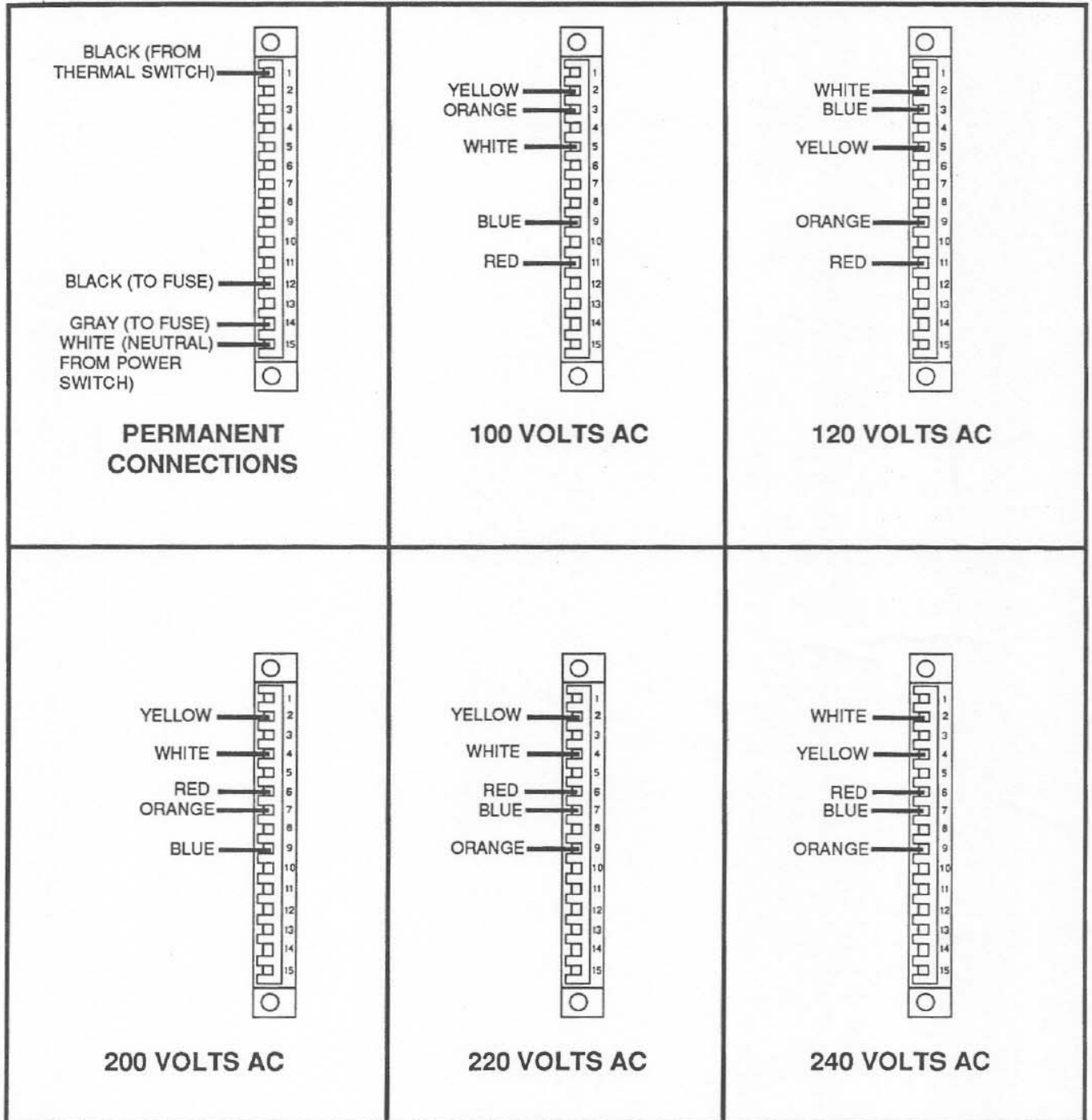

REPLACEMENT PARTS LIST

INTEGRATED CIRCUITS (ICs) & TRANSISTORS

<u>No.</u>	<u>Description</u>	<u>Part No.</u>
1	BUCKET BRIGADE DEVICE	MN 3008
2	COMPANDER	NE 570
3	DUAL D FLIP FLOP	GD 4013B
4	OP AMP	NE 5532D
5	OP AMP	TA 75558P
6	OP AMP	TLC 072D
7	TIMER	TLC 555
8	TRANSISTOR	IRF 630
9	TRANSISTOR	IRF 9642
10	TRANSISTOR	KTA 970
11	TRANSISTOR	KTA 1015
12	TRANSISTOR	KTB 834
13	TRANSISTOR	KTC 1815
14	TRANSISTOR	KTC 2240
15	TRANSISTOR	KTD 880
16	TRANSISTOR	2SA 965
17	TRANSISTOR	2SA 968
18	TRANSISTOR	2SC 2235
19	TRANSISTOR	2SC 2238
20	TRANSISTOR	2SD 1111
	Main out pot	47-06-037227; 200KB



600 Cecil Street, Buchanan, Michigan 49107, Phone (616)696-6831, TWX: 810-270-3135

8234 Doe Avenue, Visalia, California 93291, Phone (209)651-7777, TLX 172 119

Electro-Voice Div., 345 Herbert St., Gananoque, Ontario, Canada K7G 2V1, Phone (613)382-2141, TLX 389 066 3245

Electro-Voice, S.A., Kellenstrasse 5, CH-2563 IPSACH, Switzerland, Phone (41)32-51-68-33, TLX 845 934 045, FAX (41)32-51-12-21

Electro-Voice, Ltd., 2-5-60 Izumi, Suginami-ku, Tokyo, Japan 168, Phone (81)3-325-7900, TLX 781 232 2494

Electro-Voice Germany, Larchenstrasse 99, 6230 Frankfurt/Main 80, Germany, Phone (49)69-380-100, TLX 841 413 847

Electro-Voice Pty, Ltd., 59 Waratah Street, Kirrawee, N.S.W. 2232, Australia, Phone (61)2-521-5322, TLX 790 267 93