

EY TAPCO

C-12

**SERIES
TWO**

C-8E

OWNER'S MANUAL

a **gulton** company

TABLE OF CONTENTS

INPUT SECTION CONTROLS and CONNECTORS	2
OUTPUT SECTION CONTROLS and CONNECTORS	5
SUBGROUPING	7
PATCHING CONNECTORS and DIRECT OUTPUTS	8
INPUTS and OUTPUTS, SIGNAL LEVELS	9
STEREO and MONO	11
PHANTOM POWER	11
STANDARD PATCHES and BOARD SETUP	13
Mono PA	14
Effects	15
More Effects	15
More Monitor Mixes	16
SIMULTANEOUS PA and RECORDING	16
STEREO PA	18
MONITOR and AUX BUS	
Using the Monitor and Aux busses for stereo recording	19
RECORDING PATCHES	20
C8-E EXPANDER	26
C-12 SERIES TWO system block diagram	29
SPECIFICATIONS	30
OPTIONS	31
Appendix	
Of Long Lines and Mixers	32
Related Books and Magazines	37

INTRODUCTION

The C-12/Series Two Mixing System is a uniquely inter-related system of products that can be combined to develop complete system capability. This modular approach, an extension of the Tapco-pioneered expander concept, lets you buy only the specific functions needed for any given job. The C-12/Series Two products provide a level of performance and flexibility that is simply not available anywhere else for less than an arm and a leg.

Because the C-12/Series Two is the product of experience it is deceptively simple, well thought out, and extremely versatile. The 12 x 4 x 2 x 1 format, the double-duty solo system, the stereo compatible sub-grouping, multi-function metering, and the extensive patching facilities are all features pioneered by these products. On the surface these features are definitely self-explanatory, but there's another level of understanding lurking behind the obvious. It's to that other, higher understanding, that this manual is dedicated.

We know it won't take you very long to figure out how the system goes together, and how the various controls work. So, we know you won't even bother reading the owner's manual just for that. But there's that other level, those subtleties you don't even become aware of until you've tried every patch imaginable. That's the level we're hoping you'll get into faster with the help of this manual.

We don't pretend to know all the answers for your particular situation. But we do know exactly how signals flow through the C-12/Series Two products, and we do have an easy way to transfer that information to you. Sure, we'll show you the standard patches you'd use for those common situations, and a few of the non-standard patches we've discovered in our field testing programs. However, we're not out to tell you exactly what to do with the mixer, but rather give you the information you need to know how to do whatever you want.

The C-12/Series Two is specifically designed to do more than meets the naked eye. Let this manual serve as your microscope that you may see through the panel, behind the knobs, into the systems that give it such versatility. We really hope that some inkling of the C-12's true adaptability is one of the reasons you bought it in the first place, so we're doubly hopeful you'll take the time to get what you need from this manual. End of pitch, OK?

Input Section

Mic Input – Rear of Unit

A standard 3-pin XLR connector for balanced low impedance Microphone Inputs is provided.

Line Input – Rear of Unit

A standard 1/4" phone jack is provided for line level signals. Minimum input level to set a nominal channel send level of 0dBu is 77mV rms, or -20dBu. The input impedance is 20k ohms.

Channel Patching

Convenient 1/4" phone jacks are used to insert external processing gear in an individual channel, and/or for direct outputs.

Send/Return insert points are before the channel fader and after the channel EQ.

Channel Outputs

This 1/4" phone jack provides a post-EQ and post-fader signal for a direct send for multi-track recording, as an individual cue or effects send, or for a patch to another point in the mixer.

Mic/Line Switch

Allows you to select either a line level input (switch "in"), or balanced microphone input (switch "out").

Clip Indicator, Trim Control

Trim adjusts gain of first preamp stage in input channel, for both Mic and Line inputs. Clip (Peak) indicator LED lights when an overload condition occurs, in either the first stage or in EQ and fader stage.

Monitor

Monitor Control is a *pre-fader, pre-EQ* send that provides a separate mix for monitoring, or an independent bus send.

Aux

AUX Control is designed to be used either *pre-* or *post-fader* and EQ to provide an additional mix for monitors, cue, effects, reverb, etc.

Effects

Effects Control is a *post-fader, post-EQ* send most often used in conjunction with the Effects Return in the output section to provide a mix for external effects devices.

Equalization Controls

Frequencies of 3-Band EQ section have been selected for widest range of musical equalization. There are ± 18 dB shelving-type bass (50Hz) and treble (15kHz) controls, and an adjustable-frequency midrange control (± 12 dB peak/dip-type). Midrange sweep control can set frequency to be equalized anywhere from 300Hz to 6kHz. Three EQ controls have a center-detent with grounded center taps, so equalizers are totally out of circuit when centered.

Sub (Channel) Assign Switches

Sub Assign Switches route the signals from the input channels directly to sub-groups 1, 2, 3, or 4. Any input channel may be fed to any or all sub-masters by using the proper switch or combination of switches.

Stereo (Mains) Assign Switch

Routes any input signal directly to the L/R Stereo Master bypassing the sub-groups, and may be used simultaneously with the Sub Assigns for live recording, etc.

Pan Pot

Positions the input channel signal between any odd-even combination of sub-groups or within the stereo panorama between the L/R stereo outputs.

Mute

Allows muting of post-fader functions of input channel including channel output, aux (post) output, effects output, sub-assign, and L/R stereo assign. Does not affect pre-fader or solo functions.

Solo

When depressed, allows *post-fader* monitoring of the input channel. It pre-empts headphone monitoring with the individually selected signal(s).

Channel Fader

Active channel level control (100mm travel) adjusts volume of channel in overall mix. AutoPad™ circuitry maximizes headroom and S/N ratio while providing the same kind of smooth acting taper and overall attenuation as a passive fader.

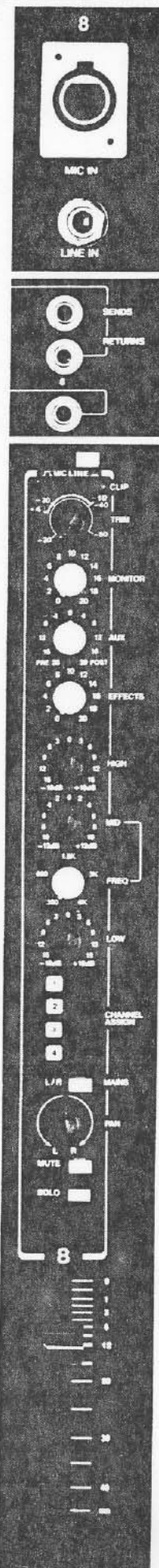

INPUT SECTION CONTROLS, CONNECTORS

LINE INPUT

A standard $\frac{1}{4}$ " phone jack for Line level signals (from tape machine outputs, other mixers, etc.). All input channel controls, including the variable gain Trim control, affect the Line Input. Maximum input level before preamp clipping is 25 Vrms or +30 dBu. Minimum input level to set a nominal Channel Send level of 0dBu is 77.5 mVrms, or -20 dBu. The input impedance is 20 k Ohms.

MIC INPUT

A 3-pin XLR connector for balanced low impedance Microphone Inputs. Pin 3 is "hot." The Mic Input is transformer coupled, with +48 V Phantom powering available via the transformer's center tap. Maximum input level is 1 V; or 0 dBV. Phantom powering applies +48V dc to pins 2 and 3.

CHANNEL PATCHING, OUTPUTS

These connectors are used for the insertion of specialized external processing gear in an individual channel, and/or for direct outputs. The Send and Return jacks are normalled, so the signal path will not be interrupted unless a plug is inserted in the Return jack.

The Send/Return insert point is right after the first stage preamp, allowing external processing to be done before signals pass through the channel's EQ and fader. Patching at this point in the circuit is unusual, and offers a few operational advantages. The EQ circuitry is available to help compensate for noisy external equipment, and to help bring out the best of certain effects, such as phasing. Compressors, limiters, noise gates and the like may be pre-set, because changes in the channel's EQ and fader settings will not change the levels seen at the Send jack. And, in a pinch, the Return jack can be used as a channel input without losing the use of the EQ and fader. Only the Trim control is obviated when this is done.

The Direct Out jack comes after the EQ and fader so it can be easily used for a direct send to a multi-track recorder, as an individual cue or effects send, or for a patch to another point in the mixer.

Impedance at the Send and Direct Out jacks is 68 Ohms, minimum load 600 Ohms. Maximum output drive is 6.2 Vrms, or +18 dBm, maximum return level is 8.7 Vrms, or +21 dBu.

CLIP INDICATOR, TRIM CONTROL

Trim adjusts the gain of the first preamp stage in the input channel, for both the Mic and Line inputs. The Clip indicator LED lights when an overload condition occurs, in either the first stage or in the EQ and fader stage.

The Trim control is used to match the gain of the first preamp stage to the signal strength of the source being run through the channel. To get the cleanest, quietest operation from the board it's important that the Trim control be properly set. To set up a mix, first put all the input and sub-group slide faders at "12." Then adjust the Trim controls for a rough mix, and do the fine tuning with EQ and faders as necessary. Whenever possible it's best to try to maintain that "straight line" relationship between all the faders. When this is done all the levels within the console are very close to being optimized for the best noise and distortion performance. Of course it's not always possible to adjust the Trim controls during a mix because they cause the levels at the Monitor, pre-Aux and channel patch point to change as well.

There's no real harm in having a widely varying set of levels on the sliders, unless the Clip indicator is being lighted. The sensing circuitry for the Clip LED monitors levels after both the first stage preamp, and the EQ and fader stages. So, signals that are set up as described above, then boosted with either lots of EQ or drastic level increases at the fader, may cause the LED to flash even though the first stage is OK. In any case, reducing the overall gain with the Trim control will almost always eliminate the overload condition. If not, it may be necessary to use an external pad to reduce levels before they enter the channel.

MONITOR

The Monitor control is a pre-fader (and EQ) send used to provide a separate mix for stage monitoring, headphone cue, or what have you. The Monitor send is not affected by the action of any of the controls on its respective channel except Trim, and the Mic/Line switch. The Monitor send signal is derived before all other controls, so the stage monitors or headphones do not need constant attention.

AUX

The Aux control can be used either pre or post fader to provide an additional mix for monitors, cue, effects, reverb, etc.

The Aux bus can get its signals from two points in the input channel -- one point is just after the first stage like the Monitor send, and the other just after the channel fader, like the Effects send.

The Aux send control is off in the center of its rotation (the pot has a center detent). To the right, clockwise, the signal is drawn from the post-fader point. To the left, or counter-clockwise, the signals are drawn from the pre-fader point in the circuit. This dual purpose pot arrangement saves us a switch on each channel without depriving the board of a very necessary and useful function.

The Aux controls may be used in any combination of pre and post sends simultaneously, on as many channels as the situation requires.

EFFECTS

The Effects control is a post-fader send most often used in conjunction with the Effects Returns in the output section to provide a mix for external effects devices. Because it is usually desirable to maintain a specific straight-signal to effects ratio for any fader setting, the Effects send is derived after the channel fader.

EQUALIZATION CONTROLS

The EQ section consists of ± 18 dB shelving type bass and treble controls, and an adjustable frequency ± 12 dB peak/dip type midrange control. All of the EQ controls (except the frequency selector, of course) have grounded center taps, so the equalizers are totally out of the circuit when the controls are centered (the pots have center detents).

The midrange frequency to be equalized may be set anywhere from 300 Hz to 6 kHz. You can see that at the extremes of its range the bass and treble curves are overlapped by the midrange giving rise to some very interesting EQ possibilities for some of those difficult situations.

CHANNEL ASSIGN, PAN POT

The channel assignment system consists of five push button switches located just above the pan pot. There are 4 buttons marked 1 through 4 and one marked L-R. The pan pot always works in an odd/even fashion with these switches.

By pushing only one of these switches, you assign that channel to the like numbered submaster. The panpot will have no effect.

If you push one odd numbered and one even numbered switch at the same time, you will assign the output of the channel to both selected submasters, and the panpot will pan the signal between the two submasters selected. Odd numbered submasters will be on the left side of the panpot and even numbered submasters will be on the right.

If you push two switches, both odd or both even, you will assign to those submasters. The panpot will have no effect.

If you push three or four switches, the panpot will pan between the odd numbered and even numbered switches.

The L-R assign switch located below the four submaster assign switches allows the input channel to be routed directly to the stereo master. This bypasses the four submasters and allows you to set up 4 mono subgroups on the submasters and 1 stereo group directly on the stereo master.

The L-R switch may be depressed simultaneously with the submaster assign switches. This allows you to do a stereo mix for PA with a simultaneous 4 track recording feed, with the recording feed being totally separate and isolated from the PA feed.

Output Section

Monitor Master Control

Sets overall output level of signals derived from the input channel monitor sends.

Monitor Solo Switch

Allows monitor bus signals to be soloed through the headphone solo system.

Aux Master Control

Sets overall output level of signals derived from the input channel aux sends. Can be used for additional monitor mix, effects, or independent feed.

Aux Solo Switch

Allows aux bus to be soloed.

Effects Master Control

Sets overall level of signals derived from the input channel effects sends.

Effect Solo Switch

Allows effects bus to be soloed.

Meter Switching

Allows switching of signals to each pair of meters. Meters 1 & 2 can be switched to monitor Sub 1 & 2, or the solo and mono outputs. Meters 3 & 4 can be switched to monitor Sub 3 & 4 or the L and R stereo outputs.

Solo Level Control

Sets overall level of solo bus signals heard on headphones and/or the main mix. At the CAL. mark, solo bus levels are referenced to "0" Vu so internal operating levels may be observed on all input channels, sub, and send masters.

Solo Status Led

Indicator lights to conveniently show when any of the solo switches have been engaged.

Solo to L/R Stereo (Mains) Switch

Routes all solo bus signals to the L/R stereo outputs. Used for P.A. sound checks, studio monitor routing, etc.

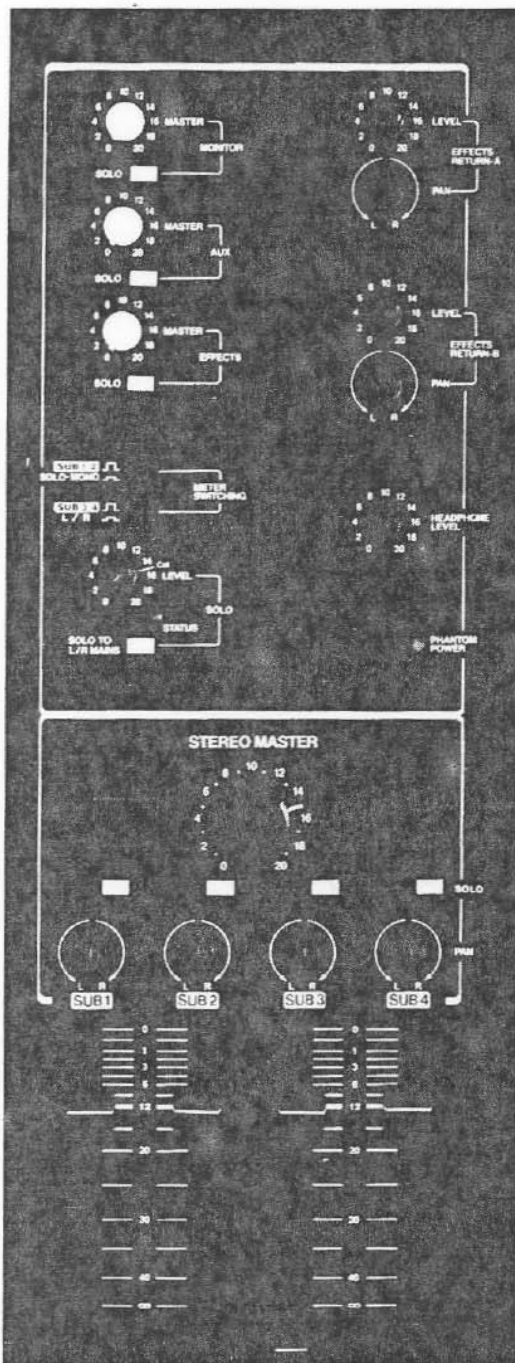

Effects Return-A, Level Control

Sets volume level in L/R stereo mix of all signals fed to the corresponding input jack on rear of unit.

Effects Return-A, Pan Control

Places the effects return A signal within the stereo panorama.

Effects Return-B, Level Control

Sets volume level in L/R stereo mix of all signals fed to the corresponding input jack on rear of unit.

Effects Return-B, Pan Control

Places the effects return B signal within the stereo panorama.

Headphone Level Control

This control adjusts headphone level from off to painfully loud when used with headphones from 8 Ohms to 2k Ohms impedance.

Phantom Power Led

Indicates activation of the +48V Phantom Power supply.

Stereo Master Control

Controls overall output level of the L/R stereo (mains) mix and the mono mix.

Sub Section

Solo Switches (Sub)

Allows the corresponding sub-group output signal to be soloed through the headphone solo system.

Pan Controls (Sub)

Each control places the corresponding sub-group output signal within the stereo panorama of the L/R stereo master.

Sub Level Controls

The four sub-group level controls determine the overall volume of their respective group. The 100mm slide fader controls are active instead of passive, so the lowest noise and best headroom performance are preserved throughout the system.

MUTE

The mute switch is located just above the solo switch. It is the input channel and post fader sends on/off switch. Its position in the signal path is just before the panpot/assign switches. It affects ALL post fader sends (effects and post aux). The monitor send is unaffected as well as the pre aux send. A channel may still be soloed while muted. Effectively, this gives a 'pre fade listen' (PFL). (The fader must still be up but since the channel is muted, the audience hears nothing). The mute switch does not affect the operation of the input channel overload LED.

CHANNEL FADER

The slide fader controls the output level of the channel as it's fed to the sub-groups. The fader system used here is not the usual loss causing potentiometer, but rather an AutoPad type active level control that preserves headroom and noise performance. The control is designed to operate the same way a fader-fader would, and should be normalized at the "12" mark. With all controls set to their designated normalized operating points, all circuits in the board are optimized from both noise and distortion standpoints. In other words, the signal levels are high enough to keep noise from creeping in and low enough to insure plenty of headroom and freedom from slew-induced distortion. If the fader must run wide open to get enough level, turn up the Trim control. Conversely, if the fader must be pulled way back to get the right level, the Trim control should be turned down. For optimum performance the channel faders should always be run as close to the "12" mark as possible.

OUTPUT SECTION CONTROLS, CONNECTORS SUB-GROUPS

The four sub-group level controls determine the overall loudness of their respective group. As with the channel faders, the control system used here is active instead of passive, so the best noise performance and headroom are preserved throughout the system. The sub-group level controls are normalized at the "12" mark, and should be run as close to that as possible.

Each sub-group is routed to several different places in the console. Each has a pair of patching connectors that includes a normalled Send, and an interrupting Return jack. From the Return jack the signals are routed to the left and right stereo buses via the Submaster pan control. The sub-groups also feed the headphone amplifiers in the same manner.

Operating levels within each sub-group are indicated on the VU meters, with 0 VU corresponding to 0 dBu at the sub-group Send. Since the Sends are post fader, levels will always reflect the fader setting.

SUBMASTER PAN

Each submaster has a panpot to allow the submaster output to be panned between the left and right stereo outputs. The panpot follows the submaster send and return jacks in the signal path. It is important to remember that the panpot does not create stereo, but merely allows you to place that source in the stereo field. Refer to the section on stereo and mono for more information.

Meter Bridge

The four illuminated level indicators are mounted above the main console surface and are angled for easy operator viewing. Each indicator is a high quality, full-wave, average responding meter, closely conforming to ANSI standards for VU indicators. More than twenty signals can be sampled and displayed on these meters using the appropriate function switches (see Meter Switching under Output Section).

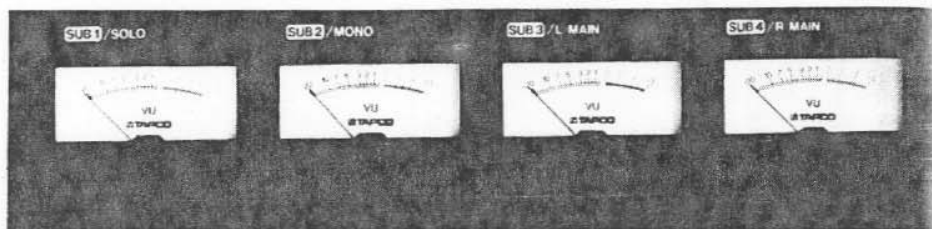

Rear Panel

Stacking Inputs

1/4" phone jacks are conveniently provided for connecting monitor, aux, effects, solo (control and audio), sub-group outputs, and left and right stereo buses from another mixer for "master/slave" operation. These jacks also provide an additional line input to the corresponding bus for cross patching or effects returns.

Outputs

1/4" phone jacks for monitor, aux, high level effects send, low level effects send, mono, and right stereo outputs.

Effects Returns

1/4" phone jacks will accept a wide range of signals, from guitar level to line level effects signals. Both Returns A & B have a hi and lo level input jack.

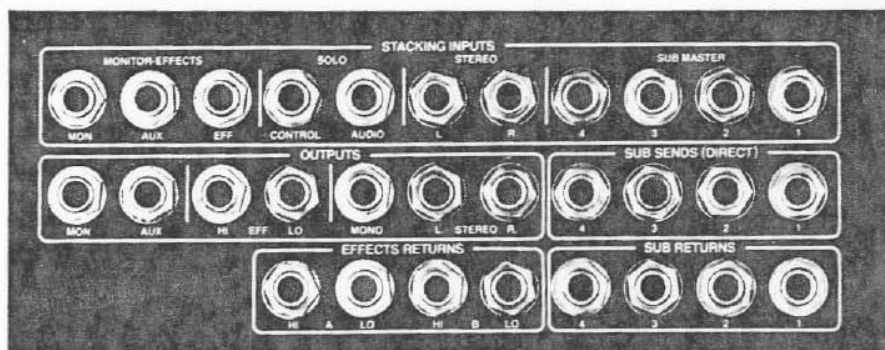

Sub Group Sends (Direct) and Returns

The four 1/4" phone jacks provided can be used for sub-group patching (effects, EQ, limiting, etc.), when used in conjunction with the four 1/4" return jacks. Used alone, they provide a direct output from each of the sub-groups. The returns are normalled to the send jacks and feed the pan pots at each of the sub-groups. Inserting a plug into the returns breaks the normal.

SUBMASTER SOLO

Each of the submasters has a solo switch. This locking switch allows you to monitor each submaster individually or in any combination with any of the other solo switches. The submaster solo is post fade and mono; that is it does not follow the panpot placement.

STEREO MASTER

This control sets the level at the left and right main outputs, and at the mono output, simultaneously. It does not affect the headphone amplifier. The heavy line on the panel under the stereo master indicates its normalized gain setting, because it is also an active level control. However, at this point in the circuit it is not as important to operate the stereo master at this level, even though performance will be optimized in so doing. In practice it will often be necessary to run the stereo master at some lower setting to keep from overdriving the next device in the signal chain. Because smooth, musical sounding fades are very difficult with linear faders, the Stereo Master is a rotary type pot.

Operating levels at the stereo outputs are indicated by the righthand pair of meters, and the mono output level is indicated by meter number two, when selected.

SOLO

The Solo Level control determines the loudness of the signals heard when any Solo button is depressed. Use the control to set a comfortable level for solo listening.

In addition to its usual solo listening function, the solo bus may be used to observe levels at any of the 19 points in the C-12 that may be soloed. In order to reference those levels to some standard, the Solo Level control must be set at the 'Cal.' mark. When this is done, and solo levels are observed on meter number 1, normal operating levels (OVU) will be seen if all the controls on the input channel, or in the particular bus that's soloed, are being run in their proper operating range. If something's amiss, levels shown by the meter will be either too high or too low, as the case may be.

The Solo to L/R Stereo switch allows the Main Outputs to be interrupted by the Solo system. When this switch is depressed both the headphones and the main outputs will follow the solo system. Otherwise, only the headphone signals are interrupted by the activation of the solo system.

The Solo Status indicator is lighted whenever a Solo button is depressed. Because the Solo buttons are all locking type switches (so you can have both hands free while soloing something), a red LED indicates that the solo system has taken priority over normal signals.

METER ASSIGN

The meter assignment switches are found in the output section of the C-12. There are two switches. Each switch allows you to reassign a pair of the 4 meters to another function.

The top switch changes meters 1 and 2 from reading submasters 1 and 2 to reading solo and mono.

The bottom switch changes meters 3 and 4 from reading submasters 3 and 4 to reading the left and right stereo outputs.

The meters are calibrated to read 0 VU at 0dBu for submaster outputs and 4dBu for L,R and Mono. *See the solo section for more information on the solo metering function.

HEADPHONE LEVEL

This control affects only the level of the Headphone Output signals. It will usually be operated between 9 and 12 o'clock because there's plenty of extra gain to help you find those very weak, "lost" signals.

USE OF SUB-GROUPS

The sub-groups are used to divide the mix into smaller, more manageable parts. These parts are then mixed, as groups rather than as individual inputs, to form the final composite mix.

As an example, take the following set-up for a medium sized group doing mono PA. Input signals are run through individual input channels (one through twelve, in this case), then assigned to sub-groups. (We're assuming that keyboards are pre-mixed by the keyboard player, then fed to a Line input. Also you'll note there's no drum overhead mic -- lots of cymbal leakage!)

<u>INSTRUMENT</u>	<u>INPUT CH.</u>	<u>SUB-GROUP</u>	<u>CHANNEL ASSIGN</u>
Bass	1	1	1
Kick	2	1	1
Snare/hat	3	1	1
Rack toms	4	1	1
Floor toms	5	1	1
Elec. guit.	6	2	2
Rhy. guit.	7	2	2
Keyboards	8	3	3
Lead vocal	9	4	4
Vocal (guit.)	10	4	4
Vocal (key.)	11	4	4
Vocal (bass.)	12	4	4

* 0 dBu= (.775V rms into any load.)

These channel assignments give sub-group control over the four major components in the mix, making your job a lot easier once the mix within each sub-group is established. The sub-groups are mixed together, through the stereo master control, to form the final composite mix at the mono output. The sub-groups can be panned for your convenience in monitoring and will not affect the mono output.

Using the patching connectors provided, each sub-group may now be processed (compressed, limited, flanged, phased, gates, expanded...) as a group, so you don't have to have one of every kind of signal processor for each input channel. Besides making the mixing job easier and saving you all that money you could have spent on processing gear, four bus sub-grouping allows you to use your four track machine to record the performance. Of course, you can always record off the stereo outputs, but the level of flexibility and control you retain with multi-tracking is obvious.

USING THE PATCHING CONNECTORS AND DIRECT OUTPUTS

The C-12/Series Two products are equipped with a number of access jacks that greatly enhance their flexibility in both recording and sound reinforcement situations. Each input channel and sub-group has a pair of Send/Return jacks, and each input has an additional Direct Output jack.

To the left of the VU meters are three rows of jacks, one set of three per input. The top two rows are the channel patching jacks, Send/Return. These connectors allow the insertion of an outboard signal processing device (compressor, equalizer, etc.) into the normal signal flow of any input. Note on the block diagram that the Send/Return jacks are located before the EQ and fader. The third row or jacks are the Direct Outputs. Signals are fed to the Direct Outputs after they've gone through the channel equalizer and fader.

All signals that appear at the Send and Direct Output jacks will be line level because they've already been processed through the channel's preamp at that point. The Send/Return jacks are "normalled," that is, the normal signal flow through the input channel will be interrupted only when a plug is inserted into the return jack. A plug inserted into the Send jack will not disturb the regular signal flow in any way. This arrangement has several benefits.

Outboard processing gear can be connected to the Send jack without affecting the channel's operation. The mixer's gain Trim and fader settings can be optimized at the same time the controls on the external processor are set. For instance, if a compressor were completely patched into channel before the gain Trim and faders were adjusted, on both the mixer and the compressor, it's likely that some sort of level mismatch would occur. The result could be either clipping distortion, or excessive noise. If the channel gain is too high the compressor's input might be overloaded, and if the compressor's output level is too high the channel's EQ circuitry might take it in the shorts. Likewise, if levels are too low, especially at the compressor's input, noise could cause more trouble than the compressor does good.

In any case it's always best to set up the input channel for normal operation, as if no outboard gear were to be used. Patch the Send to the processor's input, and adjust pertinent controls as much as possible. Then, patch the processor's output to the Return jack (breaking the normal, so the signals are now routed through the processor), and everything should be close to optimal operation.

The patching jacks are in an unusual position in the circuit -- before the channel EQ and fader. This is an important operational feature.

With the compressor as an example again, note that its input and output levels and its threshold and ratio settings need to be set only once with this kind of patching arrangement. Any subsequent changes in fader and EQ settings will not alter the usually critical adjustment of the compressor's controls. Another operational advantage is that the Return jack can be used as an additional line input if necessary, without relinquishing use of the EQ and level controls. In a pinch this comes in real handy. Since levels at the Send jack are affected only by the Trim control, it is ideal for use as an individual channel feed for simultaneous multi-track recording and PA. Once the Trim is set up, levels for the PA can be adjusted the the faders, leaving the tape feed constant for mixing later.

For studio multi-track recording it is more advantageous to feed the tape machine post fader and EQ, for those situations that require a little more "squeezing and stretching" to get the desired signals on tape. The Direct Outputs are subject to the setting of all Input signal controls.

It's important to note that any and all of the patching and Direct Out jacks may be used to provide, or accept, signals from other sections of the mixer. Just a little clever re-routing can provide additional sub-groups, stereo sub-groups, instantly switchable EQ, more returns and sends, etc. There's essentially no way to cause damage to any of the C-12/C8E's circuitry by inter-patching, so don't be afraid to try it. Just don't plug the output of a power amplifier into any of the mixer's jacks please.

INPUTS, OUTPUTS, AND SIGNAL LEVELS

The Input is the beginning of the signal path (sometimes called the goesinta). The Output is the end of the signal path (sometimes called the comesouta). Signals always go into inputs and come out of outputs, so outputs are always connected to inputs and vice versa. Just like the birds and the bees, only different. Intermediate points are usually designated Send and Return, with the Send jack serving as the output, and the Return jack as the input.

Signals exist at many levels, or strengths. In audio, weak signals are generally referred to as mic (for microphone) level. Not so weak signals are considered line level, and strong signals are called speaker level. To give you an idea of how the various levels relate to each other in terms of actual electrical power (volts x amps); mic levels usually range somewhere between five nanowatts (.000000005 watts) and fifty microwatts (.00005 watts). Signals running between fifty microwatts and one watt are considered line level, and anything over one watt is speaker level.

Signal levels in a sound system are most easily expressed in dB. Knowing the approximate level of an input signal allows you to instantly set the gain trim control to a point which will be a good first try. Later on you can optimize the control setting to exactly the right point. The graphics on the C-12 gain trim control reflect the actual signal level required for 0 dBu at the channel patch point. Here is a list of some approximate signal levels.

<u>Device/source</u>	<u>Microphone type</u>	<u>Level (dBm or dBu)</u>
Vocal close mic	dynamic	-40
Vocal close mic	condenser	-30
Voice distant mic	dynamic	-50
Electric Bass	via direct box	-50
Electric Guitar	via direct box	-40 to -50
Acoustic Guitar	FRAP type pickup	-30 to -40
Elec. Guitar or Bass	dynamic mic on amp, close	-30 to -10
Electronic Keyboard	via direct box	-20 to -40
Fender Rhodes (stage)	via direct box	-50 to -60 make sure its <u>wide open!</u>
Fender Rhodes (suitcase)	direct box at "ext amp"	-20 to -40
Drums (kick, snare, toms)	dynamic mics	-30 to 0
Cymbals	condenser	-20 to -30

Both inputs and outputs have specific maximum and minimum operating levels, and outputs usually have a specified minimum impedance into which they will work. The minimum operating level, for outputs as well as inputs, is related to one thing: noise, because all electrical circuits generate some unchanging amount of noise when they operate. When audio circuits are forced to handle signals that are too weak their inherent noise becomes evident, and you hear hiss. The hiss is at a level usually referred to as the noise floor of the circuit. When signals are kept well above the noise floor the hiss is masked by the desired signal, and the circuit is operating well within its normal range of levels. Until the maximum is reached, of course.

A circuit's maximum output level is determined by the voltage on which the circuit is designed to operate, and by the minimum impedance into which the circuit is designed to work. So it'll only put out so many volts into some given load, like 600 Ohms. When the circuit is pushed beyond its limits you hear that harsh buzzsaw kind of distortion. Likewise, inputs have inherent level limitations, also determined in part by the maximum number of volts available within the circuitry. However, inputs don't suffer from any impedance problems other than those incurred by whatever is plugged in, i.e. some kind of output. Of course, they may be 50% responsible for a mismatch if the preceding output has an impedance greater than the input's impedance.

As a general rule, impedance will match if the input impedance is greater than the output impedance of the preceding device. How much greater is a matter of some debate. When a device is asked to work into a load greater (in other words, an impedance lower) than it should, distortion increases dramatically, and headroom is reduced. Most manufacturers specify minimum operating impedances on the order of ten times the actual output impedance of the circuit. All outputs on the C-12/ Series Two products will deliver +18dBm(6.2 Vrms) into 600 ohms before clipping. (Input channel and submaster patch points (Sends) included.)

STEREO AND MONO

The minimum requirements for a monaural sound reproduction or reinforcement system are:

1. one microphone
2. one amplifier
3. one loudspeaker
4. listener with one working ear

In some larger systems there may be many microphones, amplifiers and speakers. The important thing is that in a mono system all the speakers are reproducing exactly the same program material.

The minimum requirements for a stereo sound system are:

1. two microphones, in the same acoustic space
2. two amplifiers
3. two loudspeakers, in a common acoustic space
4. listener with two working ears.

What's important here is that there are two completely separate amplification channels, all the way from the source to the listener. If anywhere in the chain the two signals get mixed together the result is mono.

Most stereo systems, recording or reinforcement, rely on multiple monophonic sources that are panned into some stereo perspective, with panpots. As an example, a guitar is recorded in an isolation booth using one microphone -- it's a mono source. We can pan that source to the left, for instance, so the guitar seems to be localized in a particular spot. You can tell which direction the sound is coming from, but you can't tell anything about the room in which it was recorded because there isn't any ambience. The point is, even though the signal has been positioned with the panpot, it's still a mono source. 16 mono tracks panned in 16 different positions in a stereo panorama is still mono, albeit 16 track mono. Stereo would be created if those same 16 tracks were recorded as 8 stereo pairs, in other words eight sources each picked up by two mics, one feeding the left channel and the other the right.

PHANTOM POWER

Your C-12 is equipped with a +48 VDC Phantom Power supply which is switchable on and off. The switch is located adjacent to the AC Power ON/OFF switch on the front of the mixer. An LED on the front panel indicates the presence of Phantom Power. The DC voltage is applied to all Inputs simultaneously. A general discussion of Phantom Power follows:

All condenser microphones have one thing in common: They all require some kind of electrical power. This power is needed to operate the mic's preamp circuits, and in some cases to charge the capacitive plates that constitute the actual transducer elements. In the newer electret condenser mics the power is used only for the internal preamp because the plates are permanently charged when the mic is built.

Early condenser mics contained tube type preamps. The tubes required an external AC power supply, which was usually connected to the mic through a multi-conductor cable that also housed the audio lines. Transistors have now virtually eliminated the use of tubes in condenser mics because they offer lower power consumption, greatly reduced size, and improved noise performance.

The newer, solid state mics get their power from either internal batteries, or an external supply that is fed to the mic via the audio cable. Most of the battery powered mics may also be externally powered - check the manufacturer's literature for specifics. External power may be applied two ways:

1. Phantom or Simplex powering DIN standard 45 596
2. "T" system powering (also called modulation lead powering, or AB powering), or AB powering), DIN standard 45 595

The difference between the two systems is the way the power is applied to the mic, through the audio cable.

Phantom powering imposes a positive voltage on both audio conductors, using the shield for the power ground. The "T" system imposes a positive voltage on one audio lead, using the other as the power ground. In the "T" system the shield functions, as it usually does in a balanced system, only as a shield. THE TWO SYSTEMS ARE NOT COMPATIBLE WITHOUT SPECIAL ADAPTERS.

The term "PHANTOM POWER" specifically means one thing: +DC applied to the microphone on both pins 2 and 3 through a current limited network.

The following microphones are "T" system powered and are not phantom power compatible under any circumstances:

Neuman: FET 70 series, KTM
Sennheiser: MKH 110(-)
MKH with T suffix
MKH 435 U
MKH 415, 815 (compatible with suitable adapter)

The following microphones use a remote powering system unique to them and are compatible only with their unique power supply. They will work in a phantom powered system regardless of whether phantom power is on or off:

ALTEC: M20, M21, M50, M51
AKG: C 60, C 12, C 24
Neuman KM 56, KM 64, U 47, U 67, M 49, M 269
Sony: C37, C37A

The following microphones are phantom power compatible but do not require power. Some of the microphones listed are condenser types that are battery powered only

All EV pro series (RE-15, etc.)
All EV PL series (except PL 77, which is battery or phantom power)
All EV 600 series low impedance
Shure SM series
Shure 500 series wired low impedance
Shure PE series (low impedance only)
Beyer dynamic and ribbon mics
RCA broadcast mics
AKG D series
ANY MICROPHONE WITH A BALANCED LOW IMPEDANCE OUTPUT

The following microphones are phantom power compatible, and do require power for operation:

AKG: C series, CE series
Beyer: Electret condenser series
EV: PL 77, PL 77A, 1777, 1778, CS15 series, PL 76 (when used with 506 adapter)
Sony: C74, C76, C37P, C38B, ECM Series (Balanced Out Only)
Shure: SM81
Neuman: KM83, KM84, KM85, KM86, U 87, U 89, U 47FET

If your microphone isn't listed here, consult the data sheet, the manufacturer, or TAPCO.

CAUTION: A "T" powered mic may be damaged by +48 V Phantom Powering. Always check manufacturer's specifications before applying power to any microphone.

Some dynamic and ribbon mics may exhibit random noise (crackling, sputtering, or even humming) when used in a Phantom powered system. The problem is that the transformer inside the microphone has developed leakage, from the winding to the microphone case (pin 1). It's the leakage that causes the noise, not the power. There are three solutions:

1. Turn off the Phantom power.
2. Insert a 1:1 isolation transformer in series with the bad mic.
3. Get the mic repaired.

STANDARD PATCHES AND BOARD SETUP

The first and probably simplest of the standard patches is the mono PA patch. Later on we will cover stereo PA, simultaneous recording and just plain recording. The intent of this section is to give you a starting point for your own patches. Therefore, do not accept the following words to be the only possible way to get there from here. Rather, by studying these patches and understanding how and why they work, you can gain an understanding of the C-12 mixing system that will enable you to create your own.

MONO PA

Here is the situation: Simple 5 piece band. They need 1 monitor mix for floor monitors. The house PA is mono. The lead singer is really into tape echo and has a Roland Space Echo to prove it.

Plug all microphones into the C-12's microphone inputs and then make the following additional connections:

1. Mono output to power amp input or equalizer input.
2. Monitor send to monitor amp input or equalizer input.
3. Since the Space Echo is a guitar level type device, we use the effects send L0 Jack along with the effects return A or B L0 jack. The send connection goes to the number 3 input jack on the Space Echo or to the 'from PA' jack. Set the output level switch on the Space Echo to H and the blend or mix knob to maximum effect.

Now assign the various inputs to the four submasters as appropriate. As an example, you might assign drums and bass to sub 1, guitars to 2, keyboards to 3 and back-ground vocals to sub 4. Since the front man is all alone and does all vocal leads, we will create the fifth subgroup by using the direct assign switch.

Now set the trim controls. A good place to start is around -40 for vocals and -30 for instruments. With the input faders down, bring the submaster faders to -12 (heavy mark on front panel graphics) and the stereo master to about halfway open.

As you bring the input channels up to the -12 mark, reset the gain trim controls as necessary. If a peak indicator lights, back the trim control off slightly. Shoot for 0 level peaks on the submaster meters. If a submaster is too 'hot', reduce the trim control settings further. What you want when you are done is to have all channel gain controls (slide faders) at -12 as well as the submasters. This will assure maximum headroom within the board. If the level gets too loud, reduce the setting of the stereo master. Likewise, if there is not enough level, raise the stereo master.

Now set up the monitor mix on the top row of the send controls. You can solo the monitors in the headphones or into the main PA. (Main PA by depressing SOLO TO L/R STEREO) The individual monitor pots should be run at least halfway open. Set the monitor master for the desired overall monitor level.

Setup your effects mix on the effects pots. Assign the meters to read the solo bus and solo the effects master. This will help you to set levels. Be sure that the solo level control is set to the 'CAL' mark to insure accurate meter readings. Set the effects send master for approximately 0 level peaks on the meter. Set the Space Echo input level control for normal looking levels on its VU meter. If you used the FROM PA jack for hookup, you will have to set levels using the C-12 effects send master. Set the echo/reverb/repeats/etc. controls on the Space Echo to suit your own preference. Then adjust the amount of echo by using the appropriate return control. Don't use the blend control on the Space Echo.

All preliminary settings are now made. During the course of the mix, make mixing changes on the individual channel controls, subgroup level changes on the submaster level controls and overall volume changes on the stereo master. Be certain the SOLO TO L/R STEREO switch is up at this time before using the solo system. (Unless you deliberately want the audience to hear just the soloed input)

EFFECTS

When the effects bus is used for external effects devices, like the Tapco 4400 Reverberation System, the signal path begins at the individual channel Effects send control, goes through the Effects Master, to the Effects Outputs, through the effects device, then back into the mixer through the Effects Return(s). In the case of the 4400, the Hi level Effects output and Hi level Effects Returns would be used, because the 4400 is a line level device. If guitar level effects were used, like the Roland Space Echo, the Lo level Effects output and Lo level Effects Return would be used.

Both the 4400 and the Space Echo are series type effects units -- they can be used without the need for any effects mixing capability, because both units already have controls that allow the operator to set the ratio between the effects and straight signal. But when an effects device is used in the console's effects send and return loop, the controls on the console are used to set this ratio, because the effects send/return system is designed for parallel operation of effects generators. So, the mix or blend controls on the effects unit must be set for maximum effects. Allowing no straight signal to be returned to the mixer. If straight signal is present in the effects signal the loudness of the entire PA will be increased when the effect is used. And, if the effects unit just happens to cause a phase reversal, there will be a point at which the signals from the effects unit will tend to cancel the main signal. (Half the effects devices available in the world invert phase!) This will not happen if no straight signal is present.

The Effects Master control should be used to set an appropriate level for the effects unit, as indicated by the unit's meter or LED's. If there are no level indicators on the effects unit the output level should be observed on meter #1 via the solo system. A normal level indicated here should provide approximately the right level to the input of the effects unit. The Effects Return level should be set so the headroom of the effects device is not stressed, but low enough so noise is not a problem. The exact level will be different for every device and every situation. You can usually determine what the best send and return levels are by listening to the effects return signals by themselves, on headphones with the gain turned up. As with the input channels, the Effects Return Pan pot setting is not important because this is a mono setup.

MORE EFFECTS

There are several possibilities. One is to parallel (we cord) them onto the effects bus output. Use the other effects return for the second effect unit. If one of the effects devices is line level and one is guitar level, use both the high and low output jacks. Then use separate returns.

Of course, you can always use the AUX bus.

Other possibilities for effects returns would be to use an input channel line input. If you do this, you have the option of returning the effect to the monitor mix.

If you don't have an input to spare and are out of effects returns where can you patch additional line level effects into? *

MORE MONITOR MIXES

The easiest way to get additional monitor mixes is to use the AUX bus. Simply patch the second monitor amplifier input to the AUX output jack. Remember that the AUX bus is the pre or post bus. If you turn the knob left of center it is pre pre fader, pre EQ. If you turn it to the right, it is post fader, post EQ. In some situations, it might be an asset to have one or more inputs that feed a monitor system to be post fader instead of the usual pre fader. A good example is a mike that is used infrequently, but needs monitor access when it is. By making it post fader, you can keep it out of the monitor mix when it is not being used. This will help keep the additional microphone from picking up leakage and possibly reducing the feedback threshold.

AUX BUS

The Aux bus, with its selectable pre/post function, may be used for effects, monitors, or to provide a separate mix for any other purpose. Signal flow is the same as the other two buses, and levels are observed through the solo bus, on meter #1

SIMULTANEOUS RECORDING

There are several ways to do mono, stereo, multi-track recording at the same time as mono PA.

A 4 track tape machine may be connected directly to the sub-group outputs. This will put four discrete tracks on the tape. Later the four tracks may be mixed down to stereo or mono, through the mixer's line inputs.

With a stereo recorder the setup is even simpler: just connect the machine's line inputs to the Stereo Left and Right outputs. The two tracks will be composed of the four sub-groups, positioned onto the stereo buses via their panpots. If the sub-group orientation is planned in advance for two track recording, the sub-groups could be arranged so vocals and leads were on one side, and the rhythm section was on the other. This will allow some form of mixing to be accomplished later.

To check the PA mix, a mono recording may be made by Y-cording the Mono output to the line input of a tape machine.

*Answer: By using the stacking input jacks into the submasters or stereo master.

SOME OTHER WAYS TO DO IT

Since the object is a mono PA mix, and since that mix is merely the sum of the left and right stereo signals, you can do a good stereo mix for recording and still have the same mono PA. The settings of the Pan pots will not affect the PA mix at all. There are many ways to do stereo as well as 4 track recording, while still doing the usual mono PA.

The easiest way to get a stereo recording is to run the stereo outputs to the tape machine. Set the Pan pots for a pleasing stereophonic balance. Since the Pan pots are not hard left or hard right, the signals from some inputs will appear on more than one sub-group. Some of the flexibility available from the sub-group system will be lost. To retain some sub mixing capability a stereo pair may be created on two of the subs; composed of the rhythm section for instance, while the other two subs might be used for leads and vocals. To get the vocals and leads to appear centered in the stereo mix (on both sides, that is) pan them to center.

As you can see, panning the signals this way puts subs 1 and 2 on both sides of the stereo mix, so they will appear centered. At the same time a good sense of stereo perspective can be created with the rhythm tracks. This track assignment technique could be reversed so the vocals would be in stereo if the music were more vocally oriented.

Bear in mind that the acoustical contribution from the stage will not be as evident on the tape as it is in the room. Having some kind of separation on tape between prominent stage instrumentation and those sources heard more directly on the PA will help you get a better recording later.

In a situation that requires only vocals on the PA, the stereo recording may be made still another way. All the vocals may be assigned to one sub-group, which will feed the amplifier chain directly. A stereo pair may then be created on two other subs, with the remaining sub-group used for leads (or what have you). Centering may be accomplished as above. It should be obvious by now that there are many more ways to record stereo while doing more mono PA -- use the block diagram to put together the patches needed for the situation at hand.

The same holds true for simultaneous 4 track recording, so only one of the many techniques will be described. The tape machine gets its signals directly from the sub-group Sends, but, channel assignments are made so those signals necessary on the PA are placed in stereo perspective on two of the subs. The PA feed is taken from the mono output, and the other two subs (with signals not needed on the PA) are kept from the mono mix by inserting dummy plugs in their respective Return jacks. In this way they may be mixed for the recording rather than the PA, and some of the sub-group flexibility will be retained.

If it is necessary to retain the use of the entire main output section of the console for recording, a mono PA mix may be created with the solo system. To accomplish this the PA feed would be taken from the Headphone output, with all appropriate input channel solo buttons depressed. In this case the solo level control serves as the mix amp gain control, and should be operated as low as possible to preserve headroom. The Headphone Level control may then be used to set the output level

to the PA system. The obvious disadvantage here is the loss of the solo system. Obvious advantage; free use of Channel Assigns, Pan pots, Sub-group levels, Effects Returns, etc., for recording. To get effects into the PA signals, use an input channel.

These are only a few of the many ways to do mono PA along with some sort of recording with C-12. The consoles are provided with many, many patching and access connectors so you can arrange signal routing to suit the needs of the moment.

AN UNUSUAL RECORDING PATCH

Assign input channels directly to the stereo outputs as well as the 4 submasters. The C12-II can allow you to make a 4 track recording at the same time as live PA. The recording track assignments are independent of the PA feed, as are the submasters that feed the tape machine. Here's how:

Connect the tape machine's line inputs to submasters 1 through 4. Insert phone plugs into the four submaster returns to break the normals. You can also use 2 patchcords to accomplish the same. Since you are patching input to input, nothing will happen except breaking the normal (which is what you want). Connect the house PA to the stereo or mono outputs of the C12-II. Make your track assignments on the 4 channel assign switches on each channel. Direct assign each input channel that you want in the house PA. The stereo master will control the overall volume of the house PA. The submasters will control the levels going to tape. Because of the plugs inserted into the submaster return jacks, the tape assignments and PA assignments will remain separate. The trackmix and PA mix are still related via the channel pan and level controls. This can cause the same balance problems as when directly recording the PA mix. This is covered in another section.

If you have an eight track or larger machine, you can use a combination of this technique plus any of the sends, or direct outputs. It is also possible to only patch out one or two of the four subgroups. Use your imagination.

STEREO PA

All connections for stereo are as above except the house amplifiers and/or equalizers will connect to the L and R stereo outputs.

All settings will be the same except for the selection of the subgroups. There are basically three ways to use the subgroups in stereo.

1. 3 stereo groups: Use the direct stereo assign for one group and the four submasters for the other two groups. Use even odd pairs of submasters (such as 1 & 2 or 3 & 4). Pan the submasters left and right within each stereo pair. Remember to depress two assignment switches on the input channel when assigning to the submasters. You will now have 3 stereo groups.
2. One stereo group and 4 mono groups: Use the direct assign for the stereo group and create 4 subgroups using the individual channel assign switches and the 4 subgroups. The 4 mono groups may be panned as desired

within the stereo field. A starting suggestion would be to put the rhythm section directly into the stereo outputs using the direct L-R assign switch. Then create 4 subgroups out of the remaining lead instruments and the vocals. This will result in your mix having more stereo dimension and depth because of the large number of panpot assignments possible when using the direct stereo assign. Remember: Panpots do not make stereo.

3. 2 stereo and two mono: Assign as in 2 above except use 2 of the 4 subgroups for a stereo subgroup. Everything else is the same. Remember to pan the two subgroups you are using for stereo hard left and hard right.

In any case, care must be taken when any input channel is panned to the extreme. With most stereo PA's half of the audience will not be able to hear any sound that is placed in the stereo image furthest away from their listening position. The negative effects of stereo PA may be greatly reduced by limiting the range of panning for all inputs, excepting special effects, of course. In some cases the available gain before feedback of the system may be increased with clever panning arrangements, resulting in a cleaner overall sound. Even when more gain is not needed, the reduced mic to mic and speaker to mic leakage will tend to make the total mix sound better.

STEREO EFFECTS

Effects devices designed to provide stereo outputs may be returned to the main mix through the Effects Returns, Sub-group stacking jacks, Stereo stacking jacks, input channel line inputs, or input channel patching Return jacks. When two channels of reverberation are available, as with the Tapco 4400 reverb, a more realistic sounding effect will be created if both reverb channels are driven from the Effects output, and returned to the mix panned hard left and hard right. Use a Y-cord to get the Effects Send signal from the console to both reverb inputs, then route the reverb signals back to the mix as described above. This technique may also be used when making stereo recordings with mono PA.

MONITOR AND AUX BUS

The monitor and Aux buses are used the same way as described in the mono PA section, when they are used for their usual duties. Additionally, either or both of these buses may be used to provide "fill" signals for the stereo PA or recording mix.

There are several reasons that PA mixes often don't sound so good on tape. One, as mentioned in the mono PA section, is that the acoustical contribution to the recorded mix from stage sounds is often insufficient for good balance. Another is that the gross frequency response irregularities produced by some speaker/room combinations require almost radical EQ on some inputs, just to get an acceptable level of intelligibility on the PA. PA mixes are normally not as "tight" as recording mixes, the vocals are usually more out front in PA work than they might be on a recording.

The Monitor, AUX, or Effects bus may be used to enhance the recording mix. As an example let's assume that all of the above problems applies, and that the resulting recorded sound is just not acceptable, even though the PA sounds OK. A "stereo" recording could be put together using the Monitor and Aux buses as substitute left and right buses. With the pre/post function of the Aux bus, those inputs that sounded better with the PA EQ could be fed to the tape machine post, while those that sounded better flat could be derived "pre." With careful mixing a good stereo panorama and well balanced sound can be created this way, completely separate from the PA mix.

A stereo recorder with mic/line input mixing enables you to use the Effects bus to "fill" vacancies that may exist in the recorded PA mix. If, for instance, there are not enough drums in the recorded sound, a drum mix could be put together on the Effects bus, and fed to the mic input on the tape machine. The Lo level Effects output would have to be used to feed the mic input on the tape machine, and the levels would have to be watched carefully to avoid overloading the machine's input. If necessary, the drum mix created in this manner could be fed to both channels of the tape recorder. An appropriate level for the drums in the recording is then set with the tape machine's mic level controls.

OTHER OPTIONS

The options for producing a stereo recording while doing stereo PA are essentially the same as for stereo recording with mono PA. A PA mix may be set up on two of the Sub-groups, while two others are used for recording. Dummy plugs may be used to keep certain subs out of the PA, and so on. Again, don't hesitate to try something that may at first seem strange -- if it gets you where you want to go, do it.

RECORDING PATCHES

Recording with the C-12 is a little more difficult than doing just PA, unless the recording is a live stereo mix. In that case, the same set up as described for stereo PA will do just fine. For purposes of this discussion, let's assume that 4 tracks are available, with a machine like the Teac 34405, Tascam 40-4, or the Otari Mx5050-4. The specifics of interfacing those machines, and any noise reduction equipment that may be used, will be left out of this section on the assumption that you've already read the tape machine owner's manual, or have been shown the procedures somewhere along the way. It's also assumed that the intent is to work within the constraints of the tape machine's performance limits to produce a good quality demo recording, i.e. no ping ponging is used so all tracks are first generation recordings. The recording is to be a five piece band with 3 vocals.

The process, when considered as a basic two-step procedure, is really quite simple. First, the tracks are recorded, singly or in multiples, until all four tape tracks have been filled. Then they are mixed down, through the line inputs of the console, with various effects and panning techniques used to create a well defined stereo mix. Most of the difficulties encountered in this process come up in the first step, the recording (and overdubbing) of the 4 tracks.

To effectively record the tracks, all those involved must be able to hear everything that's going on. The musicians must be able to hear one another, as well as any previously recorded tracks that they're playing along with. The engineer must be able to monitor the recording in a way that will help to reveal any problems that may occur in the original recording process. This allows those problems to be corrected during the original recording, whereas they may not be correctable during mixdown. To keep close track of what's being put on tape, the engineer should monitor the original recording in the same format as the intended final result -- in this case 2 track stereo, with effects as necessary.

MUSICIANS CUE MIX

To begin to approximate the standards of most commercial recordings these days it's necessary to have some kind of acoustic isolation between the various instruments. Unless the desired result is a very live sound, leakage must be minimized. This also means the musicians may not be able to hear each other very well. The solution is a mix generated on the Monitor bus and fed to the musicians through headphones, to give them all the volume they need without disrupting the acoustical isolation.

The console's headphone amplifier will adequately drive several pair of high impedance phones (like Sennheisers or AKGs), but you may not be able to reach the threshold of pain with more than 2 pairs of 8 ohm phones. You can use the Monitor system, soloed, to operate the headphone system this way. Or better yet, use an external amp driven off the monitor output to run the phones so you don't have to give up the use of the solo bus.

CONTROL ROOM MONITORING

For the engineer's control room monitoring, two of the Sub-groups are used. The signals heard in the control room are from the tape machine's outputs, through the line inputs on channels 9 - 12 which are assigned to Sub-groups 3 and 4. The amplifier used to drive the control room speakers may be plugged in to either the stereo outputs (if dummy plugs are inserted in sub 1 and 2 Returns), into sub 3 and 4 Sends, or into the Headphone jack. To retain use of the solo system, either the Stereo outputs or the Headphone output must be used. In this case we've elected to use the Headphone output so that two track mix down machine may be connected "permanently" to the Stereo outputs. If the Headphone output were needed for something else (headphones, maybe?), we could simply take our control room monitor feed from the outputs of the two track machine (more on this in the part about mixing). You could also use the L-R STEREO assign with the 4 subs patched out.

GETTING SIGNALS ON TAPE

The first goal in the actual recording process is to make all the signals fit into the relatively small dynamic range of the tape recorder. Even with good noise reduction equipment, the tape recorder is the limiting factor in the battle against noise and distortion. So, the tracks are recorded without consideration for track to track balance. All tracks are recorded at the same approximate level. The musical balance is restored for the engineer's benefit by the monitoring setup detailed in the preceding paragraph, and is permanently restored on the two track master tape during the mixdown process.

NOTE: The EQ controls on the four inputs used for monitoring should always be run flat during the original track recording so you don't think you're getting something on tape that really isn't there. And, if it's at all possible, the tracks themselves should be recorded sans EQ so you don't end up with a bunch of tracks that somehow don't seem to fit together very well in the mixdown. Fixing it in the mix is usually more trouble than it's worth.

During the actual recording the Effects bus may be used to add effects (like reverb) to the tracks as they are put down, or just to add effects to the signals as they return to the console for monitoring purposes. The same cautions must be applied here as those pointed out in the discussion about adding EQ when doing the tracks, sometimes it simply can't be avoided, but don't add effects to basic tracks unless you have to. In either case, effects may be routed through an input channel, the Effects Returns, or stacking jacks. Use the method that best suits the situation.

THE ACTUAL RECORDING - BASIC TRACKS

The band consists of electric bass, drums, electric guitar, piano and saxophone. The first tracks recorded will be a stereo pair of rhythm tracks played by bass, drums, piano and guitar. Later, 3 part harmony vocals, and both guitar and sax solos will be overdubbed.

Since four channels are going used for control room monitor mixing the eight remaining inputs are used as follows:

1. Bass - center
2. Kick drum - center
3. Snare/hat - center or slightly out, depending on the L and R mics
4. Drums left - full left
5. Drums right - full right
6. Piano high - full left
7. Piano low - full right
8. Guitar - center

The stereo panorama created with this panning arrangement should be strong enough to support any overdubs that may be added, wherever they may be positioned. Let it be understood that this is only one of the countless ways the various sources could be panned, depending entirely on taste.

The eight inputs are assigned to Sub-groups 1 and 2, which are patched to line inputs 1 and 2 on the tape machine. Control room monitoring is being done through channels 9 and 10, which are getting signal from tracks 1 and 2 on the tape machine, and are assigned to subs 3 and 4. (Remember that subs 1 and 2 are not directly heard in the control room monitors because they've been "dummied out." They are being fed to the tape inputs, then returned through Channels 9 and 10.)

OVERDUBBING VOCALS AND SOLOS

To make things easy, vocals will be put on one of the remaining tracks, and solos on the other. First the vocals, because the leads will be doing fills around the vocal phrasing.

The previously recorded tracks are fed to the musicians phones, along with the vocal parts, via the Monitor bus. To establish the proper balance in the phones mix, solo the Monitor master in the control room speakers, and work with the vocalists to get the balance they need for timing, intonation, etc. When this is done the vocals can be put on the tape. It's usually a good idea to put a little reverb on the musicians phones at this point, through an input channel that's fed only to the monitor system not to the tapes. If necessary, the tape machine's "punch in" facility may be used to piece together the vocal track, replacing the mistakes, without losing the good parts.

The vocal mic(s) are assigned to Sub-group 1, which is then patched to track 3 on the tape machine. Use one mic if possible, but use as many as necessary. More mics means more potential problems with leakage, so take care that the track is clean and free from phasing inconsistencies when it's recorded.

When an acceptable vocal take is completed, the same procedure is followed for the guitar and sax solos, which will be played together and put on track 4. Both inputs are assigned to sub 1 or 2 and then patched to tape track 4. Once an acceptable take is obtained, the tape is ready for mixdown.

MIXDOWN

To combine the four tracks onto one two track stereo tape, the input channels that were used for monitoring are now used for mixing. Channels 9 and 10, handling the original stereo rhythm tracks, should be panned hard left and hard right. Any other panpot setting will tend to negate the stereo effect that was originally put on those tracks. The other two tracks, vocals and solos, may be placed wherever they feel right in the stereo perspective. Unless these tracks are processed with some delay, or a stereo synthesizer, they will probably sound best placed front and center.

During the mixdown the tracks should be equalized if they need it and any effects that are required should be added. The object is to attempt to create the same kinds of dimension, perspective and mood that might be conveyed by a fine painting. The various sounds should have a variety of "colors," be they subtle or obvious. The scope should tend to make the listener feel they're involved. And the perspective should have depth and distinction. But most of all, the many aspects that go together to create the total sound should support the idea, or mood, that is the reason for the existence of that particular piece of music. No matter what you do in the recording, processing or mixdown, if it supports the musical concept it's appropriate.

Since the mixdown is the culmination of a great deal of planning, rehearsal and performance, it only makes sense to approach it with great care and patience. Do it 'till it's right, try lots of different techniques, and make several masters with different mixes. Listen to the results on small speakers, big speakers, headphones, everything you can find. And, remember, a good mix sounds good on virtually any system.

BEYOND 4 TRACK

The C-12 and an 8 track recorder may be used for even greater control. And, with the addition of a C-8E, a 16 track recorder may be used. In either case, the combination of 4 Sub-groups and the availability of direct outputs from the individual input channels will usually provide the track assignment and grouping versatility necessary for recording almost anything.

A combination of the channel Direct outs and two of the subs may be used to get signals into the 8 track. Inputs that are a single source, like an electric guitar or bass for instance, require only one mic or direct box, and only one track on the recorder. Other instruments, like drums, acoustic pianos, acoustic guitars, and groups of horns, can be recorded with one or two mics on one track, or two or more mics on two tracks. The choice will be made by the particular style of music being recorded. With choral music the voices would be the dominant instrument, and would receive preferential treatment. With some electric music, perhaps a stereo Rhodes, the drums and harmony lead electric guitars would be recorded in stereo, while most other sources were mono. Again, whatever is appropriate and suits the taste of those involved is right.

As an example, here is a track assignment that might be made with an 8 track, recording a medium size rock band.

<u>Console Input #</u>	<u>Instrument</u>	<u>Sub-group Assign</u>	<u>Recorded on Track:</u>	<u>Output From:</u>
1	Bass	4	1	Ch. Direct out
2	Kick drum	1-2	2-3	Sub Direct out
3	Snare/hat	1-2	2-3	" " "
4	Small toms	1-2	2-3	" " "
5	Large toms	1-2	2-3	" " "
6	Drum o'head	1-2	2-3	" " "
7	Lead vocal	3	4	" " "
8	B/g vocal	3	4	" " "
9	B/g vocal	3	4	" " "
10	Elec guitar	4	5	Ch. Direct out
11	Acous. guitar	4	6	" " "
12	Organ	4	7	" " "

This track assignment leaves one track open, which might be used for another lead vocal, percussion, a second keyboard, etc. Notice that the tape tracks inputs are fed from a combination of channel direct outputs and sub-group outputs, and that sub 4 is used only for monitoring purposes. There is a certain amount of risk involved in building a mix like this, especially if there is significant leakage, and if tracks with leakage are processed through outboard equipment with questionable phase coherency. However, every input and output on the C-12/ Series Two products is in phase, so any problems will be generated outside the console.

Arrangements for 16 track recording would take a similar form, but would require a C12 and C8E for mixdown. Since the requirement for multiple mix groups is inversely proportional to the number of available tape tracks, four Sub-groups will be sufficient for almost any multi-tracking situation from 8 on up.

C-8E/SERIES TWO EXPANDER

INPUT CHANNELS

The C-8E Expander has eight input channels, identical to any of the 12 input channels on the C-12. Consult pages 2-5 of this manual for information concerning features and other details of input channel operation and specifications.

FRONT PANEL PATCH BAY

Like the C-12, the C-8E has a front panel-mounted patch bay. Each input channel has a set of 3 1/4" phone jacks in a vertical set. The uppermost jack is a pre EQ/fader direct output, the center jack a return point that allows signal to be returned to the input channel from a processed signal source, or effect. These two jacks are a normalled pair that allow use of the pre EQ/fader channel output without interrupting the use of the channel. The return jack will break the normal if a 1/4" phone plug is inserted in the jack. Signal to the rest of the input channel would be supplied by the return. The third jack in the set is another direct output, post EQ/fader. These jacks allow use of special equalization, processing, or effects on an individual channel level. They can supply signal to other mixers, multi-track tape recorders, etc.

POWER ON/OFF AND LED INDICATOR

Along the front edge of the C-8E is the Power On/Off switch. On the top panel is a green LED to the right of the input channel section. The LED will light when power is switch "on." Powering the C-8E requires some basic operating considerations.

First of all, the C-8E, like any other component in a sound reinforcement or recording system should be switched off and/or unplugged when making any connections to or from the unit. Because the C-8E has an AC receptacle on the rear panel that's "unswitched" or not affected by the main power on/off switch, keep it unplugged when starting to set up the system.

Doing that, and following this next procedure will prevent any possible damage from occurring to loudspeakers due to turn on/off transients. Always switch mixers and other equipment pre-power amp on FIRST. Allow a few seconds for all the equipments' power supplies to stabilize. Then switch the power amps on. When

shutting the system down, reverse the procedure: turn power amps off first, then mixers and other auxillary gear. It is also a good practice to keep all gain controls down until the system is fully powered up, and when shutting the system down. The system you save will probably be your own.

PHANTOM POWER ON/OFF AND LED INDICATOR

Next to the main power switch on the front edge of the C-8E is the Phantom power on/off switch. On the right hand side of the top panel, below the main power indicator LED is the green Phantom power "on" LED. This LED will light when the C-8E's +48V Phantom power supply is switched on. For more information on Phantom power see pages 11-13 of this manual.

C-12/C-8E INTERCONNECT AND C-8E REAR PANEL CONNECTIONS

Before attempting to interconnect a C-8E and a C-12, a word about cords needed to do the job is in order. Eleven cables, standard $\frac{1}{4}$ " phone plug to $\frac{1}{4}$ " phone plug terminated, 36" or longer will be needed to properly connect the two units together. The cables must be shielded. If you plan to use more C-8Es in the system, multiply the 11 cords times the number of expanders to do the job. One C-12 and one C-8E need 11 cables, one C-12 and two C-8E Expanders need 22, and so on.

To successfully interconnect the C-12/C-8E, make sure, completely sure, the cables are in good order, properly soldered and well-made to withstand flexing and bending. This is the time a good cable tester should be used (each time) in setting up the C-12 and C-8E. The system will work only as well as the cords and cables between them. TAPCO does not recommend the use of coiled guitar cables to interconnect the C-12 and C-8E. Select a heavy, studio grade cable for the job. Trust us, it will be well worth the minimal dollar spent for trouble-free operation of the system.

Of course, in an emergency, a guitar cord or inexpensive cable can get the C-12/C-8E through the night, but select quality first, for best results.

C-8E REAR PANEL CONNECTORS/C-12 INTERFACE

The C-8E outputs and Stacking inputs are located on the rear panel. Before connecting anything to the C-8E or C-12, make sure power is switched "off" and/or unplugged. The group of 11, $\frac{1}{4}$ " phone jacks marked "Outputs to Stacking Inputs" are the C-8E's outputs to the C-12. The group of 11, $\frac{1}{4}$ " phone jacks to the right of the Output jacks are the C-8E's Stacking inputs. These are functionally the same as the Stacking inputs on the C-12. They allow the use of more C-8Es with the system, perhaps even another mixer.

The C-8E outputs, via the interconnect cable go to the Stacking input bus on the C-12. The C-8E output signals are inserted into the individual functions on the C-12. For example, the output from the C-8E monitor jack becomes number "13" input to the monitor summing bus on the C-12. Technical? Okay, this simply means that TAPCO's C-8E and C-12 employ a system that allows full functional control of both units to be handled by the C-12 Master unit. See figure one for the direct connections between both units. The column on the left is the stacking input bus on the C-12, the right hand for the C-8E.

FIGURE 1

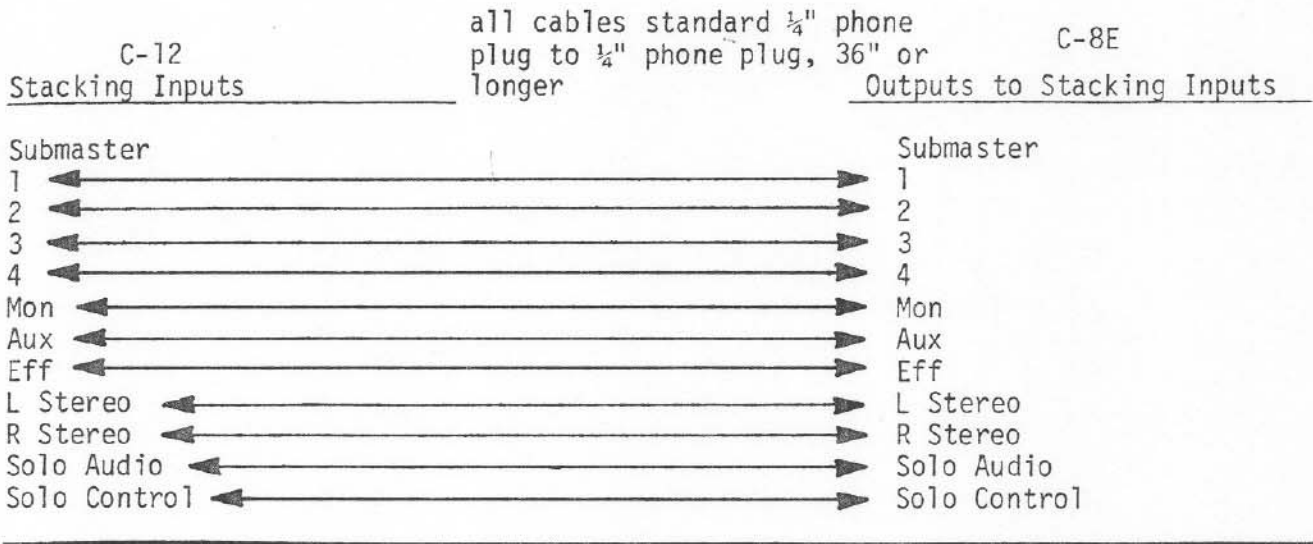

The C-8E also has a set of jacks for stacking another C-8E to the system. To do this, simply do a direct interconnect between the second C-8E's output group to the Stacking Inputs of the first C-8E. Remember, you'll need eleven more cables to do this.

AC OUTLET (DOMESTIC MODEL ONLY)

The AC receptacle on the rear panel of the C-8E allows another C-8E, or master C-12 to be powered from this point. The outlet is "unswitched" so if the C-8E is plugged in, the outlet will still have power whether the C-8E is switched on, or not. This AC outlet is 120V, 60Hz, 800W maximum.

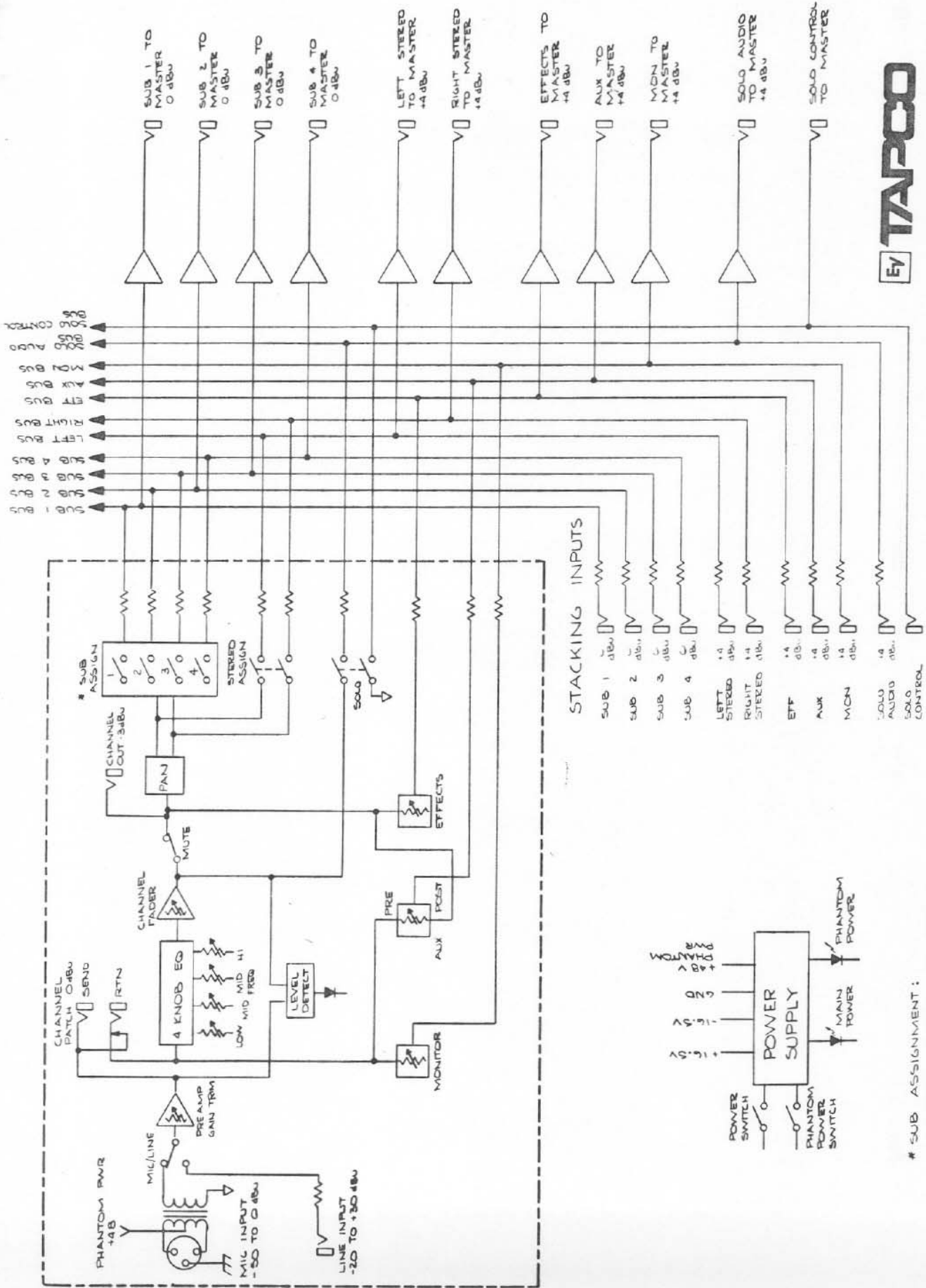

EV **TAPCO**

C-8E/SERIES TWO

SUB ASSIGNMENT:
THE PAN CONTROL IS ACTIVATED WHEN ANY ODD/EVEN BUS COMBINATION IS ASSIGNED. FOR EXAMPLE:

ASSIGNMENT	PAN CONTROL
SUB 1	NONE
SUB 1&2	1 → 2
SUB 1&3	NONE
SUB 1,2,4,5	1,3 → 2

C-12/SERIES TWO MIXING SYSTEM

Specifications (Typical)

Frequency Response:

Mic Input: ± 1.0 dB,
20Hz to 20kHz
(150 ohm source, 44dB gain,
normal gain structure,
+4dBm at Stereo Outputs)
Line Input: ± 0.5 dB,
20Hz to 20kHz
(14dB gain, normalized gain
structure, +4dBm at
Stereo Outputs)

T.H.D.:

Mic Input: .4% at 20 Hz
.1% at 50 Hz
.03% at 100Hz
.01% at 1kHz
.02% at 20kHz
(150 ohm source, 44dB gain,
normalized gain structure,
+4dBm at Stereo Outputs)
Line Input: .02% at 20 Hz
.01% at 1kHz
.02% at 20kHz

CCIF IM Distortion:

.02% (19kHz & 20kHz mixed 1:1,
normalized gain structure,
+4dBm at Stereo Outputs
Mic or Line Inputs)

Equivalent Input Noise:

-129dBV
(20-20kHz NBW, 40dB gain,
150 ohm source, measured
at Channel Patch Send)

Output Noise:

-80dBV, 1 channel assigned
-72dBV, 12 channels assigned
-70dBV, 20 channels assigned
-68dBV, 28 channels assigned
-67dBV, 36 channels assigned
-66dBV, 44 channels assigned
(20-20kHz NBW, 44dB gain,
normalized gain structure,
150 ohm source measured at
Stereo Outputs)

Maximum Mic Input Level:

0dBu (1kHz) (.775Vrms)

Maximum Line Input Level:

+30dBu (25Vrms)

Maximum Preamp Gain:

50dB

Maximum Total Gain:

84dB, (mic input)
54dB, (line input)

Phantom Power:

+48VDC, regulated
60mA maximum current

Input Channel Equalizer:

± 18 dB at 50Hz, shelving
 ± 12 dB sweep range 300Hz
to 6 kHz, peaking
 ± 18 dB at 15kHz, shelving

Dimensions: C-12 C-8E

W - 28.5"	W - 17"
H - 9.5"	H - 9.5"
D - 29"	D - 29"

Weight: 49 lbs. 33 lbs.

Power Requirements: 120V, 25W*
60Hz,
60W*

*100, 220, 240V 50Hz models available.

Specifications subject to change without notice

FUSE

120V and 100V models: 3/4 amp fast blow. Type AGC 3/4 or equivalent.

220V and 240V models: 5x20mm miniature, .4 amp fast blow. Type GMA 4/10 or equivalent.

Make sure that mixer system power is switched off before changing fuses. If the fuse blows again when power is turned back on, turn the mixer off and visually inspect for any problems that could cause it. If no problems are evident, refer the unit to an Authorized TAPCO Service Center.

C-12 and C-8E Series Two OPTIONS

WOOD END PANELS AND ARMREST

The C-12 and C-8E Series Two mixers come standard from the factory with solid oak end panels and padded armrests. They are provided in easy to assemble kit form.

Units may be ordered without end panels and armrest for installation in road cases, or for other special applications.

An armrest/divider kit is also available for joining expanders to master units and expanders to expanders.

WARNING: THIS ATTACHMENT METHOD IS INTENDED FOR TABLE TOP USE ONLY! IT IS NOT A STRUCTURAL CONNECTION. UNITS CONNECTED IN THIS MANNER SHOULD ALWAYS BE SUPPORTED AT THE CENTER INSERT AS WELL AS THE SIDES AND SHOULD NEVER BE LIFTED OR CARRIED WHILE ATTACHED. FAILURE TO HEED THIS WARNING WILL VOID YOUR WARRANTY!!!

BALANCED OUTPUT OPTION

The C-12 Series Two may be ordered with factory installed output transformers. This option provides ten transformer balanced outputs with D3M output connectors. The balanced outputs provided are:

- L Stereo
- R Stereo
- Mono
- Monitor
- Aux
- Effects Hi
- Subgroups 1,2,3,4.

Earlier C-12 units are not retrofittable.

The transformer balancing assembly is also available as a separate item. This will allow earlier C-12 units to have balanced outputs, however the unit can not be mounted internally as is the factory installed option. The assembly consists of five transformers mounted in a steel case with $\frac{1}{2}$ in. phone jacks for inputs. Output connections are on male XLR (D3M) connectors. Interconnect cables are NOT provided. Two such units are required to fully balance a C-12 mixer.

OF LONG LINES AND MIXERS

True or False?

1. Low impedance lines are always balanced.
2. Balanced lines are the only way you can send an audio signal down a long cable.
3. Phone jacks are high impedance.
4. Cannon connectors are always balanced.
5. Audio transformers have no place in a state of the art audio system.

Count one wrong answer for each question marked True. Every one of the above statements is at least partially wrong.

IMPEDANCE AND BALANCING

Low impedance lines are not always balanced. In common practice, most low impedance microphone lines are balanced. A high impedance line can be either balanced or unbalanced. Likewise, the same applies to low impedance lines.

Balanced lines are not the only way you can send an audio signal down a long cable. An unbalanced line can be equally effective.

THE THREE BASIC PROBLEMS

There are three basic problems in sending an audio signal down a piece of wire:

1. Loss of frequency response due to cable capacitance
2. Induced interference
3. Ground loops

CABLE CAPACITANCE AND SOURCE IMPEDANCE

The first problem is caused by the cable capacitance and the source impedance of the device driving the line forming a low pass filter. All cables have a characteristic capacitance. This is a spec found in most wire manufacturers catalogs. For example, Belden 8774 and 8412 both have a capacitance of around 30 pf per foot. (8774 is 9 pair snake cable and 8412 is heavy rubber mike cable.) When used in a 25000 ohm circuit (typical high impedance), the high frequency response will be 3 dB down at 2122 hz for a typical 100 foot run. Under the same conditions, but with a 150 ohm (typical low impedance), the -3dB frequency will be 354,000 hz. Looking at this from another standpoint, the longest possible cable length for the two given impedances will be: (-3dB at 20khz)

25000 ohms: 10.61 feet

150 ohms: 1768.39 feet

Note that no mention of balanced or unbalanced has been made. The important thing here is IMPEDANCE.

The same thing applies to mixer outputs. What is important here is the actual source impedance. As above, the lower the source impedance, the longer the cable length possible. For TAPCO mixers, it is typically less than 150 ohms actual. Thus, the same figures as used for the microphone examples above apply here. NOTE: The 150 ohm actual output impedance of the mixer does not mean that you should attempt to terminate (load) it with 150 ohms, or that you need an impedance matching transformer. The reason is that the mixer has sufficient voltage output capability to drive the succeeding input to its rated level.

INDUCED INTERFERENCE

The second problem is that of induced interference. For microphones, signal levels are typically very low. Any induced interference (like RF, or hum from an adjacent power cable), will probably be very close in level to that of the microphone. As a result...loud interference. There are two ways around this problem. The first (and definitely not the most practical) is to increase the microphones output. An easy way is to have the performer sing very loud. This increases the mic signal over the interference and improves the signal to noise ratio. Another is to use a preamp right at the microphone and send the signal to the mixer at line level. The easiest and most common practice is to make the mixer input balanced. This allows the mixer to discriminate between the wanted (microphone) and unwanted (noise) signals. Presto! Silence....

An increasingly common practice today is the elimination of the microphone input transformer. Various claims have been made for the multitude of transformerless microphone preamps. Some of these include lower noise, better transient response, lower distortion, more of the good stuff, less of the bad stuff and so on. Apart from noise and distortion, a good many of these folks fail to make any mention of their circuits CMRR (Common Mode Rejection Ratio). CMRR is the ability of a balanced circuit to make the distinction between the good stuff and the bad stuff (noise, interference, etc.). It is fairly easy to achieve a good CMRR number at 60Hz. But what about the broadcast band, citizens band or TV. The mark of a good transformerless input circuit is good CMRR, at least through the broadcast band (1.5MHz). In lieu of this, controlled frequency response rolloff at RF frequencies is very good insurance against RFI. This is the approach taken in the TAPCO Series 72 and 74 mixers. Even the sleaziest of input transformers will act as a reasonable barrier to RF interference, but some of the best transformerless input circuits have absolutely no RF proofing.

For line level signals, induced noise is much lower in level than the actual signal. Hence, an already higher signal to noise ratio. For most applications, balancing at this point is unnecessary. The source impedance of the sending device (mixer, eq, limiter, crossover, etc.) is the important thing and should be 600 ohms or less.

Balancing does have its place on mixer outputs. In a situation where there is a voltage difference between the mixer ground and power amplifier grounds, a current will flow between them and induce hum in the system. In a balanced system, the ground can be floated between the two units to eliminate the hum. This breaks the current path and eliminates the hum. Unfortunately, not all balancing systems in current use will allow this with complete success. Systems using TRANSFORMERS for output balancing will, however. It is usually preferable to break the ground connection at the sending end. A simple cure that can be just as effective is to float the mixer power line ground from the AC power line ground and/or get mixer AC power from the same outlet as the power amps.

In a no room for error situation, the use of transformers for output balancing is first choice. The same applies where the end user has limited knowledge of troubleshooting techniques. Here the use of transformers is just additional insurance against problems. In a maximum performance system, you must weigh the advantages of transformer coupling against their performance limitations. In commercially made transformers, this is a very real economic problem as the cost of a good transformer rises sharply as you attempt to get 20 hz performance that equals the 100 hz or 1000 hz performance.

For example: These units are representative of the state of the art in audio transformer design. Naturally, they could be improved upon by throwing copious amounts of money in the direction of the manufacturer. But then, nobody could afford them!

	Sample 1	Sample 2
20 hz max level, dBm (mfgr spec)	+22	+24
THD, 20 hz, -22dBm	.20%	.36%
20 hz, +18dBm	.18%	1.1%
100 hz, -22dBm	.038%	.21%
100 hz, +18dBm	.012%	.10%
price 1 pc	\$27.00	\$19.00

First, look at the 100 hz number. Nice and low, just as everyone has been conditioned to look for. Now look at the 20 hz numbers. To most users, these figures would seem inferior, after all, isn't good audio equipment supposed to have less than .05% THD across the band? A conservative manufacturer would probably spec a unit using these transformers from 50 to 20 khz and give the worst case distortion over that range. Another may not be so honest (in the interest of sales) and spec the unit from 20 to 20 khz (after all, isn't that what we can hear?) and just give the 100 or 1 khz distortion number (after all, it is below .05%).

SUMMARY

Balanced inputs and outputs can be very effective in minimizing the effects of induced and RF interference. Ground loops are most effectively dealt with in a transformer coupled system. Equally or more important in the case of RF

interference is careful design of the entire product to minimize or eliminate the effects of RF interference.

CONCLUSIONS

1. To send an audio signal down a long piece of wire without loss of high frequency response: LOWER THE SOURCE IMPEDANCE.
2. To minimize the effects of induced interference into a given run of cable: BALANCE THE CABLE RUN AND/OR RAISE THE OPERATING LEVEL.
3. In a no margin for error system (it must work every time or I don't have time to be hassled): USE A TRANSFORMER FOR OUTPUT BALANCING. Carry ground lift adaptors for both AC and audio. You can build an audio ground lift adaptor inside a Switchcraft S3FM shell. Tie pin 2 to pin 2, pin 3 to pin 3 and leave pin 1 open.
4. In systems to be operated by relatively non-technical users: USE TRANSFORMERS.
5. If maximum performance is the goal (over all others): ELIMINATE THE TRANSFORMER.
6. In fixed static installations, transformerless balanced outputs are very effective. The installer must be VERY familiar with good grounding and shielding practices.
7. Given a very technically competent user, transformerless balanced outputs will work well in almost any situation, live or otherwise.
8. When in doubt, use a transformer.
9. The words cheap and good are mutually exclusive to a transformer manufacturer.

BIBLIOGRAPHY

BOOKS

1. THE AUDIO CYCLOPEDIA Howard Tremaine c1969 Howard W. Sams Co. Indianapolis
Audio from A to Z. Good general treatment of a wide range of subjects. Not too technical, minimum use of math. Encyclopedia format.
2. SOUND RECORDING John Eargle c1976 Van Nostrand Reinhold Co. New York
Covers physical aspects of sound, hardware, signal processing and the multi-track recording process. Textbook style. Some math but limited to simple equations. An excellent treatment.
3. THE RECORDING STUDIO HANDBOOK John Woram c1976 Sagamore Publishing Co.
18 chapters covering the art of recording from the Decibel to the Mixdown session.
4. THE TECHNIQUE OF THE SOUND STUDIO Alec Nisbett c1972 Communications Arts Books
New York city 10016 (originally published in Great Britain)
Written with emphasis toward television, film and radio sound. Good attention to detail. Has chapters on sound effects, musical balance, speech balance, microphones and technique, tape editing, film sound editing and more.
5. ACOUSTIC TECHNIQUES FOR HOME & STUDIO F. Alton Everst c1973 Tab Books
If you are thinking about building a studio, building a studio or have built a studio, BUY THIS BOOK. A veritable wealth of information. (Cheap too!)
6. SOUND REINFORCEMENT an anthology of articles from the Journal of the Audio Engineering Society. c1978 Audio Engineering Society Inc.
Coverage leaning toward commercial sound reinforcement rather than musical reinforcement. Good selection of articles. Some of Don Davis's early papers on room-sound system interfacing. Some of the articles are very technical.
7. MICROPHONES an anthology of articles from the Journal of the Audio Engineering Society. C1979 AES Inc.
More design oriented than usage oriented. Papers cover some of the 'classic' microphones still in use today. Technical.
8. SOUND SYSTEM DESIGN Don and Carolyn Davis. c1975 Howard W. Sams Co.
Don and Carolyn Davis are the guiding forces behind Syn-Aud-Con, a sound system design seminar. Sound System Design is the course textbook. For anyone considering installing a sound system in a room, this is the book. Covers room acoustics, loudspeaker array design for a given room, electronic considerations, installation practices and more. Good reference book.
9. MICROPHONES-DESIGN AND APPLICATIONS Lou Burroughs c1974 Sagamore Publishing Co.
26 chapters covering all aspects of microphones written by one of the founders of Electro-Voice. Good coverage of the basics of good microphone usage.

Some of the above books are available from: dB Bookcase
Sagamore Publishing Co.
1120 Old Country Rd.
Plainview, Long Island, NY 11803

MAGAZINES

1. RECORDING ENGINEER/PRODUCER published bi-monthly (6 iss/yr) by Gallay Communications Inc. POB 2449 Hollywood CA 90028. \$10/year.
Interviews, equipment, new products, technique and much more. THE BEST
2. STUDIO SOUND monthly, subscription department, Link House, 25 West St., Poole, Dorset BH15 1LL, Great Britain. Sent free to qualified readers. Tied with REP for #1. The absolute best equipment reviews in the business. Hugh Ford (equipment reviewer) is a master at devising fiendish tests designed to ferret out the shortcomings (if any) in any piece of audio equipment. Good articles every month on all aspects of sound.
3. MODERN RECORDING and MUSIC monthly, Cowan Publishing, 14 Vanderventer Ave, Port Washington NY 11050. \$12/yr
Aimed primarily at today's musician/performer/songwriter/engineer. Good articles, equipment reviews (but not nearly as thorough as Studio Sound's). Good tutorial series on basic electronics.
4. SOUND ARTS Sound Arts Merchandising Inc, 220 Westbury Ave. Carl Place, NY 11514
Aimed primarily at the music retailer and geared toward staying current on the new wave of music instrument electronics and the sophisticated consumer of the 80's.
5. JOURNAL OF THE AUDIO ENGINEERING SOCIETY (JAES) monthly except Jan/Feb and Jul/Aug. Free to members of any grade, \$45 to nonmembers.
State of the Art papers on all phases of audio engineering. Papers are written by professionals in audio engineering and are usually presented at one of the society's 3 yearly conventions (February-Europe, May-Los Angeles, November-New York). Highly technical, written at engineering level. i.e. Don't spare the math.

Membership in the society is open to anyone with an interest in audio engineering. There are 3 membership grades: Member, Associate and Student. Dues vary with membership grade. A subscription to the Journal is part of the yearly dues. Contact: Audio Engineering Society, Lincoln Building, 60 E 42nd St. New York NY 10165. (212) 661 2355
6. dB the SOUND ENGINEERING MAGAZINE. monthly, \$9/yr Sagamore Publishing Co.
Product oriented coverage. Occasional good articles. Excellent monthly columns by George Alexandrovich and Norman Crowhurst.

COURSES AND SEMINARS

Syn-Aud-Con, POB 1115, San Juan Capistrano CA 92693 714 496 9599
Commercial Sound System design seminars and consulting.

Recording Institute of America (RIA) 220 Westbury Ave, Carle Place NY 11514
10 week course in modern recording techniques held locally in a 16 track studio.
Classes held in many cities of the US and Canada.

University of Miami, School of Music, Coral Gables FL 33124. Complete degree program with emphasis on music, technique and electronics.

Mention of the above programs does not constitute endorsement by TAPCO. Many other colleges and universities offer similar courses. Additional information is also available from the AES.