

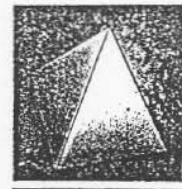

Electro-Voice®
INTERFACE
MODULAR CONSOLES



MARK IV AUDIO

OWNER'S MANUAL

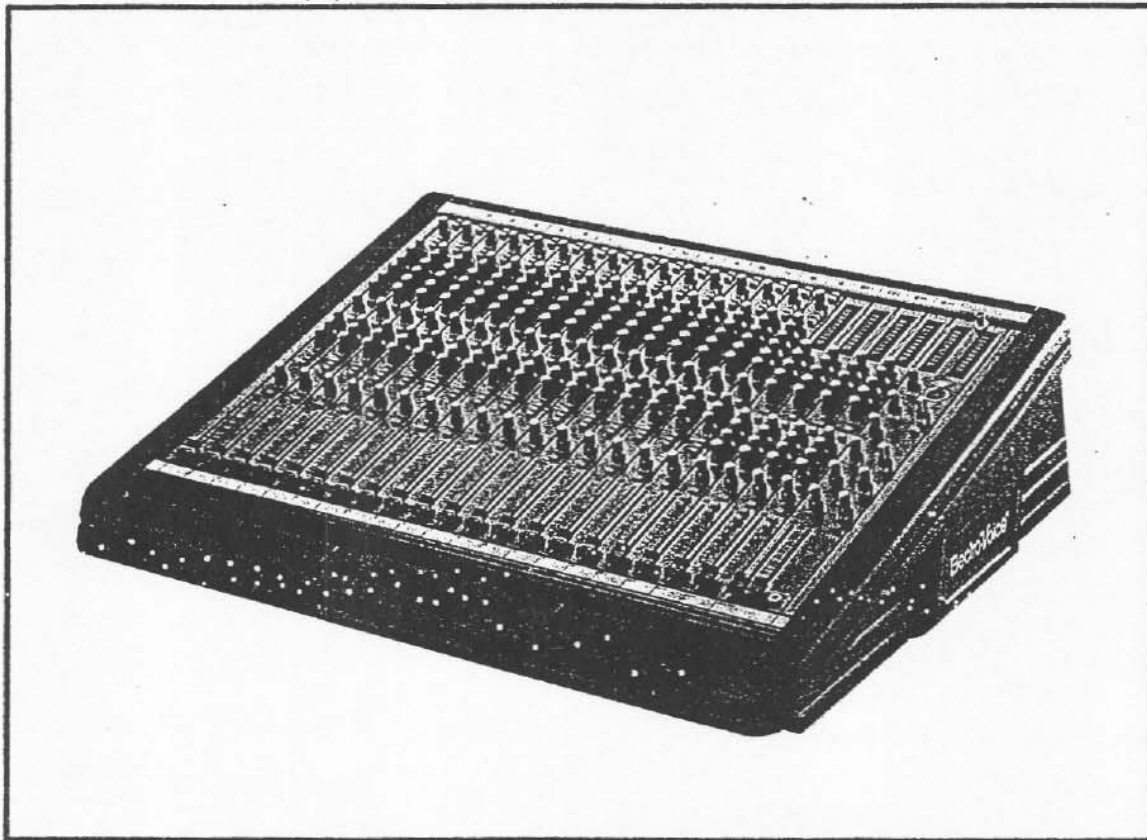

1. INTRODUCTION AND INSTALLATION

1.1 Introduction

Congratulations! You are now the owner of an INTERFACE Console. This manual has been written to help you get the most out of working with your new mixer, and covers installation and operation.

INTERFACE is a fully modular 4 Group console. It may be configured according to the application by the selection of different input and output modules. If desired, INTERFACE may be used with no Group output modules, simply Inputs and the Master Output.

This flexibility is ensured thanks to the modules having integral connector assemblies, which allow not only their placement almost anywhere within the frame, but the addition of other and new modules as they are introduced, without the need for modifications. However, to protect your Warranty, only authorised INTERFACE Dealers should replace or add modules to your console.

INTERFACE is designed to grow with you in the future. We thank you for your purchase, and hope you will enjoy being a part of the Worldwide INTERFACE User Group.

1.2 Safety Precautions

1.21 Safety Precautions

IMPORTANT - PLEASE READ BEFORE INSTALLING YOUR INTERFACE CONSOLE.

- * Strong sources of electromagnetic radiation (eg high power cabling, video monitors, radio transmitters) may cause degradation of the audio quality due to induced voltages in the chassis and connecting leads. Site the console away from such sources. For the same reason, it is advisable to site the power supply away from the console.
- * Electronic components are susceptible to conditions of excessive heat or extreme cold, so take care not to use your INTERFACE console under such conditions.
- * Before powering up the console, make sure that the Power Supply voltage selection matches the local mains supply.
See the chart in Section 4 for the correct settings.
- * NEVER connect or disconnect the console power cable without first switching off the power supply. Similarly, switch off before removing or servicing modules.
- * Do not attempt to wipe clean the console with a cleaning liquid. Most surfaces can be simply cleaned with a soft dry brush. Should the chassis or channel ident strips need cleaning, use only water or an alcohol. Solvent-based products should not be used as they will damage these parts.
- * If you spill any liquids inside the console (eg coffee on the faders), switch off the power unit immediately. Consult your Authorised Dealer before attempting any cleaning.

1.22 Transport

We recommend that you retain all the packing from your INTERFACE console should you ever need to return it for service, or move the console to other premises.

If the console has to be moved regularly, then we suggest that you purchase a foam-lined flight-case, available from your Distributor if you cannot source one locally.

1.3 Power Supplies and cabling

Only use the power supply and cables provided. Your warranty is invalidated if other supplies or cables are used.

Consoles requiring up to 3.5 amps DC are powered by INTERFACE POWER SUPPLY PSI 2835.

If you experience any problem with the local mains, or during thunder storms, switch off the power supply and unplug it from the mains supply.



1.4 Input and Output Specifications/Features

CONNECTION	TYPE		+	-	-	Load/Source Impedance	Gain Range	Nominal Operating Level	For Use with Nominal	Max Input before clip.	Max Output before clip.	Special Functions
MIC INPUT	XLR-3F	Bal #1	2	3	1	>1.6 kOhm #2	6 dB >76 dB	-2 dBu > -72 dBu	150-200 Ohm Mics	+13 dBu		20dB Pad, HPF, Phase Reverse
LINE INPUT	JACK	Bal	Tip	Ring	Sleeve	>20 kOhm #3	-10 dB >+20 dB	+14 dBu > -16 dBu	600 Ohm Line	+28 dBu	+20 dBu	Phase Reverse, HPF
INSERT SEND	JACK	Unbal			Sleeve	75 Ohm		-2 dBu	600 Ohm	+22 dBu		
INSERT RETURN	JACK	Unbal	Tip			10 kOhm		-2 dBu	600 Ohm	+22 dBu		
DIRECT OUTPUT	JACK	Gnd Comp	Tip	Ring	Sleeve	75 Ohm		-2 dBu	600 Ohm	+22 dBu	+22 dBu	Direct and via AUX 1
TAPE RET. L/R	JACK	Bal	Tip	Ring	Sleeve	>22 kOhm		+4 dBu / -10 dBV	600 Ohm	+27 dBu		
AUX OUTPUT	JACK	Bal #1	Tip	Ring	Sleeve	75 Ohm		+4 dBu	600 Ohm	+22 dBu		
GROUP OUTPUT	XLR-3M	Bal #1	2	3	1	75 Ohm		+4 dBu / -10 dBV	600 Ohm		+25 dBu	
MIX OUTPUT L/R	XLR-3M	Bal #1	2	3	1	75 Ohm		+4 dBu / -10 dBV	600 Ohm		+27 dBu	Output Turn-On delay
C/R MONITOR OUTPUT	JACK	Gnd Comp	Tip	Ring	Sleeve	75 Ohm		+4 dBu	600 Ohm		+22 dBu	
TALKBACK MIC INPUT	XLR-3F	Bal	2	3	1	>1.6 kOhm	-6 dB >+46 dB	-42 dBu > +10 dBu	150 > 600 Ohm Mics	+13 dBu		Phantom power link
HEADPHONE OUTPUT	JACK	Stereo	Tip-L	Ring-R	Sleeve	75 Ohm		160 mW #4	8 > 600 Ohm		+20 dBu #4	
RETURN A/B	JACK	Bal	Tip	Ring	Sleeve	>22 kOhm		+4 dBu / -10 dBV	600 Ohm	+27 dBu		
MIX OUTPUT MONO	XLR-3M	Bal #1	2	3	1	75 Ohm		+4 dBu / -10 dBV	600 Ohm		+25 dBu	Output Turn-On delay

- Notes:
- Bal - Electronically Balanced
 - Unbal - Unbalanced
 - Gnd Comp - Ground Compensated
 - All JACKs are 1/4" A Gauge, three pole
 - #1 Transformer Balancing Option
 - #2 >1.6 kOhm with transformer
 - #3 >10 kOhm unbalanced
 - #4 RL = 2 x 600 Ohm

INPUT/OUTPUT SPECIFICATIONS CHART

INTERFACE TECHNICAL SPECIFICATIONS

Measured on 16 Channel Console:
16 x 2802 / 4 x 2808 / 1 x 2810

DISTORTION (THD)

	1kHz	10kHz
Input to Mix Output	0.005%	0.02%
Input to Group Output	0.005%	0.02%
Input to Aux Output	0.008%	0.06%

CROSSTALK (16 Channels routed)

Channel Muting	> 95 dB	> 75 dB
Maximum Fader Attenuation	> 100 dB	> 90 dB
Panpot Isolation	> 70 dB	> 65 dB
Routing (Channel to Groups)	> 80 dB	> 75 dB
Maximum Aux Send Attenuation	> 90 dB	> 90 dB
Mic Input at Max Gain, CMRR	> 80 dB	
Line Input at Unity Gain, CMRR	> 45 dB	

NOISE

Measured 22Hz to 22kHz Bandwidth, unweighted

Mic Input at Max Gain, EIN with 150 Ohm source	- 127.5 dBu
Line Input at Max Gain, EIN with 50 Ohm source	- 92 dBu
Mix Bus Noise (Fader Down)	- 79 dBu
Typical Mix Output Noise	- 75.5 dBu
Aux Bus Noise	- 75 dBu

FREQUENCY RESPONSE

Mic or Line Input to any Output (20 Hz ... 20 kHz)	+ 0 dB / - 0.5 dB
--	-------------------

INPUT & OUTPUT IMPEDANCES

Mic Input	> 1.6 k Ohm
Line Input	> 10 k Ohm
Inserts Sends	75 Ohm
Inserts Returns	> 10 k Ohm
All Outputs	75 Ohm

INPUT & OUTPUT LEVELS

Mic Input Max Level PAD off:	+ 13 dBu
Mic Input Max Level PAD on:	+ 33 dBu
Line Input Max Level	+ 28 dBu
Inserts Sends Max Output Level	+ 20 dBu
Inserts Sends Nominal Output Level	- 2 dBu
Direct Output Max Level	+ 22 dBu
Direct Output Nominal Level	- 2 dBu
Group Output Max Level	+ 25 dBu
Group Output Nominal Level	- 10 dBV/ + 4 dBu
Aux Output Max Level	+ 22 dBu
Aux Output Nominal Level	+ 4 dBu
Mix Output Max Level	+ 27 dBu
Mix Output Nominal Level	- 10 dBV/ + 4 dBu
Mix Insert Nominal Level	- 2 dBu
Mono Output Max Level	+ 25 dBu
Mono Output Nominal Level	- 10 dBV/ + 4 dBu
Internal Operating Levels	- 2 dBu
Headphones Output Max Level into 600 Ohm	+ 20 dBu
Headphone Output Nominal Level	+ 14 dBu
Tape Return Nominal Level	- 10 dBV/ + 4dBu
Tape Return Maximum Level	+ 27 dBu

1.5 Console Terminology

This section provides a simple explanation of some of the terms used when describing the console features.

1.51 Glossary of Terms

Auxiliary Sends

These are extra signal paths out of the console, separate from the main outputs, such as the stereo mix or sub-groups. Each auxiliary send is like an input to a separate mixer, independent of the main mix on the channel faders. They are used to provide special mixes to artists as they are recording (in which case they are normally called FOLDBACK sends) or as a mix of signals sent to an effects unit such as a reverb or delay.

Bus

This is the term used to describe the summing or mixing of a number of signals. A number of inputs routed to the same 'bus' will appear as one signal at the output of that bus.

Routing

The sending or 'assignment' of a signal to a 'bus', normally by a routing switch. Signals may be routed to several buses simultaneously, or to just one if desired (for example the stereo mix).

Line Input

A high-level signal, normally coming from equipment such as tape machines, synthesisers and effects devices. Professional equipment normally gives output levels of +4dBu (ie +4dB ref 0.775V, or 1.228V), although some semi-professional and most 'domestic' equipment only give an output of -10dBV (ie -10dB ref 1V, or 300 mV).

Monitor

Monitors the output of a mixer or tape machine independently of the actual output of the desk. It allows you to listen to alternative sources while the actual mix is in progress.

Foldback

See Auxiliaries

Insert Point

Breaking the signal path in a channel so that an external piece of equipment may be 'inserted' in the path to process the channel signal.

Send

The output from a channel insert is often called the SEND, as is the feed to a tape machine for recording from a sub-group.

Return

Any signal that comes back from a piece of equipment is called a return. It could be from a device used in the insert, or a signal from a track of a tape machine, or the output of an effects device connected to an auxiliary output.

XLR Connector

The XLR (in fact a specific manufacturers model reference) is an industry standard connector of high quality and is normally used for balanced signals, primarily microphones and balanced outputs. The most common is a 3 pin version, although there are types with more pins for other purposes.

'A' Gauge Jack

This is one standard of 1/4" jack connector. Be careful to match your plugs and sockets to the correct standard.

Talkback

When the engineer at the console wishes to talk to the artist in the studio or check out external system connections, he can talk through the system via a local microphone.

Oscillator

A tone-generator used for checking signal paths and putting test tones to the tape machine.

PFL

PFL is one of two SOLO modes. It sends the selected signal to the monitor system so that it can be monitored without affecting the actual output of the console (the stereo mix, for example). PFL stands for PRE FADE LISTEN, so signals are taken from before the fader and therefore are unaffected by fader position.

AFL

The AFL solo mode is AFTER FADER LISTEN, so the monitored signal is affected by the fader setting. Again this is only on monitoring, and the console main outputs are unaffected.

Master

This normally refers to the main stereo output section, which controls the level of the stereo mix, and associated functions such as monitoring.

Pan

When a mono signal is fed to the stereo mix or a pair of buses, the PAN control determines how much of the signal is sent to those buses. When set fully one way, full signal is sent to one bus, and none to the other. When set centrally, equal amounts of signal are sent to both buses. In the centre, the signal is reduced by an amount, normally about 4.5dB, to provide an approximately constant loudness when the signal is panned across the stereo image.

Shelving EQ

If an equaliser is described as shelving, it means that the response and gain becomes constant after the 'break-point', so a high-frequency shelving EQ at 10kHz will have an increasing output as the frequency approaches 10kHz, but flat above 10kHz. This type is normally found on the HF and LF sections of the equaliser.

Peaking EQ

Another type of EQ is 'peaking', where the response is tailored to enhance a selected band of frequencies in relation to frequencies above and below it. These are normally used in mid-band sections.

Q (Bandwidth)

Associated with peaking equalisers, the Q is a factor which describes how wide the 'peak' of enhancement is. The lower the Q factor, the wider the bandwidth of the equaliser will be. The mid range sections of the INTERFACE equaliser have a Q of 1.5, which equates to a bandwidth of about 1 octave.

Sweep Frequency

A control which selects a centre frequency to operate around. Most often used with peaking equalisers, but can be used to adjust the roll-off point of shelving EQ's as well.

High Pass Filter

A filter which cuts out very low frequencies, normally 80Hz and below, used to filter out noises picked by microphones on stage (floor noise) or video camera buzzes etc.

1.6 WARRANTY

Your Interface Console is guaranteed from the date of purchase against malfunction due to defects in materials or faulty workmanship for three years.

If such malfunction appears during the specified period, the product shall be returned to the Distributor or the Manufacturer and subject to the following conditions: the Distributor or Manufacturer will repair or at its option replace the defective components free of charge.

This warranty is only valid if:

- * The equipment has been installed and used in accordance with the directions given by the Manufacturer in this manual; and
- * Any defects has been notified to the Distributor or Manufacturer within 14 days of the defect appearing; and
- * Only Authorised Service agents of the Distributor or Manufacturer make repairs to the equipment.

Excluded from this warranty are defects caused by Faulty or negligent handling; Accidental damage; and Acts of God.

The Manufacturer shall not be liable for any damage caused to persons or property due to:

- * Incorrect usage of the equipment, or
- * Other equipment attached to the Interface console, which the Manufacturer considers unsuitable, or
- * Modifications or repairs made by non-authorized persons, or using non-recommend or incorrectly made parts.

The replacement of certain electro-mechanical parts under this warranty shall be at the discretion of the Manufacturer or Distributor.

All postage and/or freight charges in connection with the return of the Equipment (both to and from the Distributor or Manufacturer) must be pre-paid, and whilst in transit goods will be at the risk of the End User. Benefit of this warranty may not be assigned by the End User. Your statutory rights are not affected by this warranty.

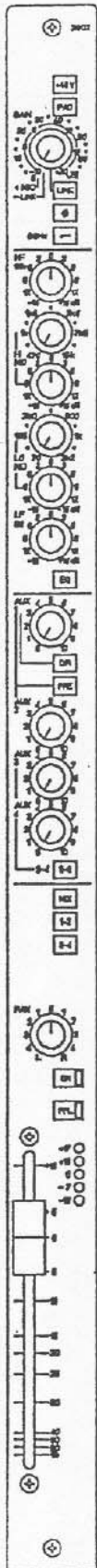

2. MODULE DESCRIPTIONS

2.1 Input Module 2802

The Input Module, type 2802, is provided with rear panel connectors for Microphone (on XLR), and Line (Jack) inputs, both balanced. Insert send and return signals are available on a single stereo jack socket, and are unbalanced. A Direct output, unbalanced ground-sensing, is also available via a jack socket on the rear panel.

Wiring of the Jacks follows normal conventions, so that compatibility with existing cables is provided where possible.

Blanking panels are fitted to the main chassis to allow the fitting of multiway connectors. Consult your Authorised Dealer for more information.

All balanced XLR inputs are wired to the International standard of Pin 2 hot. If you need to connect unbalanced equipment to inputs or outputs, wire the cold terminal to pin 3 for XLR's, or Ring for jacks.

The microphone input is suitable for use with balanced, low-impedance (150 or 200 ohm) microphones.

*** Do not use dynamic, unbalanced, or battery powered - microphones with the +48 volt phantom power switched on: damage to the microphone may result.**

The gain of this section is variable from 6dB to 76dB, to give an output of +4dBu at the stereo mix outputs. This corresponds to a sensitivity of -2dBu to -72dBu. With the gain control at minimum, the maximum input level is +14dBu without the 20dB pad.

The gain of the line input may be adjusted from -10dB to +20dB, corresponding to a sensitivity of +14dBu to -16dBu to give an output of +4dBu at the stereo mix outputs.

The impedance of the line input is approximately 20kOhms, so instruments with high impedance outputs, such as electric guitars, are best fed through a DI box to the microphone input, to avoid being loaded down by the line input impedance.

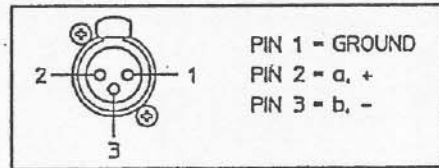
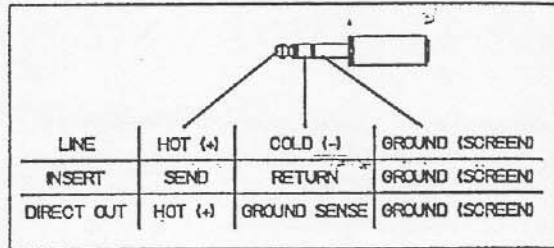

CONNECTOR PANEL



2.11 Module Functions

Channel Input

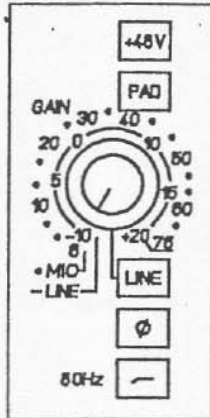

+48V

Provides 48 volt phantom power for a condenser microphone, or DI box. DO NOT use the phantom supply with Dynamic microphones. Optional balancing transformers may be fitted on the Mic input.

PAD

Switching in PAD inserts a 20dB attenuator in circuit with the microphone input. This may be used when high-output microphones are employed, or to enable the use of the mic input for line-level signals.

GAIN

The gain control is a wide range rotary potentiometer, and is active on both Mic and Line Inputs. On Mic, the gain can be adjusted from 6dB to 76dB. For Line inputs, the adjustment is from -10dB to +20dB.

LINE

The LINE switch selects the signal on the line input socket to feed the channel path when it is down. In this case, the Mic signal is disconnected.

∅

The PHASE REVERSE (∅) switch inverts the phase of the selected input, Mic or Line, to allow compensation for different wiring standards.

Filter

The Filter switch inserts a 80Hz highpass filter with a rolloff of 12dB per octave into circuit after the input amplifier. This may be used to eliminate unwanted low-frequency noises such as rumble, or camera buzz.

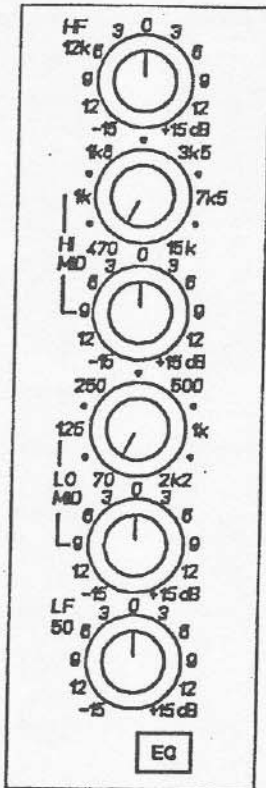

Equaliser

The equaliser on the Input Module is a four band design, incorporating two sweepable peaking mid-range sections, and fixed-frequency shelving high and low controls.

HF

Shelving section, providing ± 15 dB of gain at 12kHz.

HI MID

Peaking section, providing ± 15 dB of gain, at frequencies from 470Hz to 15kHz.

LO MID

Peaking section, providing ± 15 dB of gain, at frequencies from 70Hz to 2.2kHz.

LF

Shelving section, providing ± 15 dB of gain at 50Hz.

EQ IN

The EQ switch inserts the entire equaliser circuit into circuit. When switched out, the equaliser is totally bypassed, keeping the signal path to a minimum.

The Insert point is located after the EQ section.

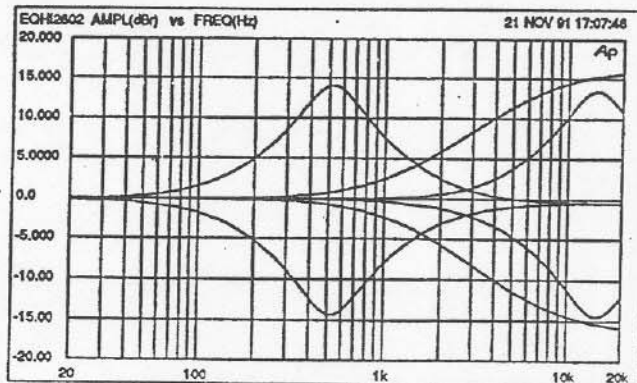
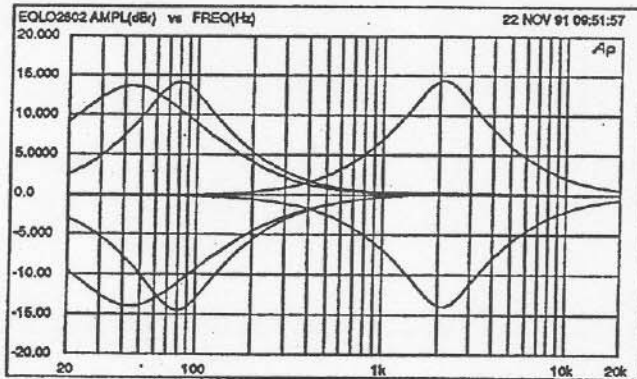

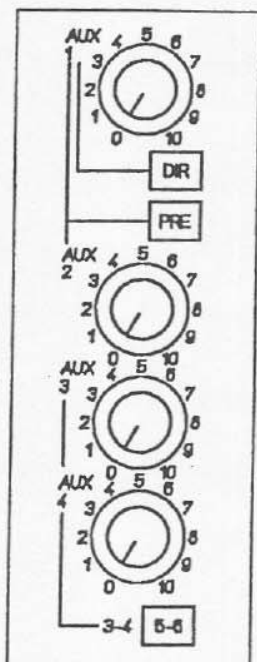

Auxiliaries

The Interface console has six auxiliary buses, accessed on the Input module from 4 controls. In addition, the channel direct output may be controlled via one pot, to provide extended auxiliary sends.

AUX 1

Controls the level of the channel signal fed to the Aux 1 bus. This signal is normally post-fader, unless the PRE button, just below, is depressed. Internal links allow the pre-fader feed to be pre- or post-EQ.

DIR

Re-routes the signal on the Aux 1 control to feed the Channel Direct output. The signal no longer feeds the Aux 1 bus, and can be used either as an additional single effects send, or as a feed to a multitrack, for example.

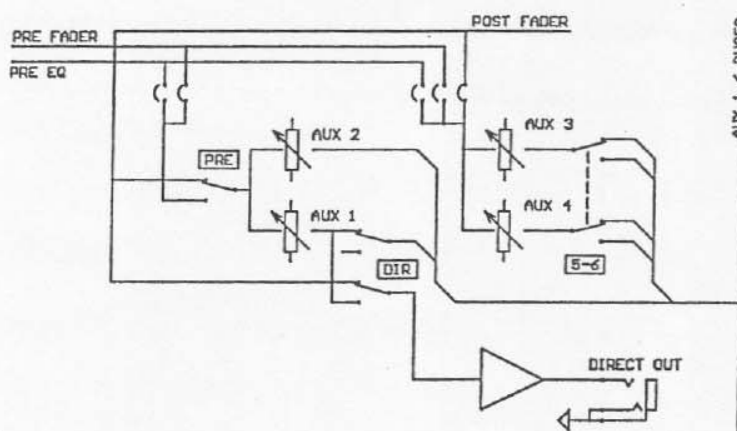

PRE

Feeds the Aux 1 and Aux 2 controls with a signal taken pre-fader, instead of post-fader. In this case, the signal on the Aux 1 & 2 buses is unaffected by the position of the channel fader.

Internal links allow the pre-fader feed to be pre- or post-EQ.

Aux 2

Controls the level of the channel signal fed to the Aux 2 bus. This signal is normally post-fader, unless the PRE button, just above, is depressed.

Aux 3

Controls the level of the channel signal fed to the Aux 3 bus, and is internally linkable to be pre or post-fader. When the 5-6 switch is depressed, this control feeds the Aux 5 bus instead of the Aux 3 bus.

The pre-fader feed can be taken from before or after the equalizer.

Aux 4

Controls the level of the channel signal fed to the Aux 4 bus, and is internally linkable to be pre or post-fader. When the 5-6 switch is depressed, this control feeds the Aux 6 bus instead of the Aux 4 bus.

Note: DIR, PRE, and 5-6 are local to the module, they do not affect signal flow on any other module than the one on which they are located.

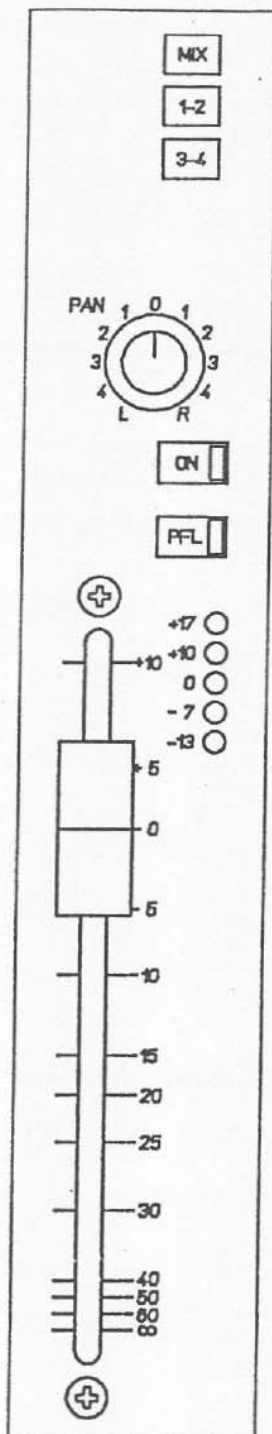

Routing

When any routing button is pressed, the **PAN** control is automatically inserted into circuit across the selected buses, allowing the signal to be positioned in the stereo image. When PAN is set to centre, equal levels are sent to both buses, with a 4.5dB drop relative to fully clockwise or anti-clockwise. Setting the PAN control fully anticlockwise sends full level to the Left/1/3 buses, cutting the send to the Right/2/4 buses; fully clockwise rotation sends full level to the Right/2/4 buses, cutting the feed to Left/1/3.

MIX

Routes the post-fade, post-pan channel signal to the stereo mix bus.

1-2

Routes the post-fade, post-pan channel signal to output buses 1 and 2.

3-4

Routes the post-fade, post-pan channel signal to output buses 3 and 4. Any unused channels should not be routed so as to maximise the performance of the console.

Channel Status

ON

The ON switch enables the channel signal path, and is indicated by an led in the switch when the channel is active. When OFF, all post-fade auxiliary sends and routing assignments are muted. It is best to switch all unused channels off to avoid any noise being added to any parts of the mix.

PFL

The PFL button (or SOLO) feeds the post-EQ, pre-fader signal to the Monitor section (loudspeakers or headphones), replacing the selected monitor source. The main stereo output of the console is not affected. The red led in the PFL switch will illuminate when the PFL function is active. PFL signals from different sources that are active simultaneously will be summed.

SIGNAL METER (led)

A five segment led signal meter shows when signal is present, above a threshold of -13dBu, and will show peak signals up to +17dBu. If the top led is on partly or continuously, the signal is close to clipping, or severe distortion, and the channel gain should be reduced.

FADER

The fader is the main signal level control for the channel, and is a long-throw type which gives smooth control of the channel level.

OPTIONAL LINK SETTINGS

ON P.C.B. 81 285

(*1) Factory preset

J 1 : Selects AUX1/2 Routing
 from PRE FADER (*1) or PRE EQ, when PRE-Switch is depressed

J 2/3/4 : Selects AUX 3/4 Routing
 from PRE EQ or POST FADER (*1) or PRE FADER

J 5 : Selects PFL or AFL
 from PRE FADER (*1) or AFTER FADER

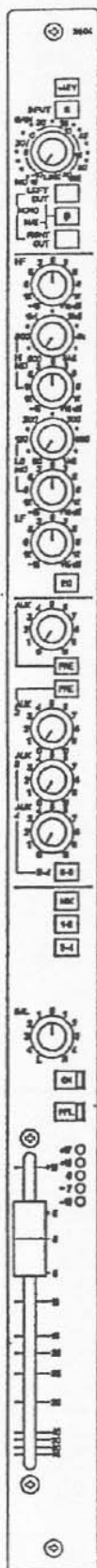

2.2 Stereo Input Module 2804

The Stereo Input module has two stereo input sources. Input A is for a stereo Microphone, while input B is for a line-level stereo input, which can be optionally configured as a phono (RIAA equalised) input by purchasing the RIAA adapter card.

Sum-and-Difference, or MS decoding is provided either at Mic or line level signals using a combination of the mono and phase reverse switches.

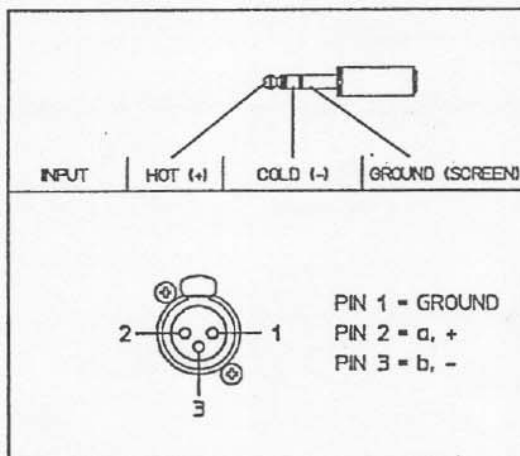

CONNECTOR PANEL

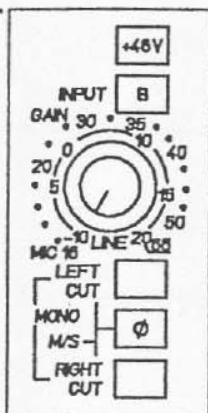

**+48V**

Switches 48 volt phantom power to the Mic input A.

INPUT B

Selects the source on the input B connectors. Normally this is a line input, but may be internally adapted to be a phono input from a turntable using the RIAA adapter (please ask your INTERFACE Dealer).

GAIN

The Gain control is wide range rotary control, and is active on both inputs A and B. On input A (Mic), the gain is adjustable from 16 to 66 dB, while on input B (Line or Phono), the gain range is from -10 to +20 dB.

LEFT CUT

This switch mutes the left channel signal, so only the right channel signal is heard.

RIGHT CUT

This switch mutes the right channel signal, so only the left channel signal is heard.

MONO

When both Left Cut and Right Cut switches are pressed, the input signal is combined to give a mono signal, which is fed to both signal paths through the module.

PHASE REVERSE

Under normal conditions, this reverses the phase of the right channel. If both the CUT switches above are pressed so that the signal is mono, pressing Phase Reverse will allow the input to be used for MS decoding, either from a microphone or line level signal.

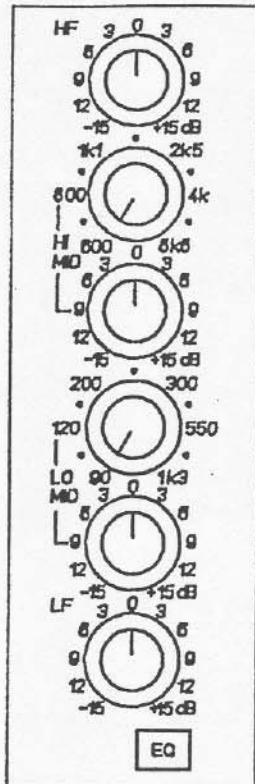

Equaliser

The equaliser on the stereo input module is a four-band design with two swept mids, and shelving high and low frequencies.

HF

Shelving section, providing ± 15 dB of gain at 12 kHz.

HI-MID

Peaking section, providing ± 15 dB of gain, at a centre frequency adjustable from 600 Hz to 8.8 kHz.

LO-MID

Peaking section, providing ± 15 dB of gain, at a centre frequency adjustable from 90 Hz to 1.3 kHz.

LF

Shelving section, providing ± 15 dB of gain at 50 Hz.

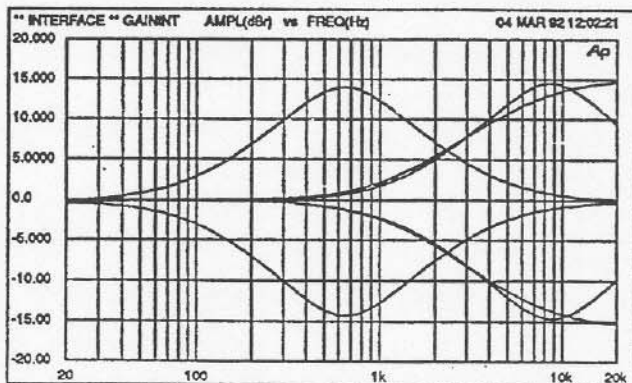
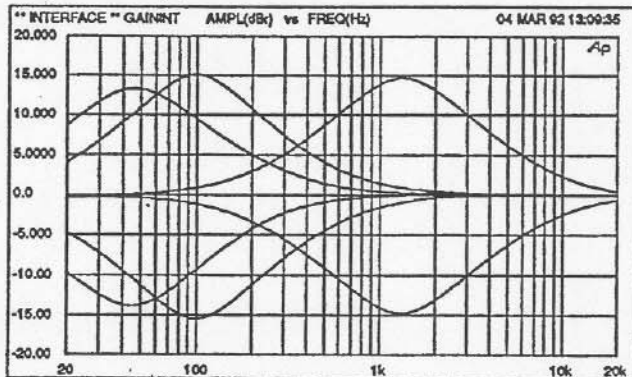

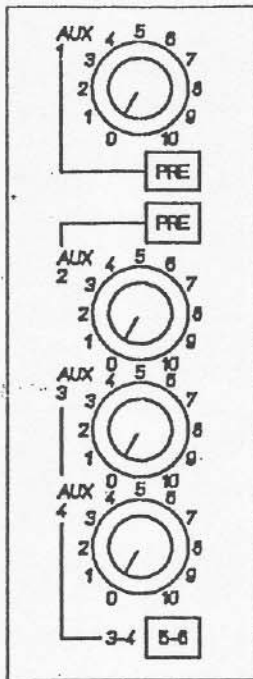

Auxillaries

The INTERFACE console has six Auxiliary buses, accessible on the input module via 4 controls. On the Stereo Input module, the Aux buses are fed from a mono sum of the left and right channels.

AUX 1

Controls the level of the channel signal fed to the Aux 1 bus. This signal is normally post-fader, unless the PRE button just below the AUX 1 control is pressed.

PRE

Feeds the AUX 1 control with a signal taken pre-fader instead of post-fader. In this case, the signal fed to the Aux 1 bus is unaffected by the position of the channel fader.

AUX 2

Controls the level of the channel signal fed to the Aux 2 bus. This signal is normally post-fader, unless the PRE button just above the AUX 2 control is pressed.

PRE

Feeds the AUX 2 control with a signal taken pre-fader instead of post-fader. In this case, the signal fed to the Aux 2 bus is unaffected by the position of the channel fader.

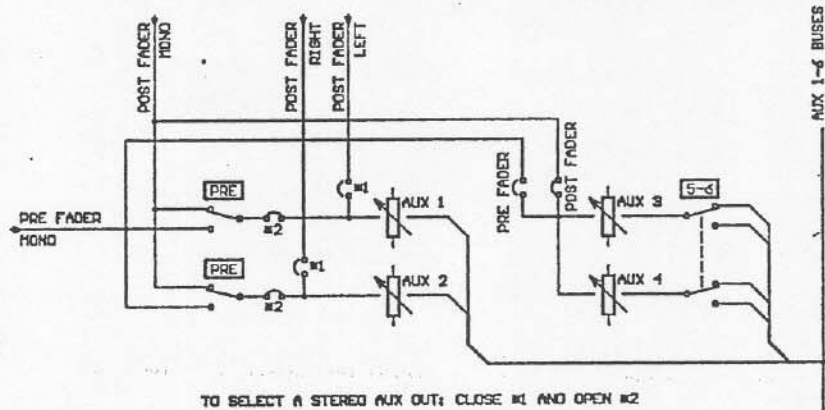

Note: Internal links allow the AUX 1 control to send the left channel signal and AUX 2 the right channel. This gives a stereo AUX output. The signal is post-fader, and the PRE switches then have no function.

AUX 3

Controls the level of the channel signal fed to the Aux 3 bus, and can be linked internally to be pre or post-fader. When the 5-6 switch is pressed, this control feeds the Aux 5 bus.

AUX 4

Controls the level of the channel signal fed to the Aux 4 bus, and can be linked internally to be pre or post-fader. When the 5-6 switch is pressed, this control feeds the Aux 6 bus.

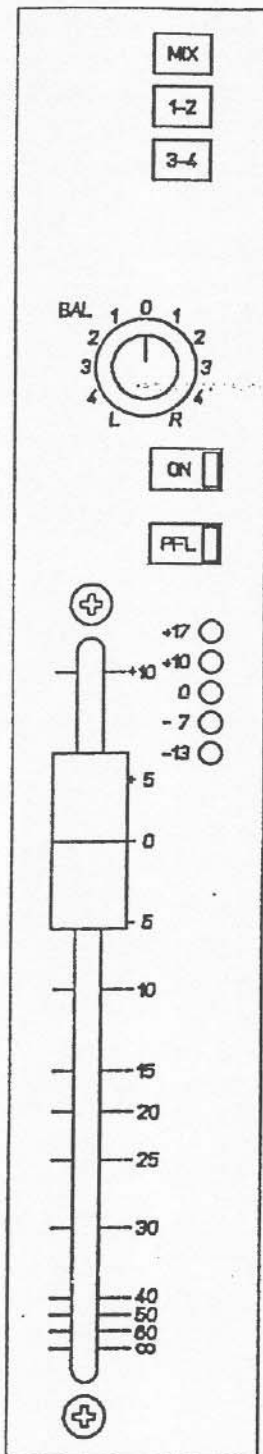

Routing

When any routing button is pressed, the BAL control is automatically inserted into circuit, allowing the signal to be balanced in the stereo image. If the channel is selected to mono (see Left/Right Cut switches) the Balance control will operate in a similar manner to the Pan control on mono inputs, but with a limited range of control ($\pm 3\text{dB}$).

MIX

Routes the post-fade, post-bal signal to the stereo mix bus.

1-2

Routes the post-fade, post-bal signal to output buses 1 and 2.

3-4

Routes the post-fade, post-bal signal to output buses 3 and 4.

BAL

When BAL is set to its centre, equal levels are sent to both buses, with a 3 dB drop relative to fully clockwise or anti-clockwise. Setting the BAL control fully clockwise sends a level of 3dB higher on the right bus and a level of 3dB lower on the left bus.

Channel Status

ON

The ON switch enables the channel signal path, and is indicated by an LED in the switch when the channel is active. When OFF, all post-fade auxiliary sends and routing assignments are muted. It is recommended to switch off all unused channels to avoid additional noise contribution.

PFL

The PFL button (or SOLO) feeds the post-EQ, pre-fader signal to the monitor section (loudspeakers or headphones), replacing the master signal. The main stereo output is not affected. The red LED in the PFL switch illuminates when the PFL function is active. PFL signals from different sources that are active simultaneously are summed.

SIGNAL METER (LED)

A five segment LED signal meter shows when a signal is present above a threshold of -13dBu , and will show peak signals of up to $+17\text{dBu}$. If the top led is on partly or continuously, the signal is close to clipping, or severe distortion. The channel gain should be reduced. The meter shows the higher of the left or right channel signals.

STEREO FADER

The fader is the main signal level control for the channel, and is a long-throw type which gives smooth control of the channel level.

POSSIBLE JUMPER SETTINGS

On pcb 81 286

(*1) Factory pre-set

- J1:** Determines the AUX 3/4 output:
pre-fader or post-fader (*1)

- J2:** selects PFL or AFL
pre-fader listening (*1) or after-fader listening

- J3/J4:** Changes the AUX 1/2 output from 2 x mono (*1) to 1 x stereo
(AUX 1 = left, (J3), AUX 2 = right (J4))
Note! In stereo mode both PRE switches have no function!

2.3 Digital Stereo Input Module 2824

The Digital Stereo Input module accepts any one of 3 analog or 2 digital stereo signal sources. The sound source is selected by electronically latching push-buttons.

Three pairs of phono/cinch (RCA) connectors are provided for the 3 analog signal sources (Phono, CD, Line). Digital signals from CD players and DAT recorders may be fed into the module directly via a coaxial connector or an optical connector.

For the coaxial connector we recommend a 75 ohm cable, and for the optical input a special fibre-optic cable is required (please ask your INTERFACE dealer).

Both Digital inputs process the SPDIF (Sony-Philips Digital Interface) Hi-Fi standard format.

It is possible to internally set which of the inputs is selected when the console is switched on.

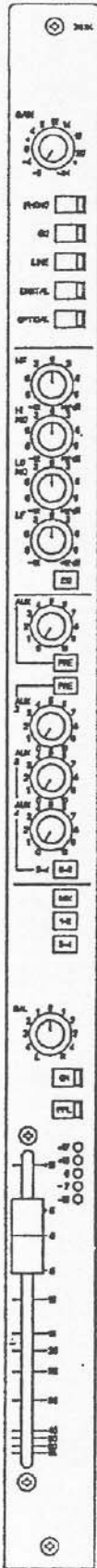

CONNECTOR PANEL



2.3.1 Module functions

GAIN

The gain control is a wide range rotary potentiometer with a range of 30 dB, so that the different output levels of the sources may be adapted to the input.

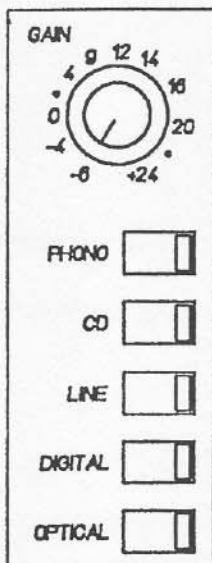

PHONO

The PHONO switch selects a stereo signal from the PHONO input. At the same time a cartridge equalizer (RIAA) is looped into the signal path. When selecting PHONO the other sources are switched off.

CD

The CD switch selects a stereo signal from the CD input. When selecting CD the other sources are switched off.

LINE

The LINE switch selects a stereo signal from the LINE input. When selecting LINE the other sources are switched off.

DIGITAL

The DIGITAL switch selects a stereo signal from the coaxial DIGITAL input. At the same time a D-A converter is looped into the signal path. When selecting DIGITAL the other sources are switched off.

OPTICAL

The OPTICAL switch selects a stereo signal from the OPTICAL input. At the same time a D-A converter is looped into the signal path. With selecting DIGITAL the other sources are switched off.

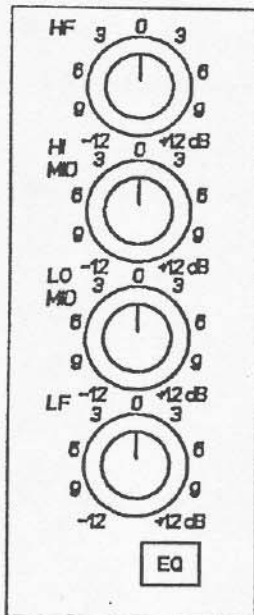

STEREO Equaliser

The equaliser on the input module 2824 is a four-band design with two peaking fixed mid-range frequencies.

HF

Shelving section, providing ± 12 dB of gain at 12 kHz.

HI MID

Peaking section, providing ± 12 dB of gain at a centre frequency of 3 kHz.

LO MID

Peaking section, providing ± 12 dB of gain at a centre frequency of 300Hz.

LF

Shelving section, providing ± 12 dB of gain at 50 Hz.

EQ IN

The EQ switch inserts the entire equaliser into the circuit. When switched out, the equaliser is totally bypassed.

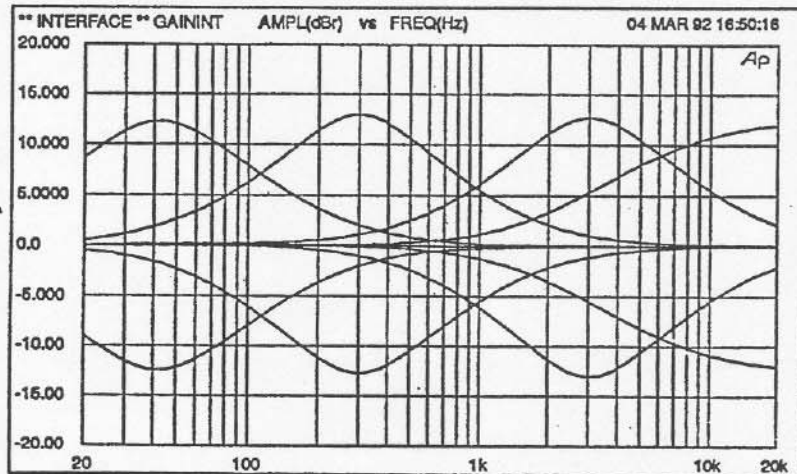

Auxiliaries

The INTERFACE console has six auxiliary buses, accessible on the Input module via 4 controls. The AUX controls send a mono signal which is derived from the stereo signal by summing the left and right channel signal.

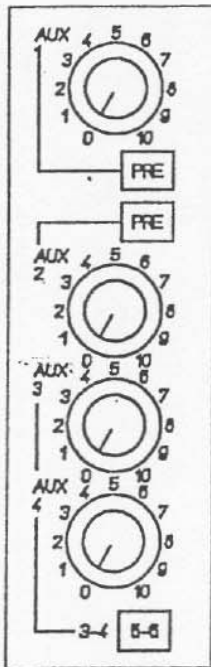

AUX 1

Controls the level of the channel signal fed to the AUX 1 bus. This signal is normally post-fader, unless the PRE button just below the AUX 1 control is depressed.

PRE

Feed the AUX 1 and AUX 2 controls with a signal taken pre-fader instead of post-fader. In this case, the signal on the AUX 1 & 2 buses is unaffected by the position of the channel fader.

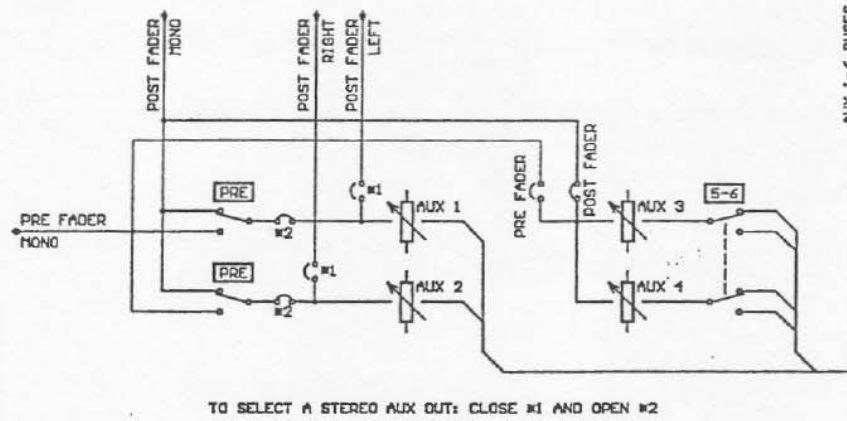

AUX 2

Controls the level of the channel signal fed to the AUX 2 bus. This signal is normally post-fader, unless the PRE button just above the AUX 2 control is pressed.

Note: Internal links allow the AUX 1 control to send the left channel signal and AUX 2 the right channel. This gives a stereo AUX output. The signal is post-fader, and the PRE switches then have no function.

AUX 3

Controls the level of the channel signal fed to the AUX 3 bus, and can be linked internally to be pre or post-fader. When the 5-6 switch is depressed, this control feeds the AUX 5 bus instead of the AUX 3 bus.

AUX 4

Controls the level of the channel signal fed to the AUX 4 bus, and can be linked internally to be pre or post-fader. When the 5-6 switch is depressed, this control feeds the AUX 6 bus instead of the AUX 4 bus.

Note: PRE and 5-6 are local to the module, they do not affect signal flow on any other module than the one on which they are located.

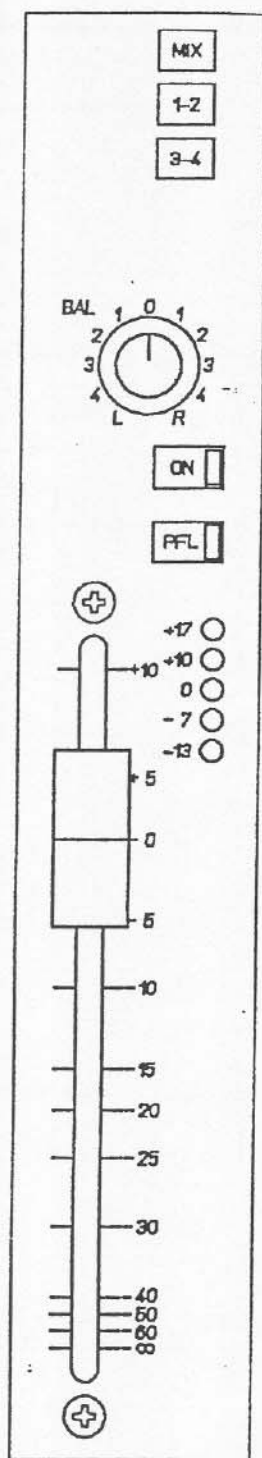

Routing

When any routing button is pressed, the BAL control is automatically inserted into circuit allowing the signal to be balanced in the stereo image.

BAL

When BAL is set to centre, equal levels are sent to both buses, with a 3 dB drop relative to fully clockwise or anti-clockwise. Setting the BAL control fully clockwise sends a level of 3 dB higher on the right bus and a level of 3 dB lower on the left bus.

MIX

Routes the post-fade, post-bal channel signal to the stereo mix bus.

1-2

Routes the post-fade, post-bal channel signal to output buses 1 and 2.

3-4

Routes the post-fade, post-bal channel signal to output buses 3 and 4.

Any unused channels should not be routed so as to maximise the performance of the console.

Channel Status

On

The ON switch enables the channel signal path, and is indicated by an LED in the switch when the channel is active. When OFF, all post-fade auxiliary sends and routing assignments are muted. It is recommended to switch all unused channels off to avoid additional noise on any parts of the mix.

PFL

The PFL button (or SOLO) feeds the post-EQ, pre-fader signal to the Monitor section (loudspeakers or headphones), replacing the master signal. The main stereo output of the console is not affected. The red LED in the PFL switch lights up when the PFL function is active. PFL signals from different sources that are active simultaneously are summed.

SIGNAL METER (LED)

A five segment LED signal meter shows when a signal is present above a threshold of -13 dBu, and will show peak signals up to +17 dBu. If the top LED is on partly or continuously, the signal is close to clipping, or severe distortion. The channel gain should be reduced. The meter displays the higher signal of the left or right channels.

STEREO FADER

The fader is the main signal level control for the channel, and is a long-throw type which gives smooth control of the channel level.

POSSIBLE JUMPER SETTINGS

On pcb 81 287

(*1) Factory pre-set

- J1-J6:** Determines which signal input from PHONO, CD, LINE (*1), DIGITAL or OPTICAL, is active at power-up.

- J7:** Determines the AUX 3/4 output: pre-fader or post-fader (*1)

- J8:** selects PFL or AFL
Pre-fader listening (*1) or after-fader listening

- J9/J10:** Changes the AUX 1/2 output from 2 x mono (*1) to 1 x stereo (AUX 1 = left, (J9), AUX 2 = right (J10))
Note! In stereo mode both PRE switches have no function!

2.4 6-IN-1 Mic Input Module 2816

The 6-In-1 Mic Input module allows up to 6 microphone inputs to be combined into a sub-mix, and then fed through a common equaliser, auxiliary sends and routing to the normal mix and group buses, and is just double the width of a normal input module. All mic inputs are on XLR connectors.

The module is ideal in situations where space is a premium, as for example 6 such modules would require only a 19" mixer to provide 36 mic inputs to the stereo mix.

The left side of the module contains the controls for the six mic inputs, while the right side contains the EQ, Aux sends, routing and fader. Input transformers may be fitted as an option. Phantom power is provided, and is switchable to all mic inputs simultaneously.

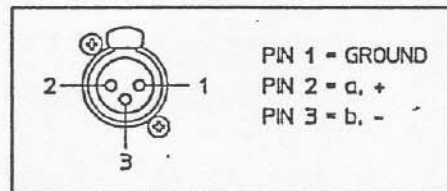
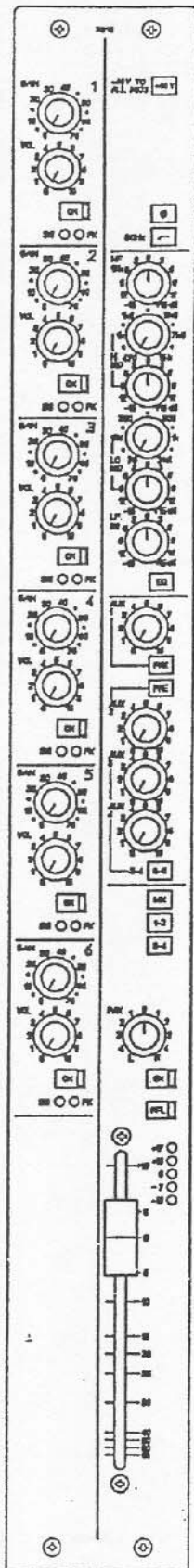

CONNECTOR PANEL

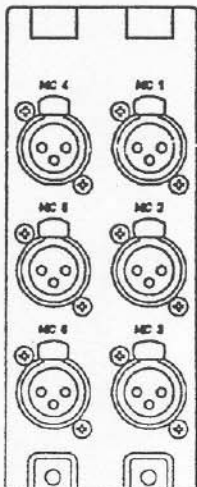

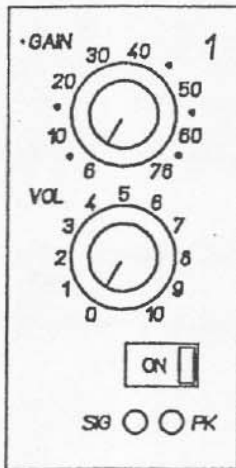

Mic Input Sub Mixer

The following describes one mic input section. All six are identical.

MIC 1 GAIN

The Mic input gain is adjustable from 6 to 76dB, on a rotary control.

MIC 1 VOLUME

The rotary volume control adjusts the amount of mic signal fed to the summing amplifier. You should be very careful in the combined use of the gain and volume controls in order to preserve the necessary headroom and noise performance of the console, with its normal operating position being at about 2 'o'clock on the scale.

MIC 1 ON

The On switch enables the microphone input to the channel. It is recommended that unused microphone inputs are switched off to minimise unwanted noise contribution.

SIG (LED)

This led illuminates when a signal is present at an input.

PK (LED)

This led illuminates when a signal is approximately 3dB below the clipping point, or severe distortion, measured before the volume control.

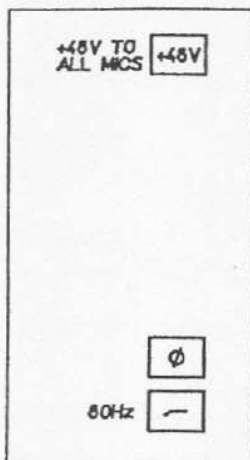

Main Signal Channel path

The summed signal from the six microphone inputs is fed to a normal mono input section for processing, prior to being routed to the mix and group buses. The controls on this section are almost identical to the normal mono input module 2802.

+48V

Switches phantom power to all mic inputs (6).

Phase Reverse

This switch reverses the phase of the summed signal. Note: It will therefore reverse the phase of all microphone inputs at once, there is no single mic phase reverse. If you find you have phase polarity problems between microphones on the same module, you will have to re-wire the cable from the microphone, or use a phase-reversal XLR adaptor.

High-Pass Filter

The high pass filter operates at a frequency of 80Hz.

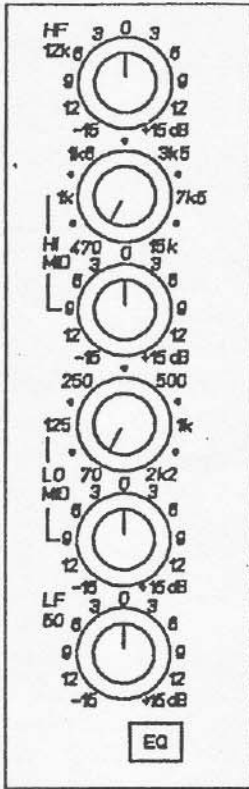

Equaliser

The equaliser is a four band section comprising two shelving sections and two sweepable peaking mid bands.

HF

Shelving section, providing ± 15 dB of gain at 12 kHz.

HI-MID

Peaking section, providing ± 15 dB of gain, with a centre frequency sweepable from 470 Hz to 15 kHz.

LO-MID

Peaking section, providing ± 15 dB of gain, with a centre frequency sweepable from 70 Hz to 2.2 kHz .

LF

Shelving section, providing ± 15 dB of gain at 50 Hz.

EQ In/Out

Switches the equaliser section in or out of circuit.

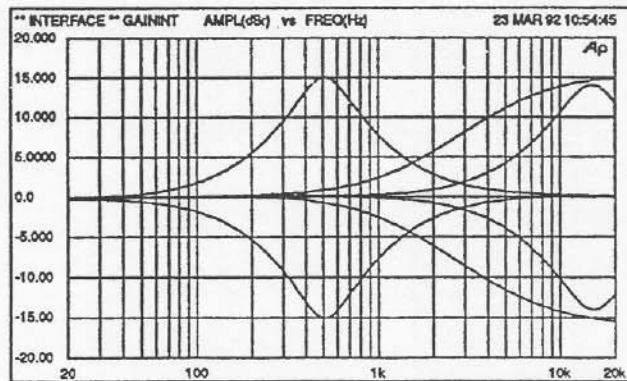
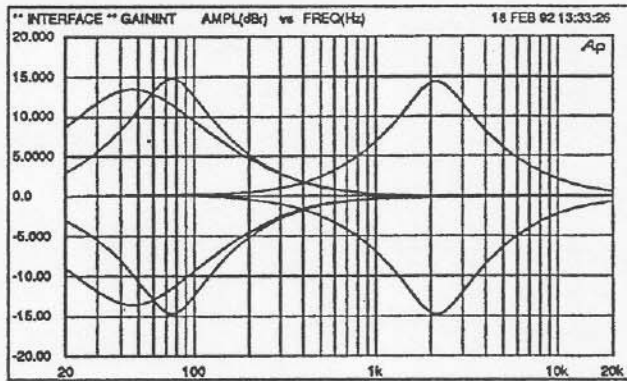

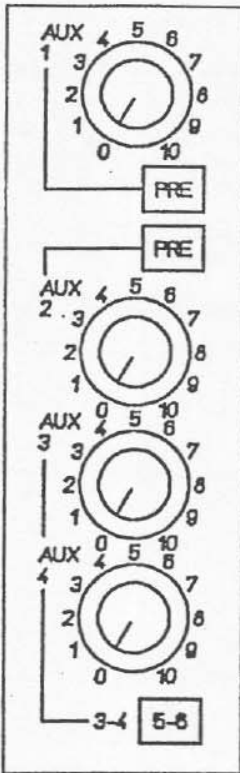

Auxillaries

The INTERFACE console has six Auxiliary buses, accessible on the input module via 4 controls.

AUX 1

Controls the level of the channel signal fed to the Aux 1 bus. This signal is normally post-fader, unless the PRE button just below the AUX 1 control is pressed.

PRE

Feeds the AUX 1 control with a signal taken pre-fader instead of post-fader. In this case, the signal fed to the Aux 1 bus is unaffected by the position of the channel fader.

AUX 2

Controls the level of the channel signal fed to the Aux 2 bus. This signal is normally post-fader, unless the PRE button just above the AUX 2 control is pressed.

PRE

Feeds the AUX 2 control with a signal taken pre-fader instead of post-fader. In this case, the signal fed to the Aux 2 bus is unaffected by the position of the channel fader.

AUX 3

Controls the level of the channel signal fed to the Aux 3 bus, and can be linked internally to be pre or post-fader. When the 5-6 switch is pressed, this control feeds the Aux 5 bus.

AUX 4

Controls the level of the channel signal fed to the Aux 4 bus, and can be linked internally to be pre or post-fader. When the 5-6 switch is pressed, this control feeds the Aux 6 bus.

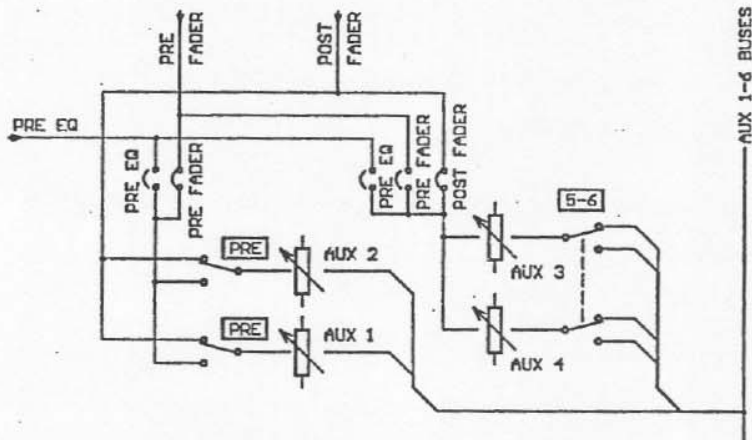

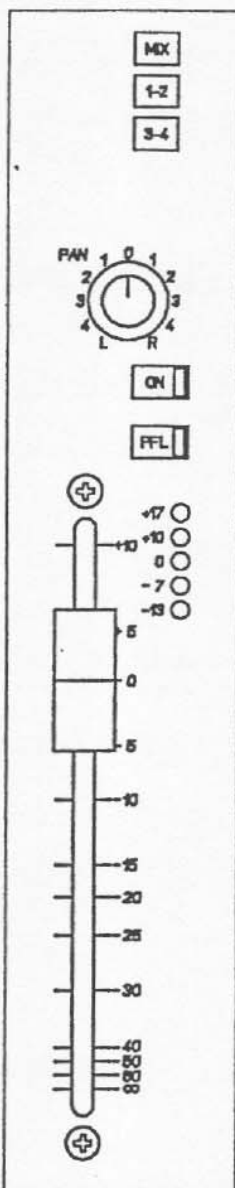

Routing

When any routing button is pressed, the PAN control is automatically inserted into circuit, allowing the signal to be positioned in the stereo image.

MIX

Routes the post-fade, post-pan signal to the stereo mix bus.

1-2

Routes the post-fade, post-pan signal to output buses 1 and 2.

3-4

Routes the post-fade, post-pan signal to output buses 3 and 4.

PAN

When PAN is set to its centre, equal levels are sent to both buses, with a 4.5dB drop relative to fully clockwise or anti-clockwise. Setting the PAN control fully clockwise sends a level of 4.5dB higher on the right bus and turns off the signal feed to the left bus, and vice-versa.

Channel Status

ON

The ON switch enables the channel signal path, and is indicated by an LED in the switch when the channel is active. When OFF, all post-fade auxiliary sends and routing assignments are muted. It is recommended to switch off all unused channels to avoid additional noise contribution.

PFL

The PFL button (or SOLO) feeds the post-EQ, pre-fader signal to the monitor section (loudspeakers or headphones), replacing the master signal. The main stereo output is not affected. The red LED in the PFL switch illuminates when the PFL function is active. PFL signals from different sources that are active simultaneously are summed.

SIGNAL METER (LED)

A five segment LED signal meter shows when a signal is present above a threshold of -13dBu, and will show peak signals of up to +17dBu. If the top led is on, partly or continuously, the signal is close to clipping, or severe distortion. The channel gain should be reduced.

FADER

The fader is the main signal level control for the channel, and is a long-throw type which gives smooth control of the channel level.



OPTIONAL LINK SETTINGS

ON P.C.B. 81 281

(*1) Factory preset

- J 1 :** Selects AUX1/2 Routing
 from PRE FADER (*1) or PRE EQ, when PRE-Switch is depressed

- J 2/3/4 :** Selects AUX 3/4 Routing
 from PRE EQ or POST FADER (*1) or PRE FADER

- J 5 :** Selects PFL or AFL
 from PRE FADER (*1) or AFTER FADER



2.5 Dual Line Input Module 2806

The Dual Line Input module comprises two identical line input sections on a single width module, each section having separate gain, Equaliser, and auxiliary send stages. As the two sections are identical, only one section is described below. The upper section on the module is labelled A, and the lower section B.

Inputs to the module are electronically balanced, and are provided on both XLR type and jack connectors.

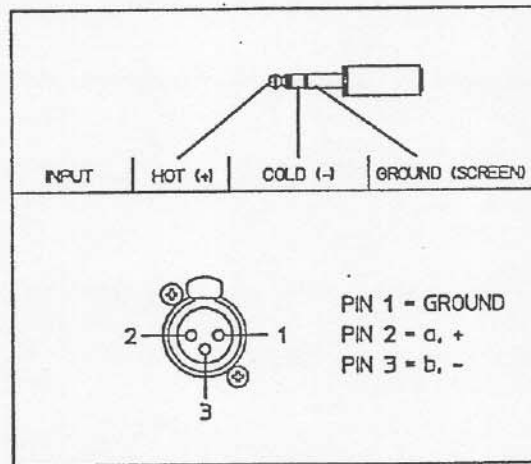

CONNECTOR PANEL



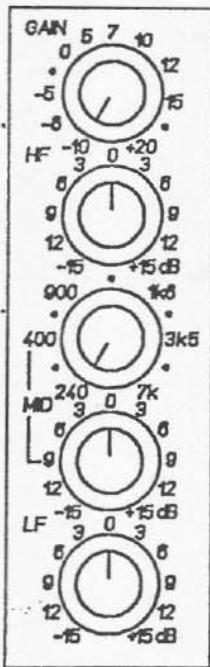

Gain

The input gain is adjusted by a rotary level control, with a range of -10 to +20dB.

Equaliser

The equaliser section on each input is a three band design, with two shelving sections and a peaking mid-band with variable centre frequency.

HF

Shelving, providing ± 15 dB of gain at 12kHz.

MID

Peaking, providing ± 15 dB of gain at a centre frequency variable from 240Hz to 7.0 kHz.

LF

Shelving, providing ± 15 dB of gain at 50Hz.

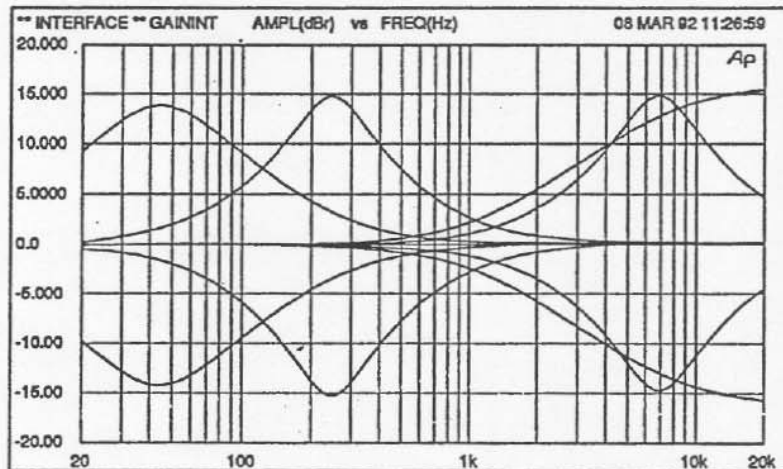

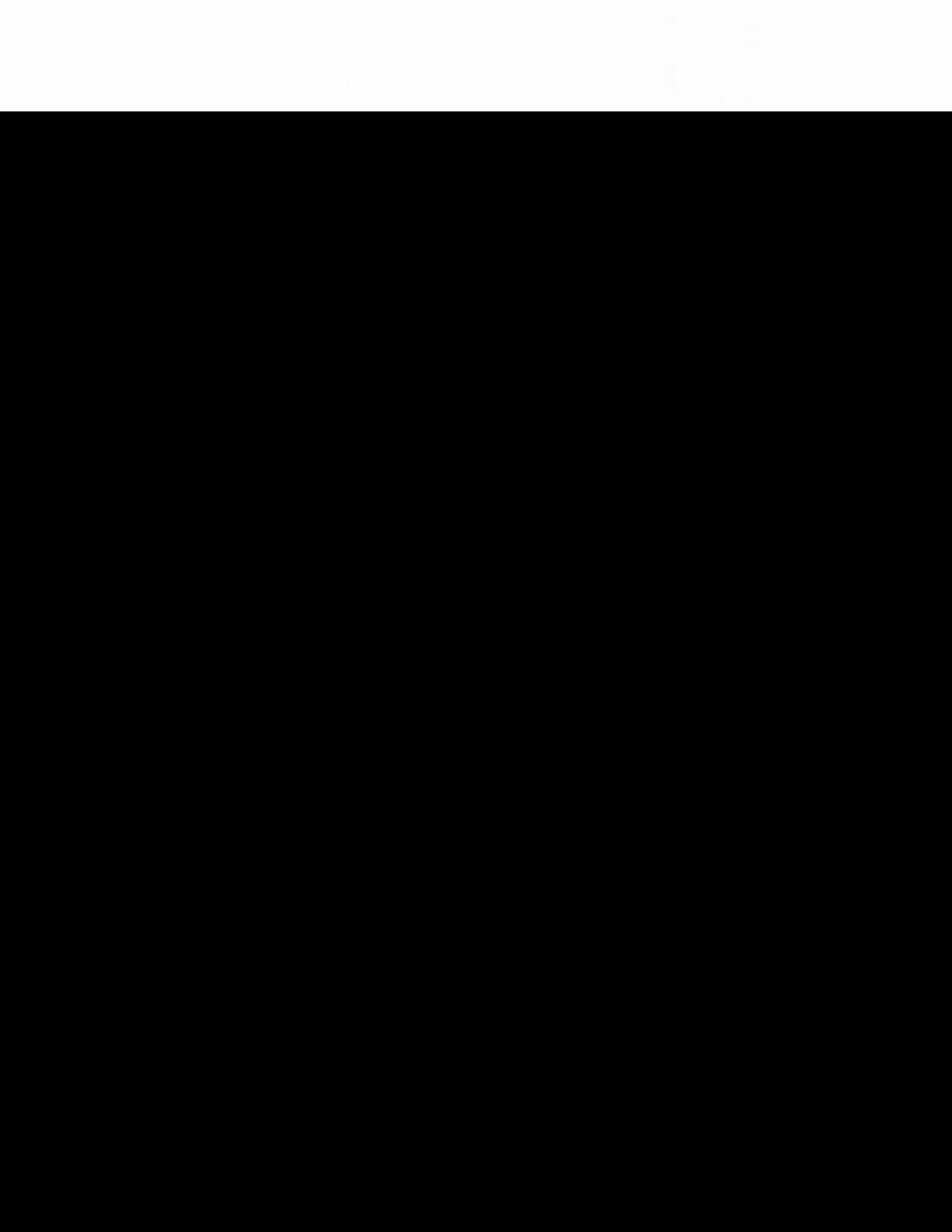

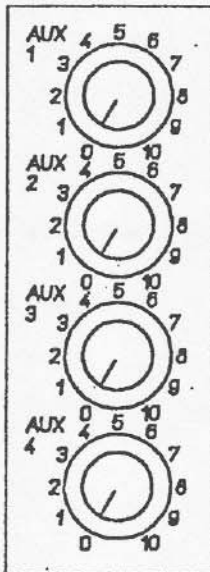

Auxiliaries

The auxiliary controls feed Aux buses 1 to 4 on the Interface console. There is no access to buses 5 and 6 from the front panel.

AUX 1

Controls the level of the channel signal fed to the Aux 1 bus. Internal links allow the signal feed to be taken pre or post the channel level control.

AUX 2

Controls the level of the channel signal fed to the Aux 2 bus. Internal links allow the signal feed to be taken pre or post the channel level control.

AUX 3

Controls the level of the channel signal fed to the Aux 3 bus, and is set post-fader.

AUX 4

Controls the level of the channel signal fed to the Aux 4 bus, and is set post-fader.

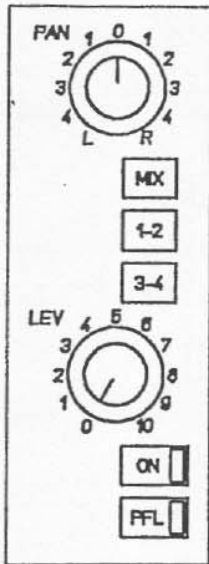

PAN

When PAN is set to its centre, equal levels are sent to both buses, with a 4.5dB drop relative to fully clockwise or anti-clockwise. Setting the PAN control fully clockwise sends a level of 4.5dB higher on the right bus and turns off the signal feed to the left bus, and vice-versa.

Routing

When any routing button is pressed, the PAN control is automatically inserted into circuit, allowing the signal to be positioned in the stereo image.

MIX

Routes the post-fade, post-pan signal to the stereo mix bus.

1-2

Routes the post-fade, post-pan signal to output buses 1 and 2.

3-4

Routes the post-fade, post-pan signal to output buses 3 and 4.

Level

This controls the overall level of the signal in the channel section, A or B.

Channel Status

ON

The ON switch enables the channel signal path, and is indicated by an LED in the switch when the channel is active. When OFF, all post-fade auxiliary sends and routing assignments are muted. It is recommended to switch off all unused channels to avoid additional noise contribution.

PFL

The PFL button (or SOLO) feeds the post-EQ, pre-fader signal to the monitor section (loudspeakers or headphones), replacing the master signal. The main stereo output is not affected. The red LED in the PFL switch illuminates when the PFL function is active. PFL signals from different sources that are active simultaneously are summed.

POSSIBLE LINK SETTINGS

On pcb 81 278

(*1) Factory pre-set

(xxx) Channel B

- J1(J11):** Selects PFL or AFL
from PRE-FADER (*1) or AFTER-FADER
- J2/3/4
(J12/13/14)** Selects AUX 1/2 Routing
from PRE-EQ or PRE FADER (*1) or POST-FADER
- J5/6/7
(J15/16/17)** Selects AUX 3/4 Routing
from PRE-EQ or PRE FADER or POST-FADER (*1)

2.6 Matrix Output Module 2844

The Matrix Output module is an alternative to the standard output module, and is more suited for sound reinforcement applications. When four such modules are fitted in an INTERFACE console, the output section provides the four Group outputs, a 4 x 4 matrix section, and four effects returns/external inputs. An insert send/return jack is provided so that external processing equipment may be inserted into the group output signal path. The effects return input is electronically balanced. Transformers may be fitted as an option to both Group and Matrix outputs.

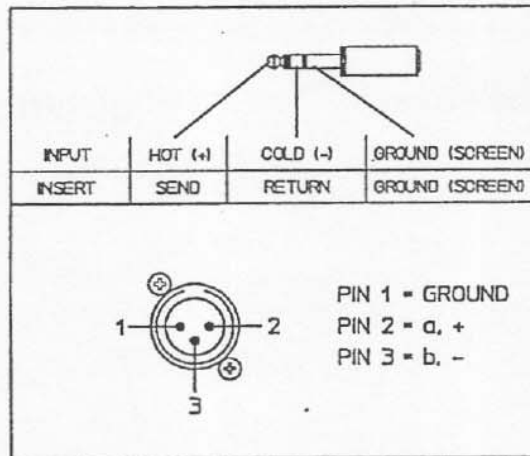
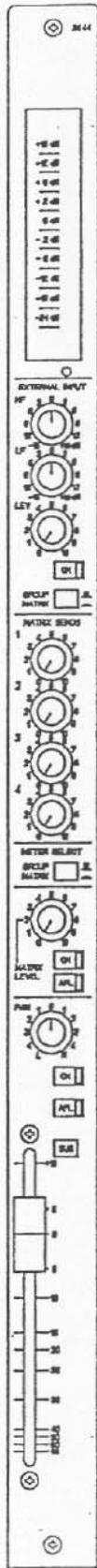

CONNECTOR PANEL



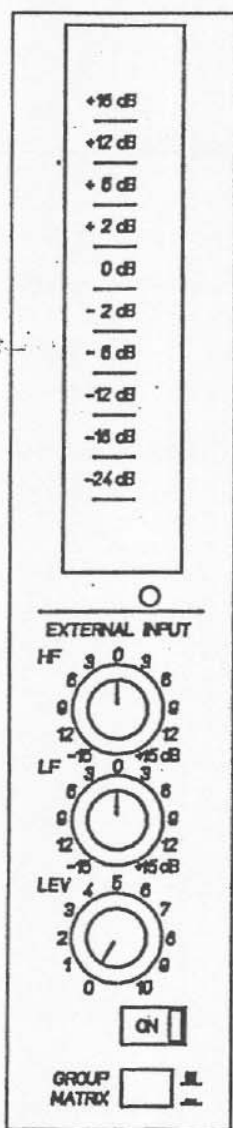

External Input

An external input provides a way of bringing in effects returns or other signals either to the group or matrix buses. The input is followed by a two-band equaliser and level control.

METER (LED)

The 20 segment led meter can be switched to display either the Group output level or the Matrix output level.

Equaliser

The two band equaliser features $\pm 15\text{dB}$ of gain at 8kHz (HF), and -60Hz (LF), with a shelving characteristic on each band.

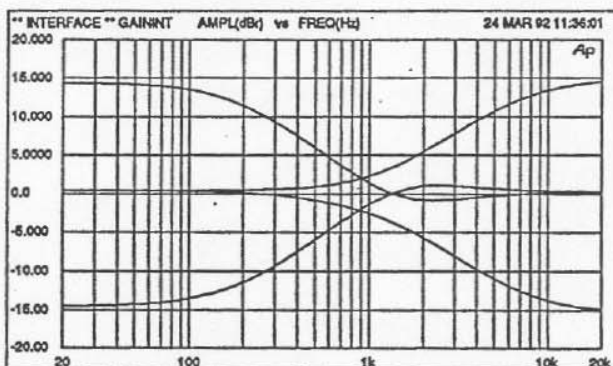

RET LEV

This is the level control for the return signal, and adjusts the amount of level sent to the Group bus or Matrix bus.

ON (Return)

This switch enables the effects return signal path. A green LED in the switch indicates when the return is 'On'.

GROUP/MATRIX (RETURN)

The external return input may be fed either to the Group bus on the module on which the return is connected, or to its Matrix bus. So on Group module 2, the return can be fed either to Group bus 2 or to Matrix bus 2.

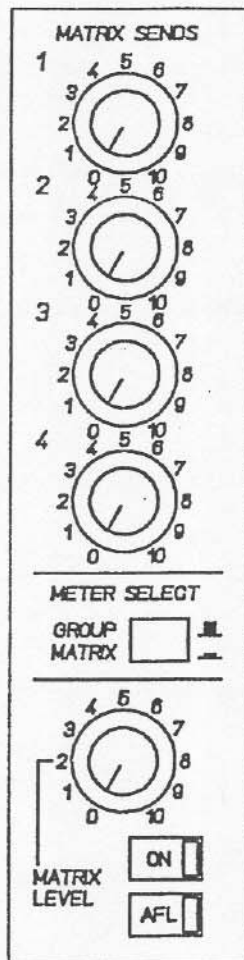
**Matrix 1 Send**

This rotary control adjusts the amount of the group signal from the module sent to matrix bus 1.

Matrix 2 Send

This rotary control adjusts the amount of the group signal from the module sent to matrix bus 2.

Matrix 3 Send

This rotary control adjusts the amount of the group signal from the module sent to matrix bus 3.

Matrix 4 Send

This rotary control adjusts the amount of the group signal from the module sent to matrix bus 4.

GROUP/MATRIX (METER)

The Group/Matrix switch determines which output the LED meter indicates. In the 'up' position, the meter reads the post-fader Group output, while in the 'down' position it reads the post-master level control matrix output.

Matrix 1 Master Level

This is the master output level control for the Matrix 1 bus. This would be found on the Group 1 module. Similarly, Matrix masters 2-4 would be on Group outputs 2-4.

ON (Matrix)

This switch enables the Matrix Output. A green LED in the switch indicates when the output is 'On'.

AFL (Matrix)

The AFL button (or SOLO) feeds the post-fader Matrix signal to the monitor section (loudspeakers or headphones), replacing the master signal.

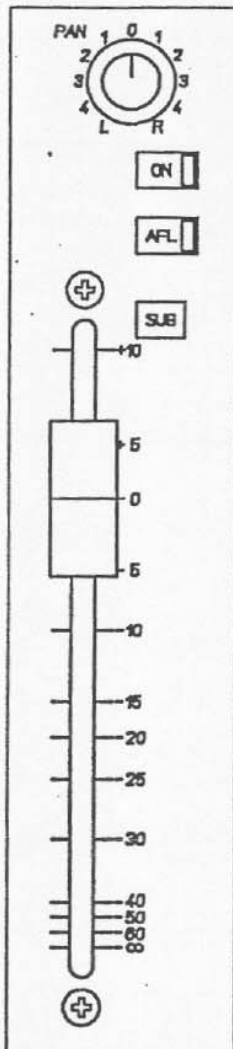

PAN

When PAN is set to its centre, equal levels are sent to both buses, with a 4.5dB drop relative to fully clockwise or anti-clockwise. Setting the PAN control fully clockwise sends a level of 4.5dB higher on the right bus and turns off the signal feed to the left bus, and vice-versa.

ON (Group)

This switch enables the Group Output. A green LED in the switch indicates when the output is 'On'.

AFL (Group)

The AFL button (or SOLO) feeds the post-fader Group signal to the monitor section (loudspeakers or headphones), replacing the master signal. The main outputs are not affected. The red LED in the AFL switch illuminates when the SOLO function is active. SOLO'ed signals from different sources that are active simultaneously are summed.

SUB

Pressing the SUB switch routes the Group output signal to the stereo mix via the PAN pot. The main group output is unaffected.

FADER

The long-throw fader adjusts the overall level of the Group output.

POSSIBLE LINK SETTINGS

On pcb 82 189

(*1) Factory pre-set

- J1/2/3/4 :** selects the Group Input
for example: link J2 means this module is assigned for group output 2
- J5:** remove for -10 dBV group output level
changes group output level from +4 dBu (*1) to -10 dBV.
- J6:** selects group output from an optional output transformer
- J8/9/10/11 :** selects the Matrix Input
for example: link J9 means this module is assigned for matrix output 2
- J 8 : Matrix 1
J 9 : Matrix 2
J 10 : Matrix 3
J 11 : Matrix 4
- J12:** remove for -10 dBV matrix output level
changes matrix output level from +4 dBu (*1) to -10 dBV.
- J13/14:** selects matrix output from an optional output transformer
- J15:** link for -10 dBV EXTERNAL INPUT level:
changes input level from +4 dBu (*1) to -10 dBV.
- J16:** selects the meter ballistics PEAK (*1) or Average
Attention: After changing the ballistics you may need for re-adjust
the offset trim (R88) for best display accuracy.

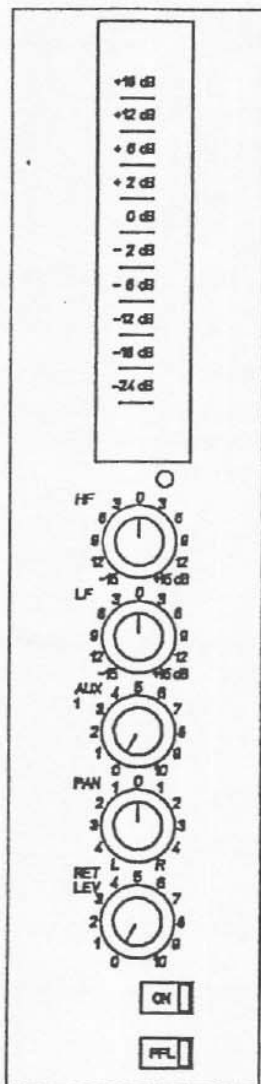

Led Metering

The twenty segment led meter reads the signal present on the Group output, or the pre-EQ signal present at the return input B. This latter signal may be the return signal, or the group signal, depending on the setting of the PA/Recording mode switch. The metering reads post-fader when reading group signals so will vary with fader position. In Tape mode, it will read the actual signal present before the level control of the return section (B). An internal link allows the meter to display with average (VU) or peak (PPM) characteristics.

Return Section A (to stereo mix)

Equaliser

The two band equaliser features $\pm 15\text{dB}$ of gain at 8kHz (HF), and 60Hz (LF), with a shelving characteristic on each band.

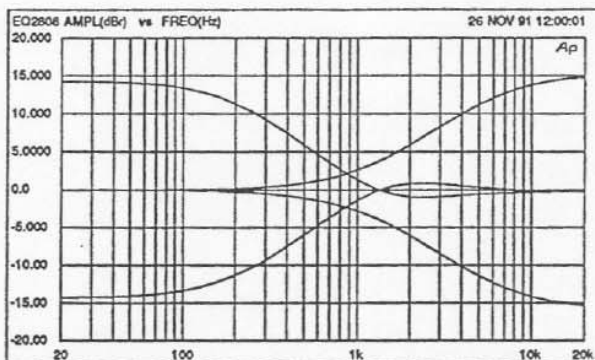

Aux 1

The return signal (A) can be fed to the Aux 1 bus via this level control, allowing the tape return signal to be fed to an external processing device or artist headphone monitoring system. The signal feed is taken pre- the level control, and is therefore unaffected by the position of the return level pot.

PAN

Positions the return signal within the stereo image, with a 4.5dB relative drop in the centre.

RET LEV

This is the level control for the return signal, and adjusts the amount of level sent to the stereo mix.

ON

The ON switch enables the Return A signal to the stereo mix bus, and has led indication when enabled.

SOLO (PFL)

The return signal may be solo'ed to the monitoring system. This solo signal is pre- the return level control. The led in the switch illuminates when solo is pushed.

Return Section B

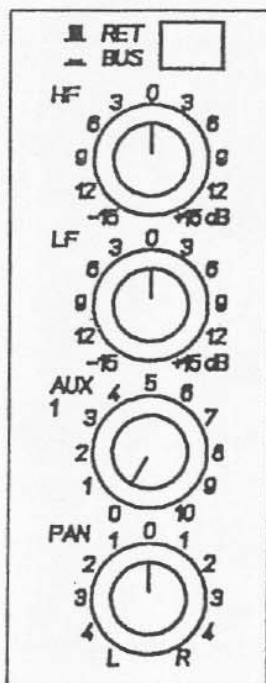

RET/BUS

This switch selects the input to the return section with its EQ. In the RET position, the input comes from the normal return input, is fed via the EQ, ON switch and PAN to the stereo mix. In the Bus position, the signal is taken from the group output, and fed as above to the stereo mix.

Selection of Bus sends the Return B input direct to its own group bus as an extender input to mix buses, and sends the group bus signal to mix with EQ, to use as an EQ'd sub-group to the mix with an auxiliary send.

If the console is being used for recording, this switch allows A/B monitoring of the tape send and track return signals. If the PA/Recording switch is set to Recording, the metering will follow the selection of RET or Bus on the input of the return section.

Equaliser

The two band equaliser features $\pm 15\text{dB}$ of gain at 8kHz (HF), and 60Hz (LF), with a shelving characteristic on each band.

Aux 1

The return signal (B) can be fed to the Aux 1 bus via this level control, allowing the tape return signal to be fed to an external processing device or artist headphone monitoring system. The signal feed is taken pre- the level control, and is therefore unaffected by the position of the return level pot.

PAN

Positions the return signal within the stereo image, with a 4.5dB relative drop in the centre.

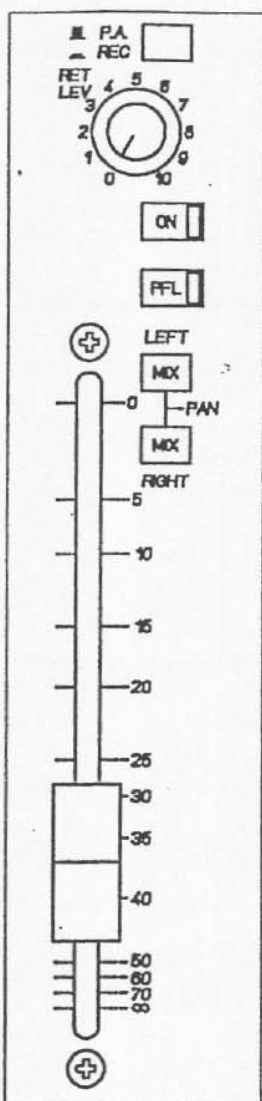

PA/Recording

This switch determines the way in which the return input is routed. In the PA mode, the metering will always read the group signal. If the Ret/Bus switch is also set to Bus at this time, the return input will take the group signal, and the external return signal will be routed to the same group bus. This is useful for adding in sub-mixers; for example, a stereo feed of a mix of keyboards from another small console, which all then go off to the group output.

If the switch is set to Recording, the signals follow the Ret/Bus switch selection, and no signals are routed from the return input back to the group buses. (block diagrams of signal flow see page 2.7-5)

RET LEV

This is the level control for the return signal, and adjusts the amount of level sent to the stereo mix.

SOLO (PFL)

The return signal may be solo'ed to the monitoring system. This solo signal is pre- the return level control. The led in the switch illuminates when solo is pushed.

ON

The ON switch enables the Return B signal to the stereo mix bus, and has led indication when enabled.

MIX-LEFT

This will route the group output signal to the left channel of the stereo mix bus.

MIX-RIGHT

This will route the group output signal to the right channel of the stereo mix bus.

If both MIX-LEFT and MIX-RIGHT are pressed, the signal will be fed via the Return B PAN pot to both left and right stereo buses. Note that in this case, Return B can not be used.

Fader

The long throw fader controls the level of the group output. When the MIX buttons are pressed, or BUS is selected, the fader will also control the level of the signal sent to the stereo mix. If the group output is to drive 'domestic' type equipment such as a tape machine which requires a lower input level, internal links change the nominal output level from +4dBu to -10dBV.

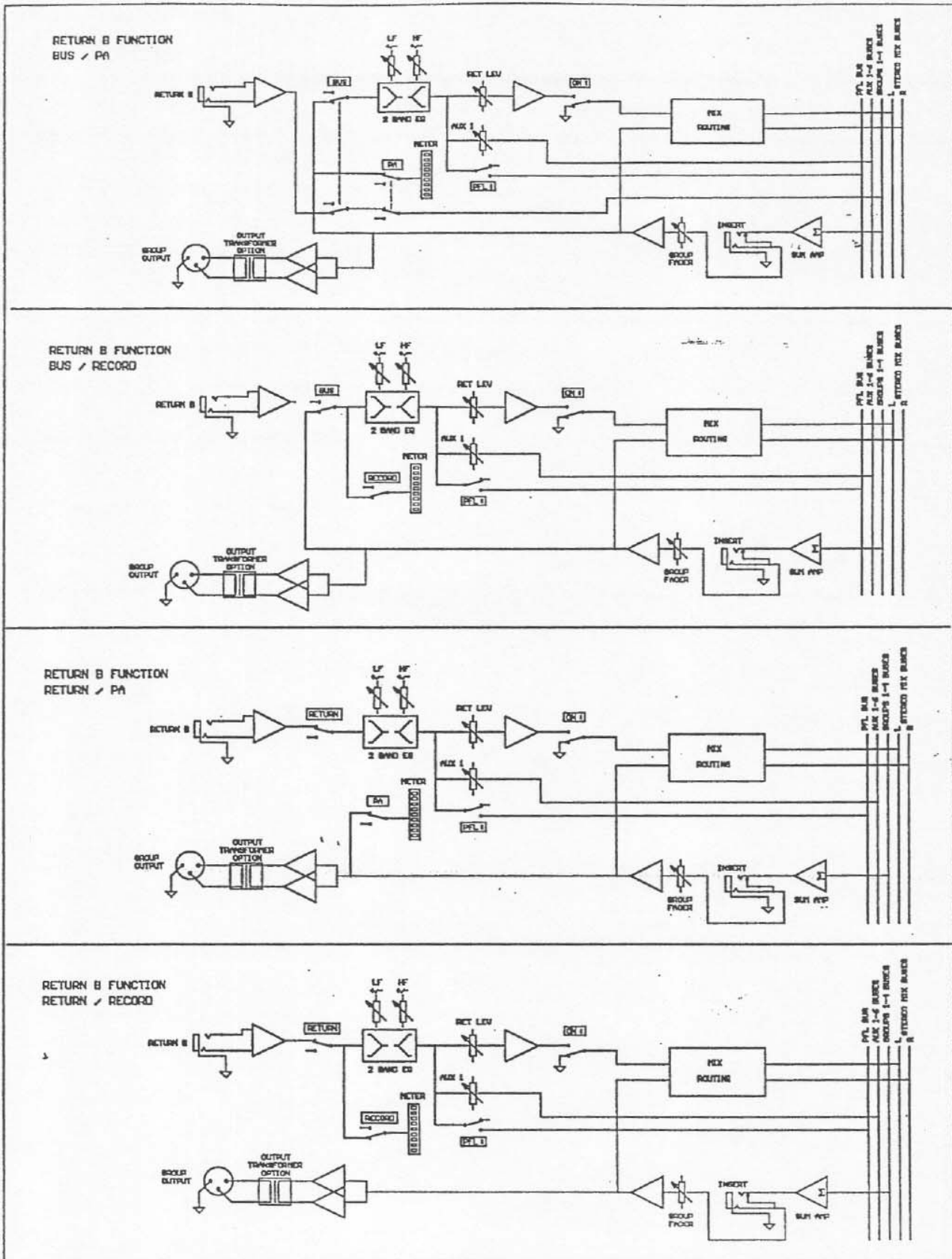

OPTIONAL LINK SETTINGS

ON P.C.B. 81 284

(*1) Factory preset

J 1/2/3/4 : selects the Group Input
for example: link J2 means this module is assigned for group output 2

J 5/6/7/8 : future option

J 11/12/13/14 : assigns the RETURN B signal to the group bus;
this selection should correspond to the selection of the links J1/2/3/4

J 15/16/17/18 : future option

J 20 : selects the meter ballistics Peak (*1) or Average
Attention: After changing the ballistics you may need to re-adjust the offset trim (R68) for best display accuracy

J 21/22 : selects output from an optional output transformer

J 23 : selects grounding for the output stage: chassis earth (*1) or main ground

J 24 : remove for -10 dBV group output level
changes group output level from +4 dBu to -10 dBV.

J 25/26 : link for -10 dBV TAPE RETURN (A and B) input level:
changes TAPE RETURN (A and B) input level from +4 dBu to -10 dBV.

2.8 MASTER MODULE

The Stereo Master module is always fitted to the INTERFACE console, and must always be mounted at the far right of the chassis. It contains the main stereo outputs, the Auxiliary master outputs, the monitoring section, and talkback microphone input. In addition, a BNC connector is provided for a gooseneck light if the console is to be operated under low or poor light conditions (maximum power 12 Volts, 5 watts).

The main stereo outputs have delayed-turn-on circuitry to prevent potential damage caused to speakers by turn-on 'thumps' generated by amplifiers. The stereo outputs are electronically balanced, and may also be transformer balanced as a cost option.

Insert points are provided in the stereo output signal path to allow the connection of processing equipment such as a stereo compressor/limiter. Connectors for these inserts are on the rear panel of the Master Module, and plugging in the Jack automatically breaks the normal signal path and inserts the external equipment.

The Stereo Mix, Group, and Auxiliary outputs have a nominal operating level of +4dBu. As some equipment operates at a nominal level of -10dBV, the stereo mix outputs and group outputs are provided with the facility to interface at these levels. All these main outputs may be fitted with transformers, to cater for situations where unknown earthing set-ups may cause problems (option).

The main outputs above will deliver full level of +21dBu unbalanced or +26dBu balanced into a 600 ohm load. Secondary outputs such as the channel insert sends and direct outputs (unbalanced) have a nominal operating level of -2dBu. They can only deliver the maximum output level of +21dBu into load impedances greater than 5 kOhms.

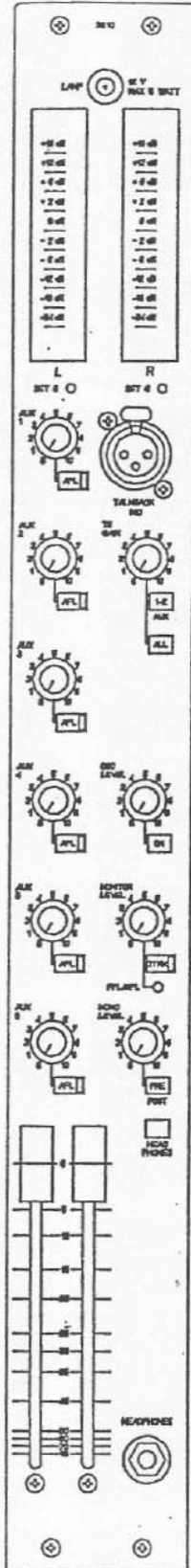

CONNECTOR PANEL

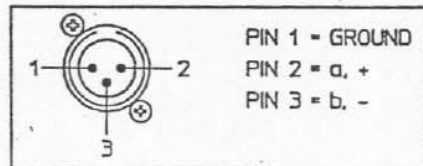
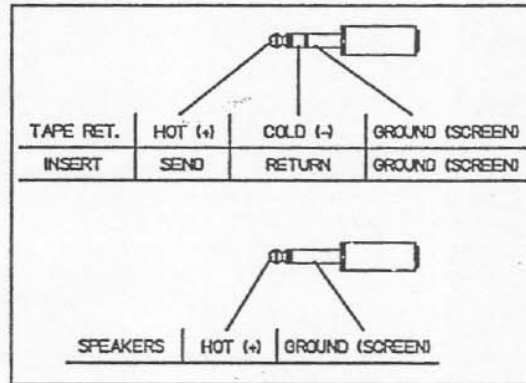
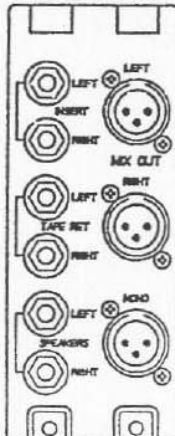

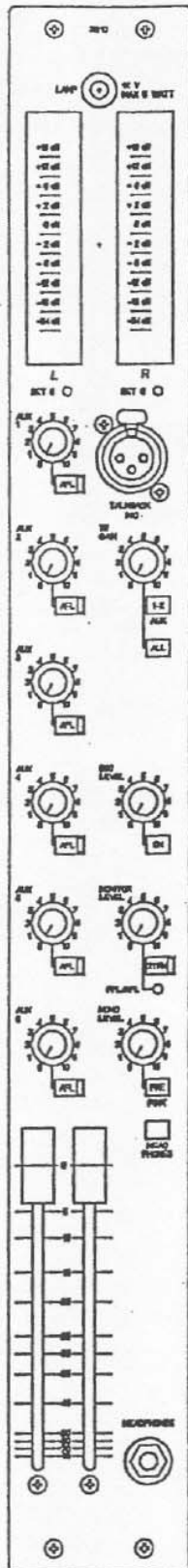

LED Metering

The two led bargraph meters follow under normal operating conditions the output of the stereo mix. If any SOLO (PFL or AFL) button is pressed, they show the level of the solo'ed signal, in mono.

SET 0

These sub-panel presets are used to calibrate the led meters for 0dB signal. They should not be touched under normal conditions, and should only be calibrated by an authorised technician.

AUX 1

This adjusts the master output level of the Auxiliary 1 bus. You will find that normally the best noise and headroom performance will be with the master level control set at approximately 7 on its scale (this is unity gain).

AFL 1

Pressing the associated AFL button will send the auxiliary 1 signal, at whatever level the master is set, to the main monitoring system, overriding the stereo signal on the monitors, and meters. The main stereo output is not affected.

Aux 2-6/AFL 2-6

The five other Auxiliary master level controls and associated AFL buttons operate in the same way as the Aux 1 controls described above.

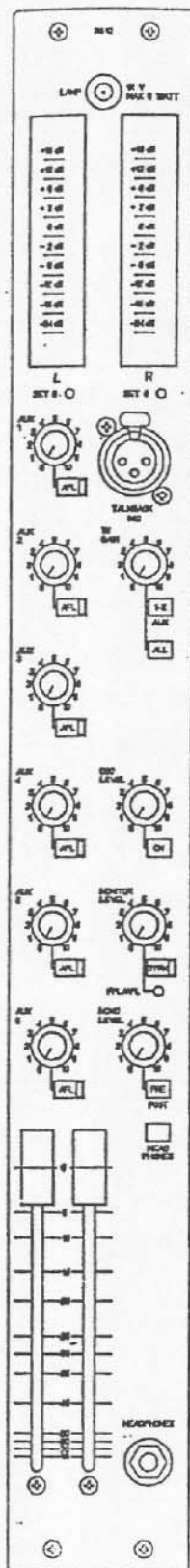

TALKBACK MIC

A microphone may be plugged in to this socket to provide talkback facilities to the output buses for artists or tape. The microphone may be a Dynamic type, or using an internal link for phantom powering, may be a condenser microphone.

TB GAIN

This adjusts the level of the talkback microphone signal.

1-2 / AUX

If 1-2 is pressed, the talkback microphone signal is sent to the Auxiliary 1 and 2 buses. If these buses are being used as artists headphone feeds, this switch allows the engineer to talk directly to the artist via the headphones. To avoid feedback, the control room output level is muted completely.

ALL

If the ALL button is pressed, the talkback microphone signal is sent to all the main outputs, including all auxiliary buses, group outputs and the stereo mix, for use in 'global' announcements. The control room monitor outputs are muted completely when ALL is pressed.

OSC LEVEL

This pot controls the level of the internal tone oscillator, which may be used for signal path testing or equipment alignment. The oscillator operates at a frequency of 1kHz.

ON

Switches on the oscillator for use as above, and routes the oscillator signal to all the buses: stereo mix, auxiliary outputs and group outputs. If either of the Talkback assign switches are pressed, the oscillator signal is overridden.

MONITOR LEVEL

This controls the level of the control room monitoring system. The signal feed to the monitoring system is selected from the stereo mix output, an external stereo input (for example, a master stereo tape machine), or any signal on the mixer which is SOLO'ed. The output (control room) will feed an external power amplifier and speakers. Alternatively, stereo headphones may be used via the headphone jack on the front panel of the master module.

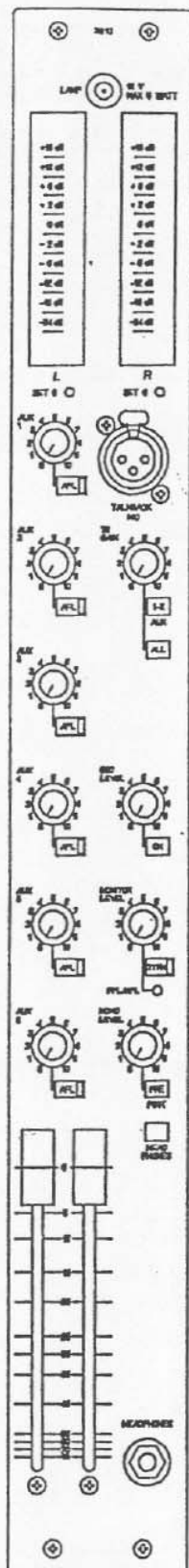

MIX/2 TRK

This switch selects the input to the monitoring system, from the stereo mix output or the external stereo input (2 Track).

Selection of any SOLO/AFL signal will override the MIX/2 Track selection.

PFL/AFL

If any SOLO or AFL button is pressed, this led will light to show that a signal has been solo'ed. If you have no output from the monitors when you expect one, this led will show if you accidentally have a SOLO button pressed on an input with no signal present.

MONO LEVEL

There is a separate mono output available which is a sum of the stereo mix output, and can be taken as a pre-or post-master fader feed, with its own level control. This is useful for a centre cluster PA feed, or a mono broadcast feed.

PRE

When the switch is up, the mono sum is taken after the main stereo faders. When depressed, the signal is taken pre-fader, so is unaffected by the master fader positions.

HEADPHONES (SWITCH)

The monitoring signal can be fed to the control room monitor outputs or the headphones.

FADERS

Independent left and right main faders are provided, allowing smooth control and balancing of the stereo output signal. They should normally be set in the top 10dB of the scale to ensure that you have enough headroom. If the stereo output is feeding 'domestic' type equipment which needs a lower input level, internal links are provided to reduce the drive level without reducing the fader gain and positions.

HEADPHONES

Stereo headphones with Impedances from 100 ohms to 600 ohms may be plugged into the headphone socket.

OPTIONAL LINK SETTINGS

ON P.C.B. 82 185 (Master left)

(*1) Factory preset

J 1/21/41/61 : Remove jumpers for AUX output level -10 dBV
81/101 changes the AUX output level from + 4 dBu to - 10 dBV

J 2 : selects the meter ballistics Peak (*1) or Average

Attention: After changing the ballistics you may need to re-adjust the offset trim (R126) for best display accuracy

ON P.C.B. 82 186 (Master right)

J 1/2/9 : Remove jumpers for MIX output level -10 dBV
changes the MIX output level from + 4 dBu to - 10 dBV

J 3/4/6/7 : selects output from optional output transformers
10/11

J 5/8/12 : selects grounding for the output stages:
chassis earth (*1) or main ground

J 13/14 : link for -10 dBV TAPE RETURN (left and right) input level:
changes TAPE RETURN (left and right) input level from + 4 dBu to - 10 dBV.

J 15 : selects Phantom Power ON/OFF (*1) for the TALKBACK MIC

J 16 : selects the meter ballistics Peak (*1) or Average

Attention: After changing the ballistics you may need to re-adjust the offset trim (R238) for best display accuracy

J 17 : links main ground and chassis earth (unlinked *1)

ON P.C.B. 86 193 (rear AUX sockets)

J 12/13/22/23/32/33/

42/43/52/53/62/63 : selects outputs from optional output transformers

J 11/21/31/41/51/61 :

disconnects the sockets from chassis earth.

3. MODULE BLOCK DIAGRAMS

3.1 INPUT MODULE 2802

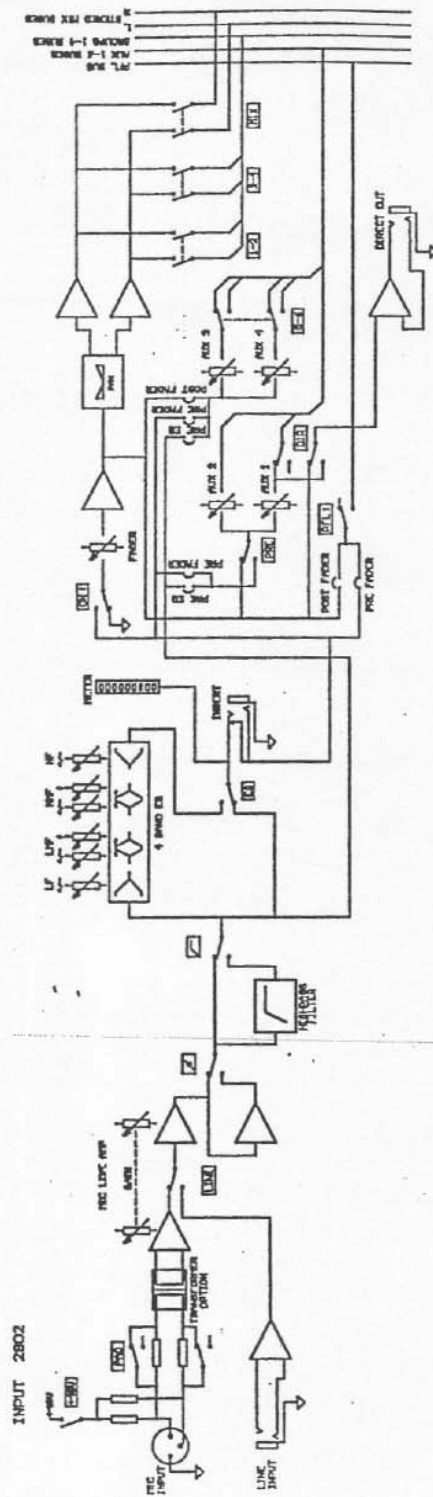

3.2 STEREO INPUT MODULE 2804

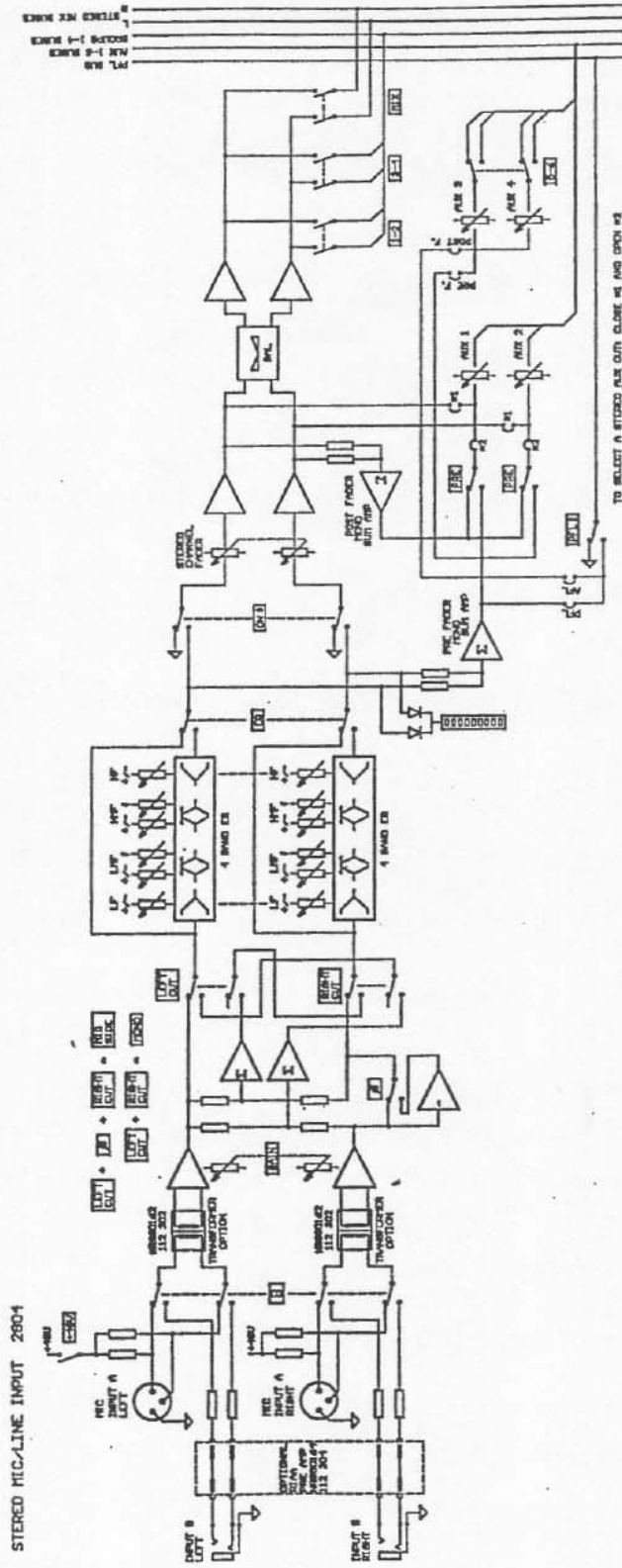

3.3 DIGITAL INPUT MODULE 2824

DIGITAL STEREO INPUT 2824

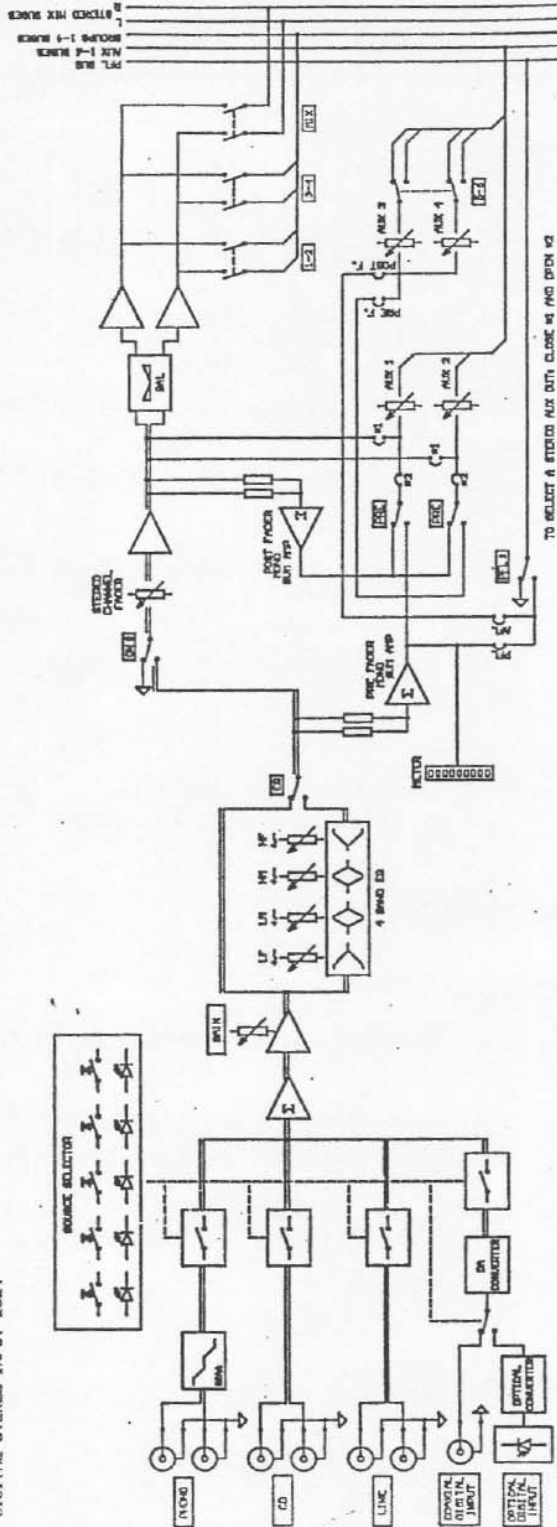

3.4 6-IN-1 MIC INPUT MODULE 2816

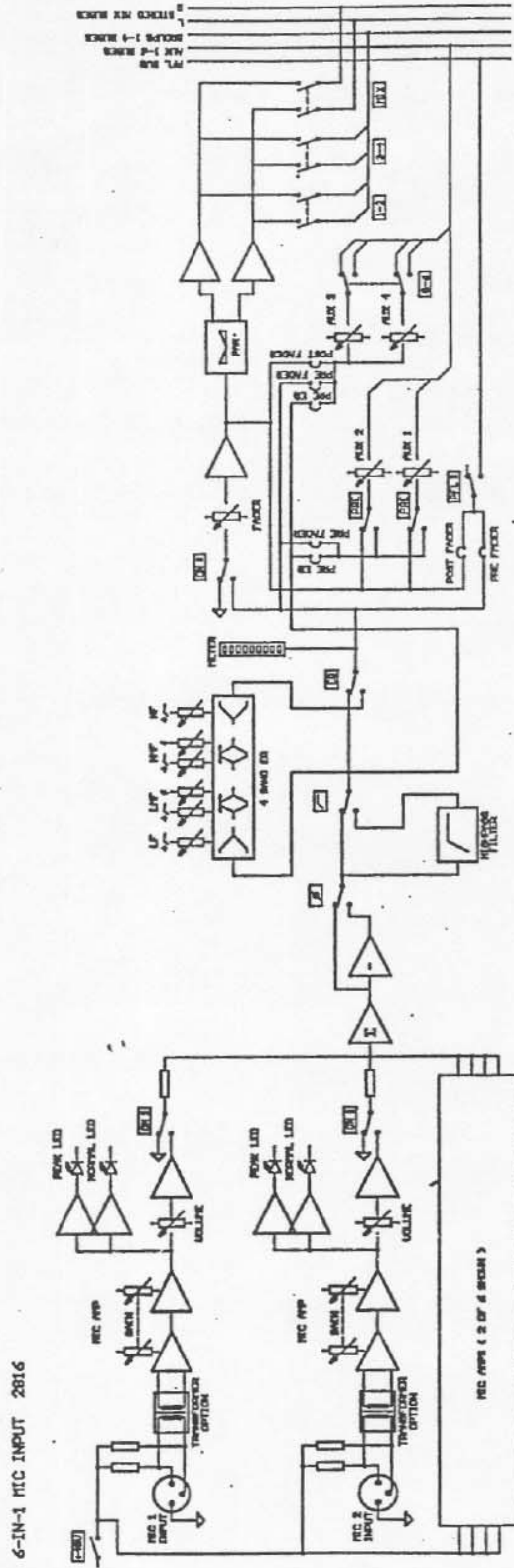

3.5 DUAL LINE INPUT MODULE 2806

PFL BUS
 AUX 1-4 BUSES
 GROUPS 1-4 BUSES
 STEREO MIX BUSES

DUAL LINE INPUT 2806 & ONE INPUT SHOWN

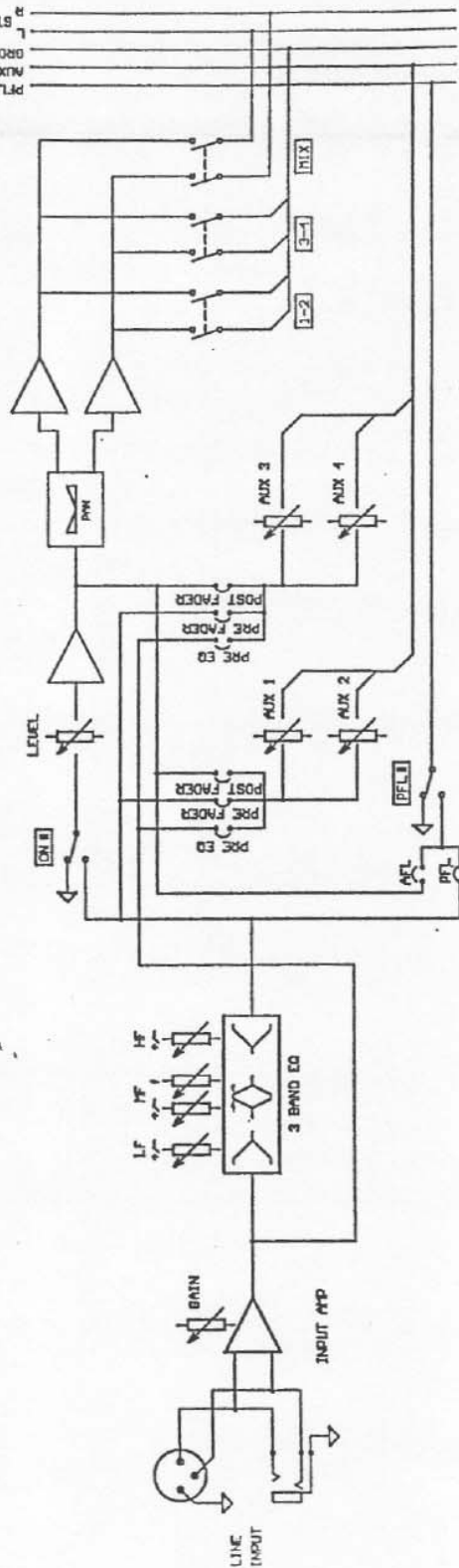

3.6 MATRIX OUTPUT MODULE 2844

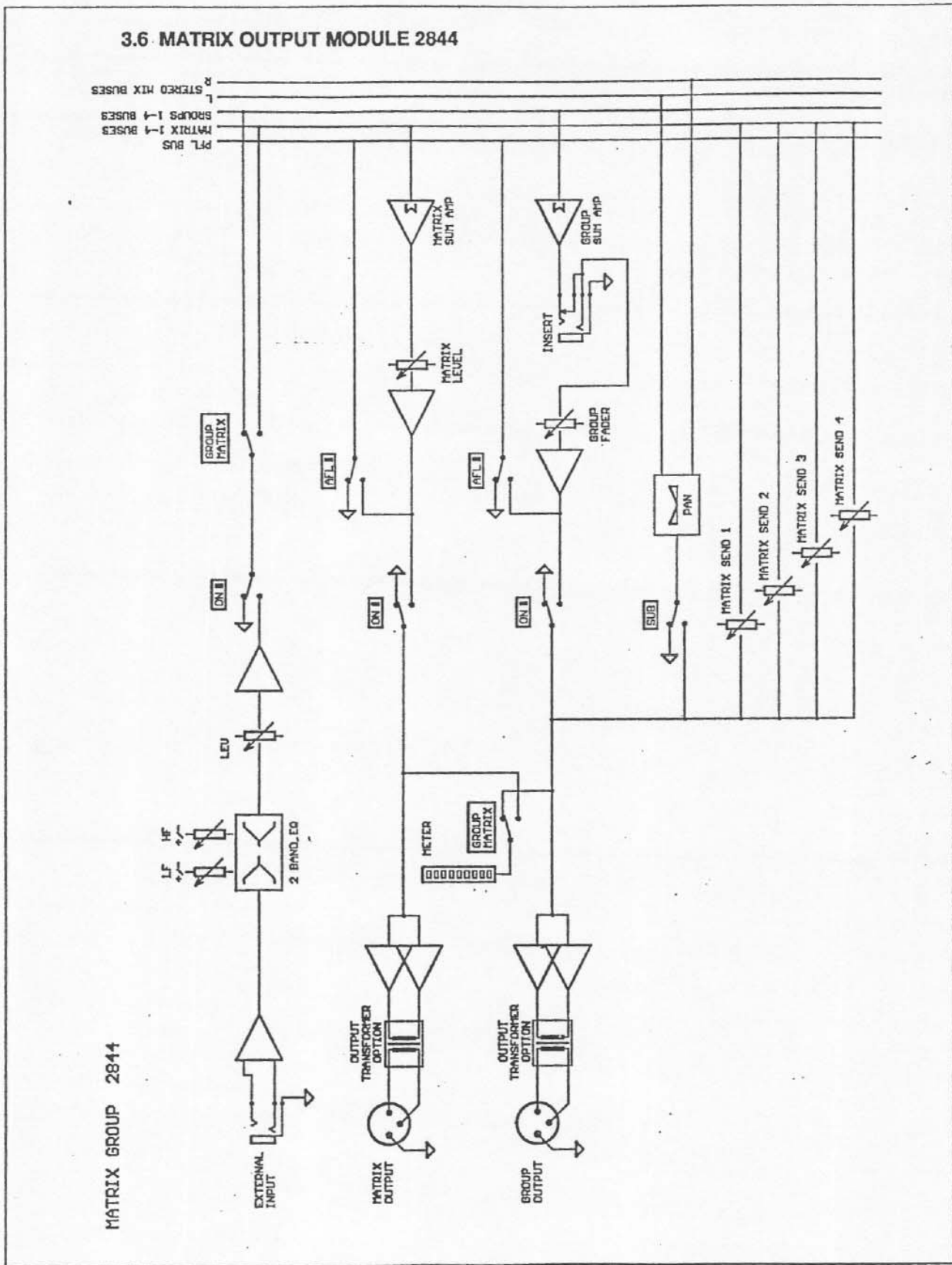

MATRIX GROUP 2844

3.7 GROUP OUTPUT MODULE 2808

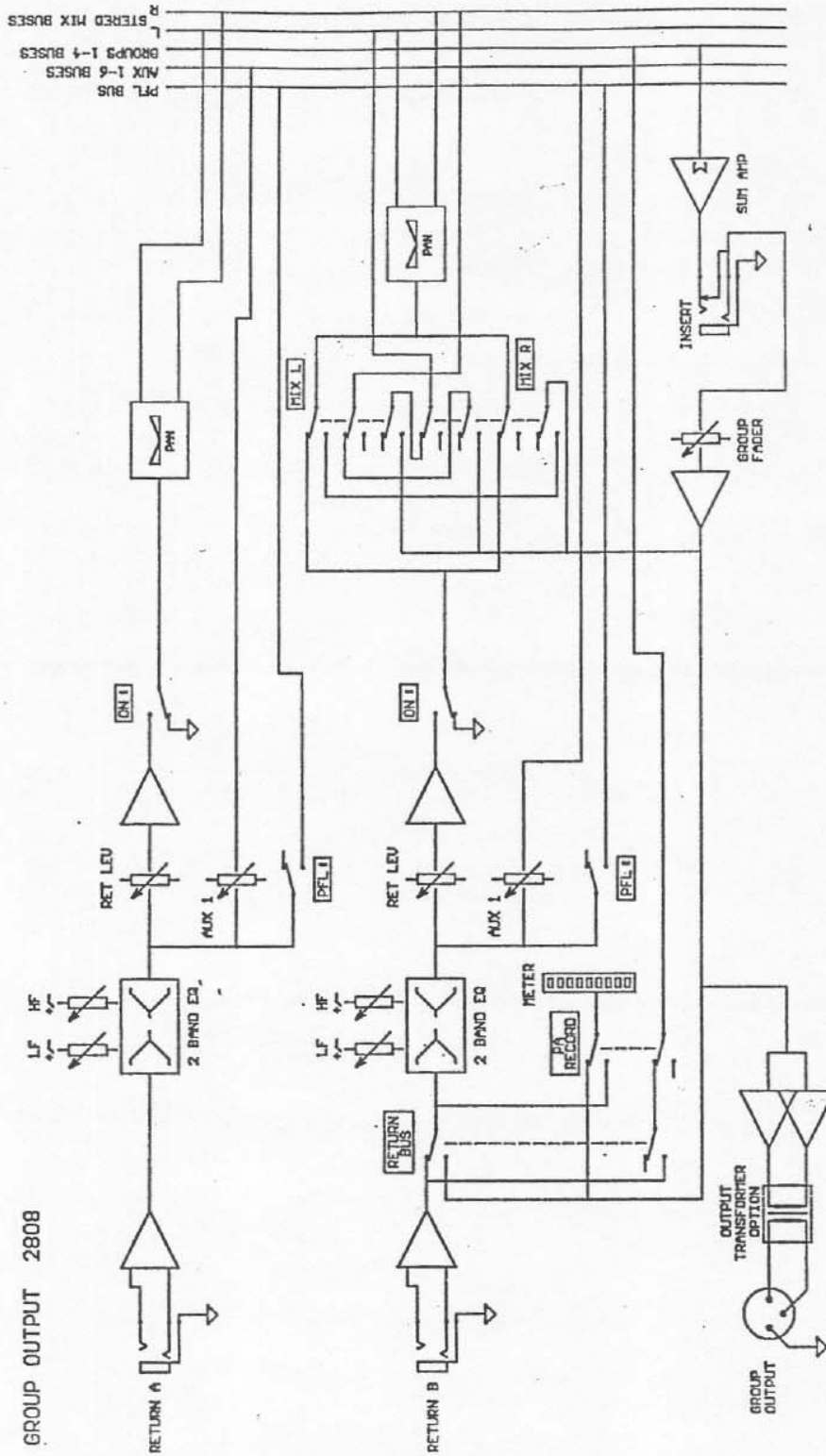

3.8 MASTER OUTPUT MODULE 2810

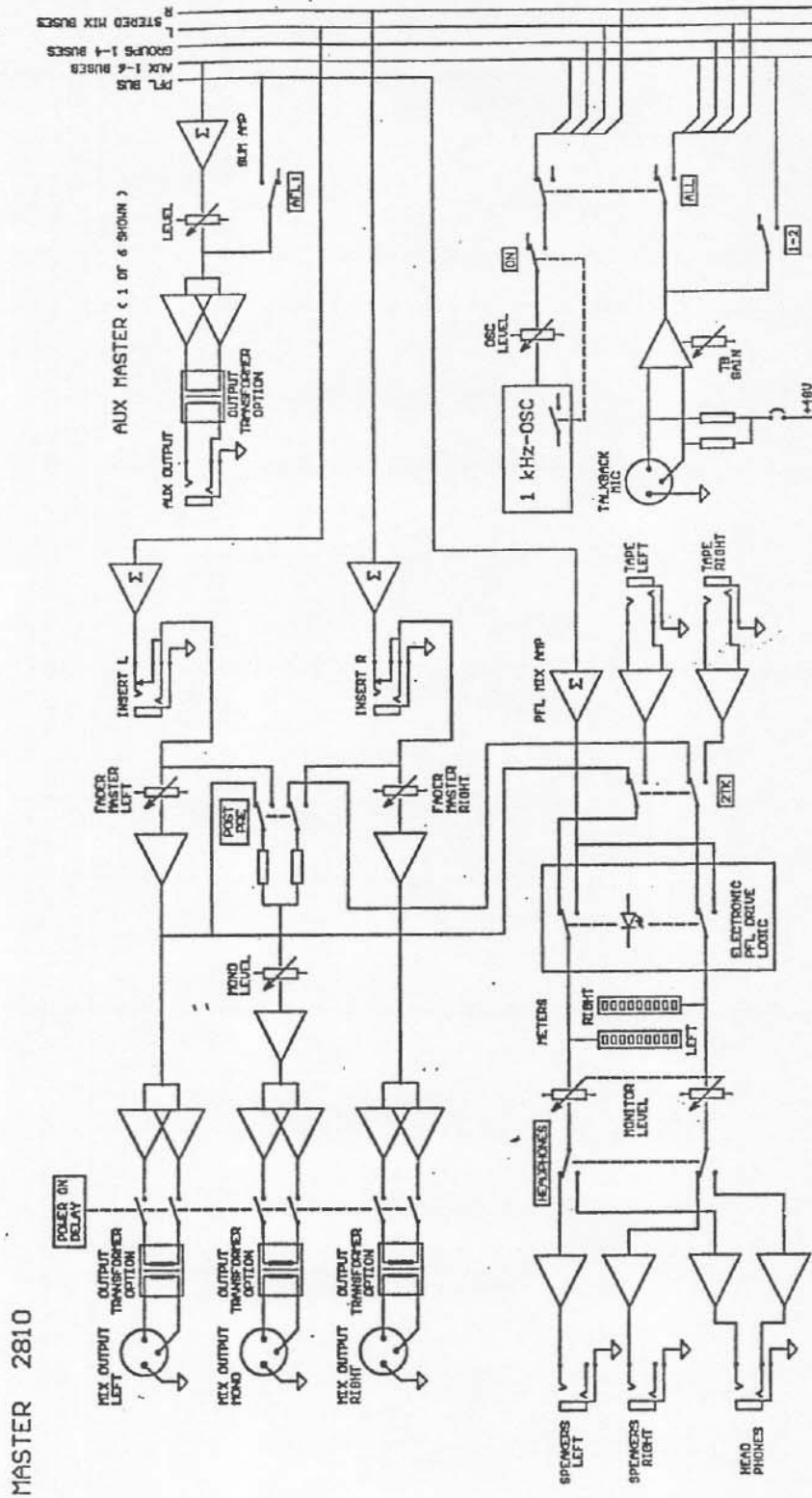

MASTER 2810

4. POWER SUPPLY REQUIREMENTS AND SETTINGS

IMPORTANT:

PLEASE READ THIS SECTION CAREFULLY BEFORE CONNECTING YOUR POWER SUPPLY TO THE AC MAINS FOR THE FIRST TIME.

The available power supply for the INTERFACE mixer is named PSI 2835.

4.1 Description

The INTERFACE power supply is a conventional linear unit which produce DC voltages by rectifying, smoothing and regulating AC voltages from the secondary windings of the mains transformer. INTERFACE mixing consoles employ a number of DC voltage supply levels in their operations and these are all provided at the output of the supply unit.

The unit dissipates a certain small amount of heat which should not be considered abnormal.

The unit is designed for installation in 19" racks, but may be operated free-standing as well. Please refer to the section 'Recommendations for installation' (4.4).

Indicators are provided on the front panel to show correct operation of the power supply.

In addition, the power supply unit is provided with a delayed turn-on circuit, which operates a relay on the INTERFACE Master Module, preventing the output of the console being operated before the power supply is at its correct operating voltages. This helps to prevent any transients reaching amplifiers and giving turn-on 'thumps'.

4.2 Mains Voltage Selection

SPECIAL ATTENTION SHOULD BE PAID TO THE FOLLOWING:

These units are capable of operating over a wide range of AC mains supply voltages by means of a comprehensive set of user-selectable settings. It is important to ensure that the correct voltage setting has been selected for the level of local mains voltage supply for safe, uninterrupted operation of the units.

There are four MAINS VOLTAGE SELECTION switches inside the top of the unit, which are accessible by removing the blanking plugs covering them. DO NOT DISCARD THE BLANKING PLUGS as you may need them if the console is used on tour. Voltage selection is achieved by moving the switches into the correct positions using a screwdriver blade, as shown by the symbols at the side of the access holes. In this way the unit is set up for operation at one of the following mains supply ranges:

NOMINAL VOLTAGE	OPERATING VOLTAGE RANGE
V AC	V AC
240	216 - 264
230	207 - 253
220	198 - 242
120	108 - 132
100	90 - 110
90	81 - 99

On the '90' setting the working input voltage range can be reduced to under 100 V. This enables the unit to function down to only 81 V AC on the mains supply. This facility has been incorporated to overcome the problems that some power supplies have with internal regulation when operating from a poorly regulated mains supply.

In any situation where the nominal mains level is 100 V AC but poor mains regulation is suspected, the RMS level should be measured using an AC Voltmeter. If the observed voltage is at 90 V or below, then the '90' position should be selected before connecting the unit to the mains supply.

DO NOT CHANGE THE VOLTAGE SETTING WITHOUT FIRST UNPLUGGING THE MAINS LEAD and REPLACE ALL THREE BLANKING PLUGS after correct voltage selection has been made.

4.3 Replacing the mains fuse.

In the event of incorrect position of the mains voltage selectors, a mains power surge or underrated fuse value, the mains fuse on the front panel may blow and the power supply unit will not function. Switch the ON/OFF switch back to the OFF position. Check the fuse and replace if necessary. Also, check that the voltage selection is correct for the mains supply level before switching the unit ON again.

TO AVOID RISK OF FIRE ONLY REPLACE WITH THE CORRECT VALUE FUSE AS INDICATED ON THE UNIT.

In the event of repeated failure of the mains fuse please consult your INTERFACE Dealer from where you purchased the unit.

THIS UNIT CONTAINS NO USER SERVICEABLE PARTS. REFER ALL SERVICING TO QUALIFIED SERVICE PERSONNEL OR YOUR INTERFACE DEALER.

4.4 Recommendations for Installation

The power supply is designed for 19" rack-mounting and will occupy 2 HU of rack space when the four feet are removed from the base of the unit. For free-standing operation the enclosed rubber feet may be fitted.

As with any other power supply that contains a large mains voltage transformer, it is preferable to provide a degree of physical isolation of the unit from other electronic equipment, particularly that which carries low level audio signals, to avoid any possible hum pick-up. For this reason, the unit is provided with a long (4 metres) cable to enable it to be positioned away from the mixing console.

For the same reason, when rack-mounting, it is preferable to avoid locating the unit adjacent to signal processing equipment. It should be noted that if a complete rack containing a PSI 2835 unit is to be operated from a different mains voltage, then the unit should be withdrawn from the rack in order to reselect the mains voltage setting at the same time as resetting any other equipment.

Due to the built-in fan there is no need of special cooling arrangements.

Finally, some consideration should be given to the earthing arrangement of the system. The console chassis is earthed through the mains earth, via the power supply. When rack-mounting, care should be taken to avoid any possible ground-loops in the system which would introduce audible hum to otherwise clean audio signals. Ground loops may occur where signal processing equipment patched to the console, has its signal earth commoned to the equipment chassis. The ground loop is formed if this chassis and the PSI 2835 chassis are in electrical contact (eg through common fixing rails they share in the rack).

This situation can easily be avoided with the built-in ground-lift switch on the back of the PSI 2835 unit.

Attention: Now the console chassis is not earthed to the mains earth!!

4.5 GENERAL

As with all electrical/electronic equipment, some care should be taken when handling this unit. Protect the unit from bumps. The unit must not be dropped. Avoid using or storing the unit in the following environments, as damage may result:

- * locations subject to extremes in temperature, such as under direct sunlight or near heating units.
- * near water and moisture and environments otherwise subject to high humidity.
- * dusty environments.
- * places with high levels of vibration.

TO AVOID RISK OF FIRE DO NOT EXPOSE THIS UNIT TO RAIN OR MOISTURE.

Retain all packaging for transportation in case the unit requires servicing. Put this manual, along with all the other relevant documents, in a safe place.

4.6 PSU SPECIFICATIONS

PSI 2835

Mains Input Voltage Range
AC +/-10% 50/60Hz

240/230/220/120/100/90V

Rated Power Consumption (max)

300W

Mains fuse rating
240/230/220 V
120/100/90 V

T3.15A (250V)
T6.3A (250V)

Outputs

	Max Current	Max Noise
DC Voltage +17 V	3.5A	-70dBu
-17V	3.5A	-70dBu
+48V	0.35A	-80dBu

Operating Temperature Range (ambient) -10 + 50 Deg C

Overall Dimensions:

Height	89mm (2HU)	3.5"
Width Chassis	424mm	16.8"
Front Panel	483mm	19.0"
Depth	260mm	10.23"
Net Weight	7.8kg	17lbs

4.7 Approval

The PSI 2835 is completely tested in accordance with IEC 65, 5th edition 1985 and amendment No. 1 and EMKO-TUE (12B-SEC) 205/91.



PIN Assignment XLR POWER SUPPLY



- PIN 1 = switched output relays
- PIN 2 = +17V
- PIN 3 = -17V
- PIN 4 = Screen
- PIN 5 = +48V
- PIN 6 = Ground/Screen

MAINS VOLTAGE SELECTION

WARNING
 SHOCK HAZARD. DO NOT OPEN. TO REDUCE THE RISK OF FIRE HAZARD AND ELECTRIC SHOCK DO NOT EXPOSE INSTRUMENT TO RAIN OR MOISTURE.
 AVIS
 RISQUÉ DE CHOC ELECTRIQUE. NE PAS OUVRIR.

NO USER SERVICEABLE PARTS INSIDE. REFER SERVICING TO QUALIFIED SERVICE PERSONNEL.

ENSURE CORRECT MAINS VOLTAGE SETTING AND CORRECT FUSE BEFORE CONNECTING MAINS SUPPLY. DO NOT SWITCH MAINS VOLTAGE SETTINGS WHILE MAINS SUPPLY IS CONNECTED.

MAINS VOLTAGE SELECTION

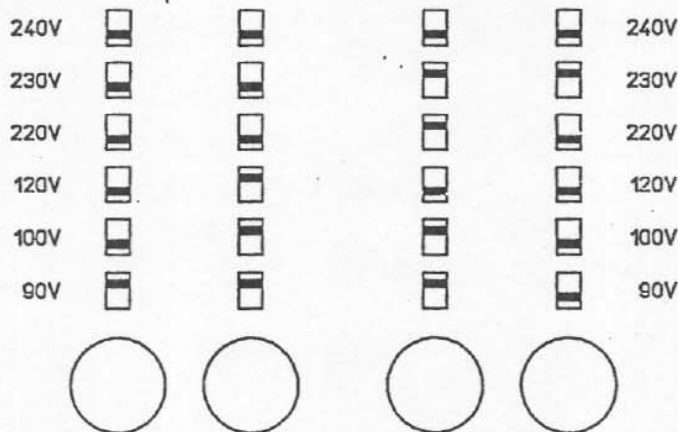

8 Input Frame

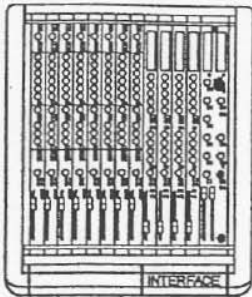

8-4-2

8 Input Rack Frame

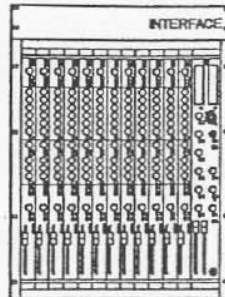

12-2 RACK

16 Input Frame

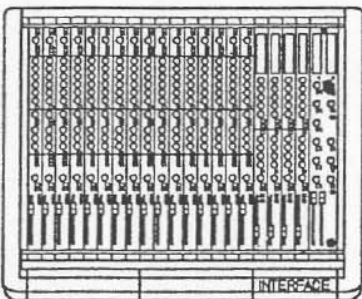

16-4-2

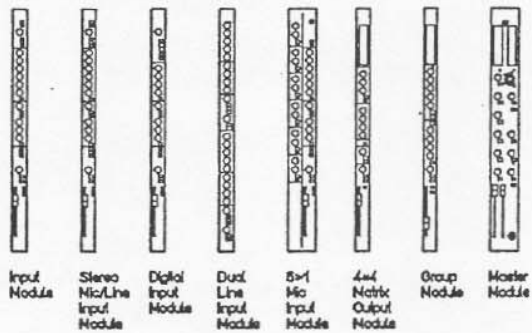

24 Input Frame

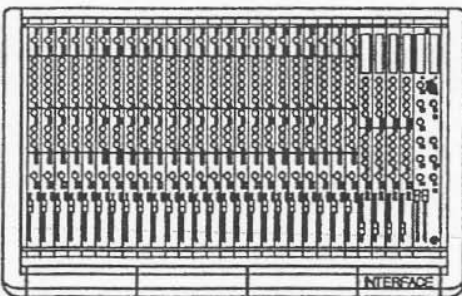

24-4-2

32 Input Frame

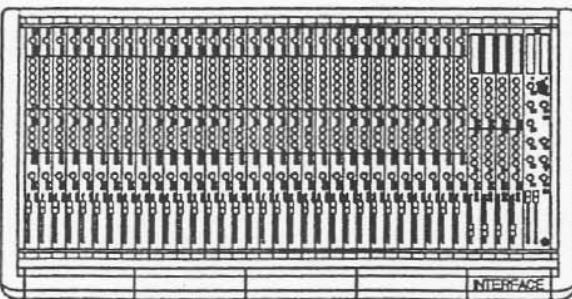

32-4-2

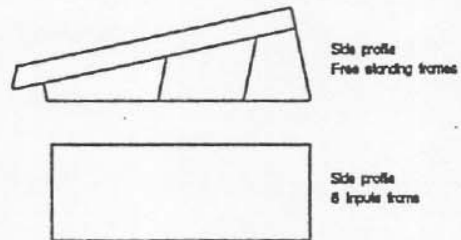

Shown are just samples of possible configurations.

All measurements shown in millimetres (inch)

FREE STANDING FRAMES

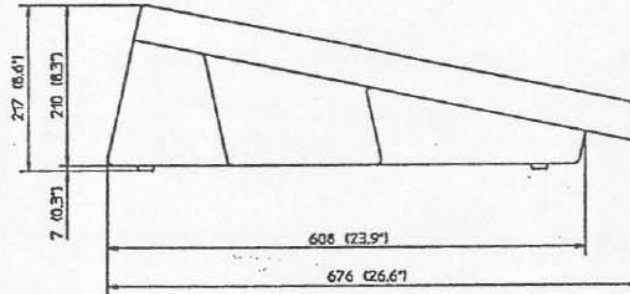

- 8 - 546 (21.57)
- 16 - 796 (31.47)
- 24 - 1046 (41.27)
- 32 - 1296 (51.07)
- 40 - 1546 (60.97)

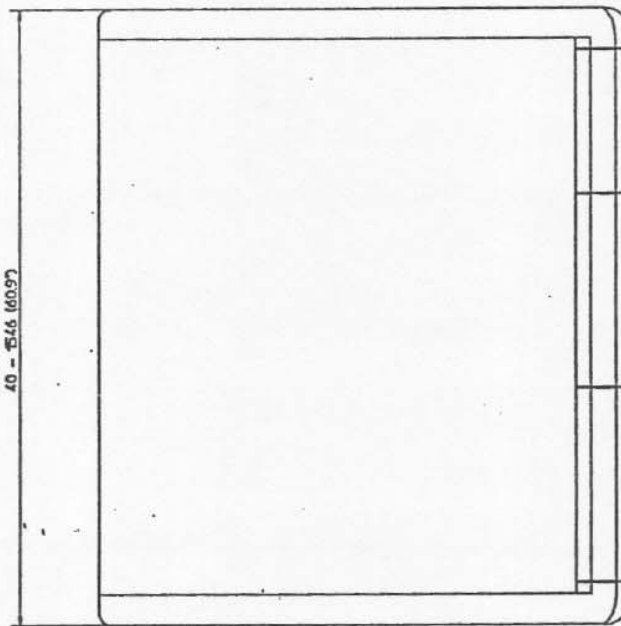

6. MODULES, FRAMES, AND OPTIONS**Modules**

2802 Input Module
2804 Stereo Line Input Module
2806 Dual Line Input Module
2824 Digital Input
2808 Group Module
2844 Matrix Output Module
2810 Master Module
2816 6-in-1 Mic Input Module
2899 Blank Module
PSI 2835 Power supply 3,5 A

Frames

8 Input frame
8 Input frame rack
16 Input frame
24 Input frame
32 Input frame

Options

Input transformer 90162 (one piece)
Output transformer 90163 (two pieces)
Output transformer 90166 (one piece)
RIAA Preamp 90164
Lamp L-418

Flightcase

FCI-8 Flightcase 8 Channel
FCI-16 Flightcase 16 Channel
FCI-24 Flightcase 24 Channel
FCI-32 Flightcase 32 Channel

7. EXAMPLES OF INTERFACE APPLICATIONS

7.1 Sound Reinforcement

The INTERFACE mixer is highly suited for small to medium Sound Reinforcement applications, including PA use for bands and concerts. In this situation, the Aux Sends would feed external processing devices, their outputs being fed into the Aux Returns (type A). The Direct Outputs may be used for single channels to feed, for example, a reverb unit for a single microphone, without using up an auxiliary bus. Stereo Effects Returns could be brought in on Stereo Input modules.

Additionally, Aux sends could be used to provide a monitor mix for the stage, their outputs feeding power amplifiers and stage wedges.

The Main stereo output would feed the house PA, or via amplifiers and perhaps crossovers, your own PA speakers.

The Control Room output allows the engineer to listen on headphones to solo'd channels or stage monitor mixes without disturbing the house output.

A second Interface Mixer could be used to sub-mix keyboards and other instruments, and feed into the main mixer via Aux Returns (type B) and using the PA/Bus switching mixed with the sub-groups. This keeps the number of input channels in use to a minimum.

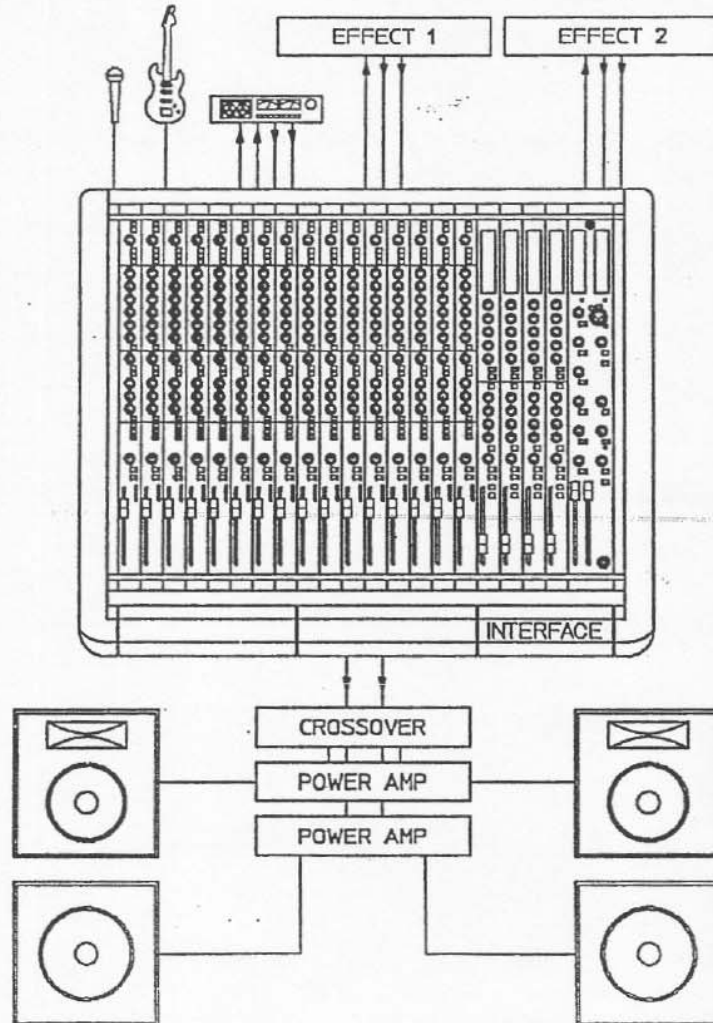

7.2 Recording

Recording on a four-track machine with INTERFACE is very easy, but there is scope to use larger machines with INTERFACE.

The four outputs of the INTERFACE console can be used to record on a machine with more than 4 tracks in two ways:

1. The outputs may be paralled to other tracks, and Safe/Ready selection used to determine which track is actually in Record.
2. The Channel Direct Outputs can be used to feed single microphones or instruments to individual tracks. In this way, a 24 input chassis could provide four sub-group feeds and, if required, 24 individual track sends.

The returns from the Tape machine will normally be fed to the Tape Returns on the Group Module, although extra tracks may be fed to normal input modules of course.

The main Stereo Output feeds the two-track mastering machine, while control room monitoring is fed from the Control Room Outputs.

The Auxes would be used as effects sends, and/or providing a headphone mix for artists (via a suitable amplifier).

