

# N/D<sup>®</sup> 357A, 357AS

## SPECIFICATIONS

<b>Frequency Response,</b>	
<b>Close Response:</b>	25 to 20,000 Hz
<b>Far Response:</b>	55 to 20,000 Hz
<b>Polar Pattern:</b>	supercardioid
<b>Open Circuit Voltage:</b>	2.2 mV/Pascal @ 1000 Hz
<b>Power Sensitivity:</b>	-53 dB (where 0 dB = 1 mW/10 dynes/cm <sup>2</sup> )
<b>Dynamic Range:</b>	141 dB
<b>Equivalent</b>	
<b>Output Noise:</b>	17 dB (0 dB = .0002 dyne/cm <sup>2</sup> )
<b>Impedance:</b>	150 ohms balanced (Lo-Z)
<b>Weight:</b>	7.05 ounces (200 grams)
<b>Dimensions,</b>	
<b>Height:</b>	7.12 inches (181 mm)
<b>Diameter:</b>	2.05 inches (52 mm)
<b>Shank:</b>	0.80 inch (20 mm)

## OPERATION

The low-frequency response of the N/D357A can be extended by positioning the microphone closer to the sound source as documented in the specification section. This proximity effect occurs when the microphone is placed within 12 inches of the sound source and increases as the working distance is reduced. The low-frequency response is tailored to provide bass boost without the "boominess" of many directional microphones. Thus, closer working distances can be used with N/D357A to reduce the risk of sound system feedback (ringing) while preserving intelligibility.

The N/D357AS is equipped with an on/off switch that shorts the mic element when set to off position permitting the user to have local muting control.

The dynamic element of the N/D357A will provide reliable operation in humidity and temperature extremes-adverse conditions that would render condenser microphones useless. For years of trouble-free operation "on-the-road," the N/D357A utilizes an all-metal-core construction, from the hardened windscreen to the Warm-Grip covered handle.

Patent numbers 4,745,020, 4,824,715, and 4,646,873.

## POLARS

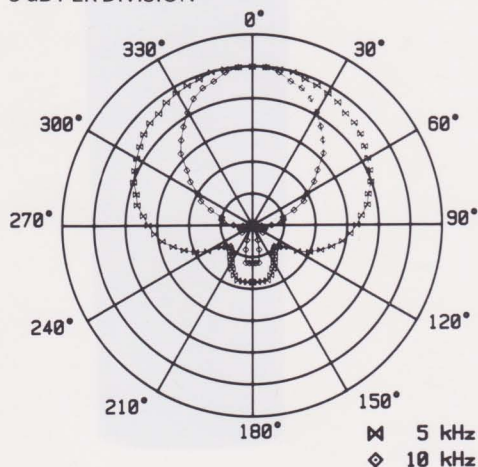
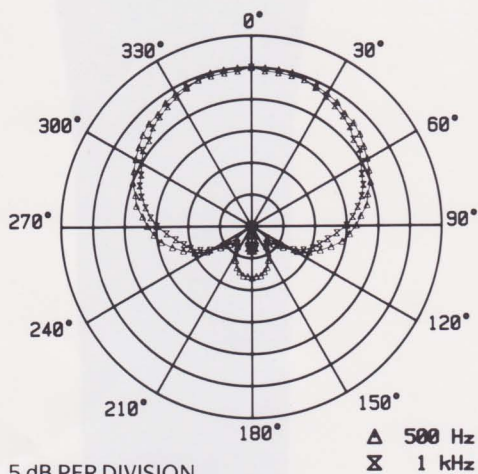

## CERTIFIED PERFORMANCE

Every N/D357A is inspected by a quality-control tester and subjected to a computer-controlled test system that verifies many different performance parameters. After the performance meets or exceeds our rigorous standards, the actual measured frequency response of the unit tested is plotted on a "Certificate of Performance" and included with the microphone. This certificate guarantees that each N/D357A will perform to the exacting standards established by EV design engineers — **100% quality-assurance testing.**

## WARRANTY (LIMITED) —

Electro-Voice N/D<sup>®</sup> Series II Microphones are guaranteed against malfunction from any cause for a period of two years from date of original purchase. Also, these microphones are guaranteed without time limit against malfunction in the acoustic system due to defects in workmanship and material. Any active electronics incorporated in the microphone are guaranteed for three years from date of original purchase for parts and labor against such malfunction. If such malfunction occurs, microphone will be repaired or replaced (at our option) without charge for materials or labor if delivered prepaid to the proper Electro-Voice service facility. Unit will be returned prepaid. Warranty does not extend to finish, appearance items, cables, cable connectors, switches, or malfunction due to abuse or operation under other than specified conditions, nor does it extend to incidental or consequential damages. Some states do not allow the exclusion or limitation of incidental or consequential damages, so the above exclusion may not apply to you. Repair by other than Electro-Voice or its authorized service agencies will void this guarantee. A list of authorized service centers is available from Electro-Voice, Inc., 600 Cecil Street, Buchanan, MI 49107 (AC/616-695-6831) (FAX: 616-695-1304); or Electro-Voice West, 8234 Doe Avenue, Visalia, CA 93291 (AC/209-651-7777) (FAX: 209-651-0164). This warranty gives you specific legal rights, and you may also have other rights which vary from state to state.



**ELECTRO-VOICE, INC., 600 Cecil Street, Buchanan, Michigan 49107**

MANUFACTURING PLANTS AT ■ BUCHANAN, MI ■ NEWPORT, TN ■ SEVIERVILLE, TN ■ GANANOQUE, ONT.  
© Electro-Voice, Inc. 1989 ■ Litho In U.S.A. Part Number 531485-947

a MARK IV company

# N/D<sup>®</sup> Series II

# 357A, 357AS

**Electro-Voice<sup>®</sup>**  
a MARK IV company

## Supercardioid Dynamic Vocal Microphone

The Electro-Voice N/D357A is a supercardioid dynamic microphone utilizing a revolutionary neodymium alloy to form the EV-exclusive N/DYM<sup>®</sup> magnet with four times the power potential of conventional microphone magnets. With a computer-optimized design, the N/DYM magnetic structure provides unprecedented sensitivity while the more uniform magnetic field lowers distortion during peak sound pressure levels.

The large diaphragm contains 50 percent more surface area than conventional designs and is reinforced to prevent "breakup." The result is an extended high-frequency response with an open, transparent sound quality.

The exceptional sensitivity of the N/D357A combined with the inherently low noise of a dynamic transducer insures a superior signal-to-noise ratio ready for digital recording and sampling. To further reduce noise, a highly effective hum-bucking coil is used to cancel hum from lighting and other sources.

N/DYM<sup>®</sup> Series II microphones feature DynaDamp<sup>™</sup>, an advanced vibration-isolation material. DynaDamp<sup>™</sup> is a unique foamed elastomer, specifically formulated for vibration control. Combining DynaDamp<sup>™</sup> with the elastomeric Warm-Grip<sup>™</sup> handle and windscreen bumper forms an advanced technology vibration-isolation system which dramatically reduces all forms of handling noise for the most demanding situations.

The N/DYM<sup>®</sup> Series II pop filter incorporates a special molded retainer which insures optimum placement of the Acoustifoam<sup>™</sup> filter material, for maximum rejection of both wind noise and vocal P-pops. The retainer makes the pop filter an integral part of the microphone's removable upper grille assembly, allowing easy cleaning for continued top performance.

The uniform supercardioid polar pattern of the N/D357A insures superior gain-before-feedback in live applications and better isolation in the studio—at all frequencies—compared with other directional microphones with widely varying polar characteristics.



### FREQUENCY RESPONSE

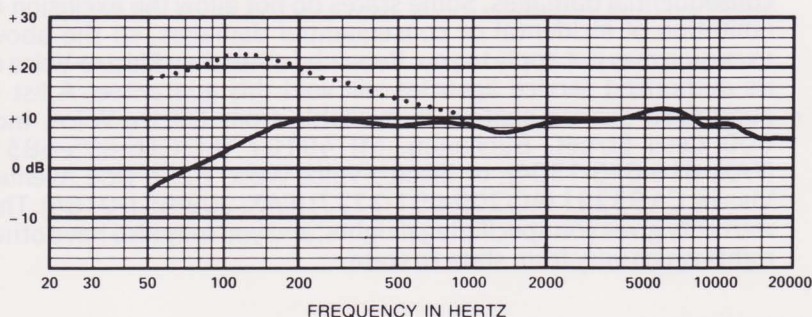

... Close Response