

N/D868

Electro-Voice®

N/DYM® Bass Drum Microphone



Reproducing the sound of a bass drum isn't an easy task. The large size of the drum, high SPL's, air movement and low-frequency vibration all present problems to ordinary microphones. The new Electro-Voice N/D868 was designed for one purpose: to be the very best bass drum microphone available. It provides a unique, high-performance solution to difficult bass-drum-miking problems.



Electro-Voice®
a MARK IV company

N/D868

Electro-Voice®
N/DYM® Bass Drum Microphone

The N/D868 is a true large-diaphragm microphone for extended low-frequency response. Its superb pattern control minimizes off-axis coloration and feedback from large, loud floor monitors. Its wide-range N/DYM® transducer can handle outrageous SPLs without difficulty and has been sensitivity-adjusted to prevent high-level signals from overloading your mic preamp.

The optimal placement for the N/D868 is on a pillow inside the drum about 3-inches from the head. This placement accentuates the "pillow effect"—a 3 to 4-dB drop in the upper bass range—and lets the N/D868's specially tailored response work its magic. The N/D868 has a peak in the upper midrange to capture the attack of the beater on the head and a bump in the 50 to 60-Hz range for solid bass fundamentals that really get people's feet moving. The N/D868's sound is solid and powerful, yet has superb definition!

Like all Electro-Voice microphones, the N/D868 approaches indestructibility. Its special Memraflex™ grille screen resists bumps, dents and bends. Its heavy-duty steel case will survive the most grueling tours with ease. The N/D868's robust stand clamp will hold it securely in place to make it easy to get the sound you desire.

The N/D868 is carefully built to exacting standards in our ISO-certified Sevierville, Tennessee factory. Every microphone is tested and a response graph included with each unit to show it meets all of its engineering criteria. Its two-year unconditional/limited lifetime warranty (see our warranty statement for details) is a testament to its excellent construction and unparalleled design quality.

The N/D868 isn't the first bass drum mic on the market, just the best. It's another great Electro-Voice product designed to help you sound your best.

Specifications

Frequency Response:

20 - 10,000 Hz

Polar Pattern):

Cardioid variant

Open Circuit Voltage 1 kHz:

1 mV/pascal

Power Sensitivity 1 kHz,

(0 dB = 1 mW/pascal):

-51.7 dB

Dynamic Range:

140.3 dB

Polarity:

Positive pressure on diaphragm causes positive voltage on pin 2 ref. pin 3

Impedance:

150 ohms, balanced (low-Z)

Dimensions:

Height: 132.6 mm (5.22 in.)

Diameter: 60 mm (2.36 in.)

Net Weight: 295 g (10.4 oz)

Shipping Weight: 750 g (26.5 oz)

Dimensions

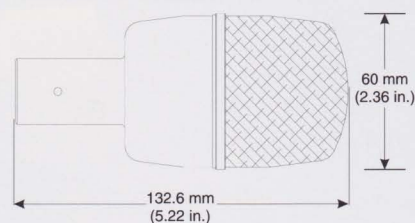

Frequency Response (typical)

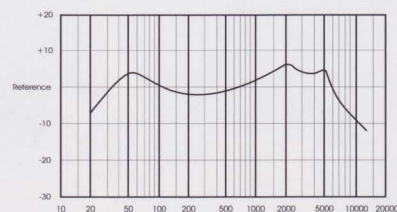

Polar Response (typical)

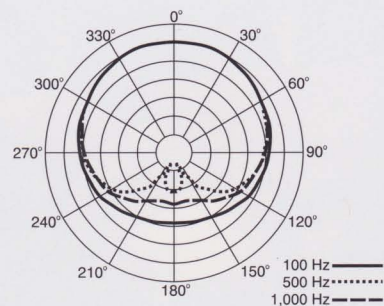

Electro-Voice® a MARK IV company

600 Cecil Street, Buchanan, Michigan 49107, Phone 616/695-6831, 800/234-6831, Fax: 616-695-1304

Mark IV Audio Canada, Inc., 345 Herbert St., Gananoque, Ontario, Canada K7G 2V1, Phone 613/382-2141, Fax 613/382-7466

Mark IV Audio Switzerland, Keitenstrasse 11, CH-2563 IPSACH, Switzerland, Phone 011-41-32-51-6833, Fax 011-41-32-51-1221

Mark IV Audio Deutschland, Hirschberger Ring 45, D-94302, Straubing, Germany, Phone 011-49/9421-7060, Fax 011-49/9421-706265

Mark IV Audio France, S.A., Parc de Courcerin—Allée Lech Walesa, Lognes, f-77185 Marne La Vallée, France, Phone 011-33/1-6480-0090, Fax 011-33/1-6006-5103

Mark IV Audio Japan Ltd., 2-5-60 Izumi, Suginami-ku, Tokyo, Japan 168, Phone 011-81/3-3325-7900, Fax 011-81/3-3325-7789

Mark IV Audio (Aust.) Pty. Ltd., Unit 24, Block C, Slough Business Park, Slough Ave., Silverwater, N.S.W. 2141, Australia, Phone 011-61/2-648-3455, Fax 011-61/2-648-5585

Mark IV Audio Hong Kong, Unit E & F, 21/F., Luk Hop Industrial Bldg., 8 Luk Hop St., San Po Kong, Kowloon, Hong Kong, Phone 011-852/351-3628, Fax 011-852/351-3329