



PI6415

Horn-Loaded, Full-Range, Three-Way Module for Permanent Installation

- High-output/high-quality music and speech for stadiums and performing-arts venues
- Modular for easy and flexible configuration
- Large, correctly sized horn mouths provide uniform directivity control to 500 Hz, for increased intelligibility under difficult acoustic conditions
- Rotatable coaxial mid-bass/high-frequency module
- EVX-150A woofer for high-impact, high-reliability bass
- Integral suspension system for safe and easy installation
- Metal grilles protect components
- Paintable, black primed plywood enclosure

SPECIFICATIONS

Typical Axial Frequency Response (swept one-third-octave pink noise, anechoic environment, 4 volts at 10 feet, normalized for 1 watt, 1 meter into mid-bass driver; see Figure 1):

50-20,000 Hz

Low-Frequency 3-dB-Down Point:

50 Hz

Usable Low-Frequency Limit (10-dB-down point):

40 Hz

Recommended Crossover Frequencies:

160 Hz, 1,600 Hz

Crossover Slopes per Octave, Suggested:

24 dB

Recommended Signal Delay,

Low Frequency: 0.30 msec

Mid Bass: 0.00 msec

High Frequency: 0.60 msec

Long-Term Average Power-Handling

Capacity (see Power-Handling Test section),

Low Frequency

(per ANSI/EIA RS-426-A):

600 watts

Mid Bass

(per ANSI/EIA RS-426-A):

300 watts

High Frequency

(per AES2-1984/ANSI S4.26-1984):

60 watts

Sensitivity (SPL at 1 meter, 1 watt input, anechoic environment, band-limited pink-noise signal),

Low Frequency: 100 dB

Mid Bass: 107 dB

High Frequency: 111 dB

Impedance,

Nominal (low frequency/mid bass/high frequency):

8 ohms/16 ohms/8 ohms

Minimum (low frequency/mid bass/high frequency):

7 ohms/11 ohms/6 ohms

Average Efficiency,

Low Frequency:

5%

Mid Bass:

25%

High Frequency:

25%

Maximum Long-Term Average Mid-Band Acoustic Output:

75 watts

Beamwidth (angle included by 6-dB-down points on polar responses, indicated one-third-octave bands of pink noise; see Figure 2),

400 to 20,000 Hz Horizontal:

60° (+20°, -20°)

600 to 20,000 Hz Vertical:

40° (+15°, -15°)

Directivity Factor R_0 (Q), 500- to 20,000-Hz Median (see Figure 3):

23.4

Directivity Index D_i , 500- to 20,000-Hz Median (see Figure 3):

13.7 dB (+1.6 dB, -2.8 dB)

Distortion (120 dB SPL at 1 meter from mid-bass horn using typical music spectrum; see Figure 4),

Second Harmonic,

100 Hz: less than 1%

1,000 Hz: less than 1%

10,000 Hz: less than 1%

Third Harmonic,

100 Hz: less than 1%

1,000 Hz: less than 1%

10,000 Hz: less than 1%

Transducer Complement,

Low Frequency:

EVX-150A 38.1-cm (15-in.) woofer in a SubScoop™ enclosure

Mid Bass:

DL10X-SH 25.4-cm (10-in.) driver with Kevlar® epoxy composite cone on rotatable MH640 60° x 40° horn¹

High Frequency:

DH2As2 compression driver on HP64

60° x 40° horn coaxially mounted to mid-bass horn

Polarity (all drivers):

A positive voltage applied to the positively marked input terminal produces a positive acoustic pressure at the front of the system

Input Connections, Low Frequency/

Mid Bass/High Frequency:

Screw terminals (#10) on barrier strip; each driver can be individually accessed; high-frequency driver has blocking capacitor for protection

Enclosure Materials and Color:

Black primed multilayer plywood

Grille:

Two-piece, black vibration-resistant steel, removable

Suspension:

Integral four-point flying system (accepts Ankra 42546-10 single-stud tie-down cargo fitting; four fittings supplied with system; see Suspending PI6415 Enclosure section)

Dimensions,

Height:

146 cm (57.3 in.)

Width:

74.9 cm (29.5 in.)

Depth:

77.0 cm (30.3 in.)

Net Weight:

102 kg (225 lb)

Shipping Weight:

113 kg (250 lb)

Packing:

Wooden pallet and carton

DESCRIPTION

The Electro-Voice PI6415 is a three-way horn-loaded speaker system for permanent installation, part of the PI series of modular systems. The PI series is unique because it combines concert sound performance and quality with the directivity control formerly associated only with

1. Kevlar® is a registered trademark of DuPont.

PI6415 SPECIFICATION GRAPHICS

FIGURE 1 — Typical Axial Frequency Response (anechoic environment, 1 watt/1 meter into mid-bass section)

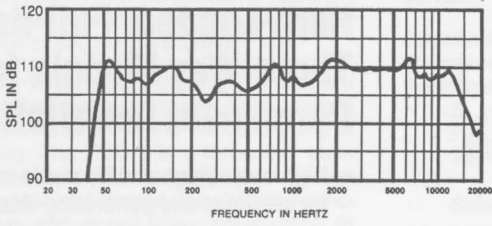

FIGURE 2 — Beamwidth vs. Frequency

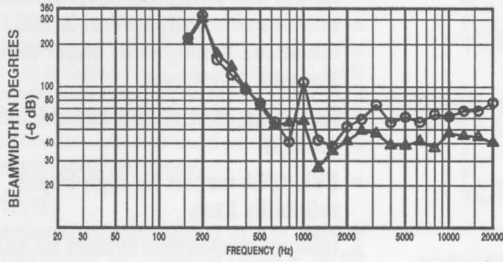

FIGURE 3 — Directivity Factor and Directivity Index vs. Frequency

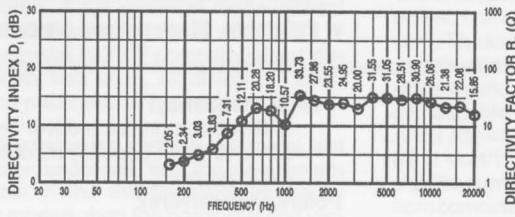

FIGURE 4 — Harmonic Distortion (120 dB SPL at one meter from mid-bass horn using typical music spectrum)

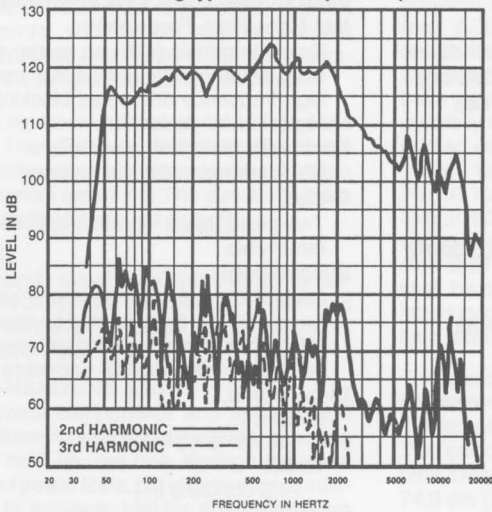

FIGURE 5 — Module Rotation

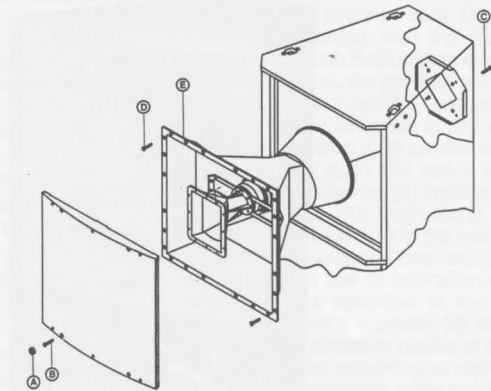
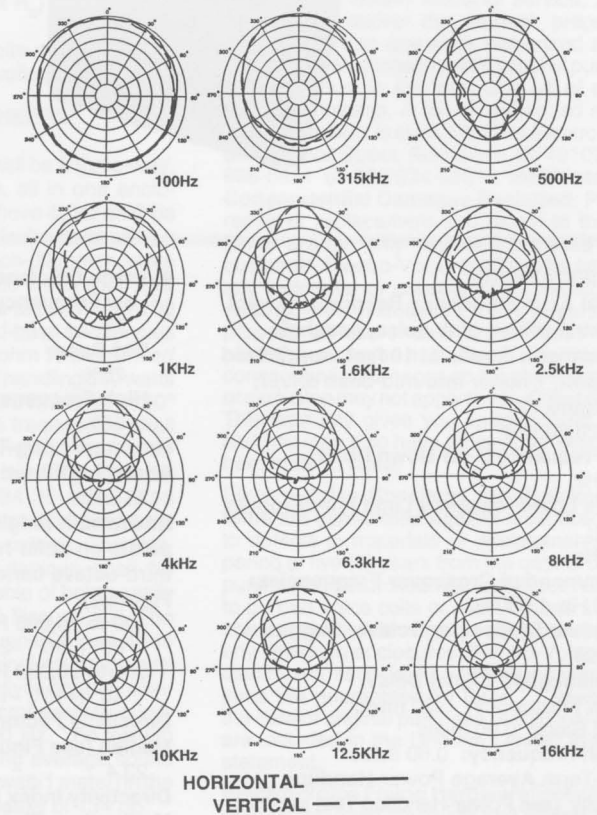

FIGURE 6 — Polar Response



large-format constant-directivity horns used in "traditional," two-way arrays crossed over at 500 Hz.

The PI series provides uniform directivity control down to 500 Hz, because the mouth dimensions of both the mid-bass and high-frequency horns were correctly chosen and are large enough with respect to the wavelengths reproduced to do so. The PI series' superior directivity control increases speech intelligibility and musical clarity in difficult acoustic environments. **Other three-way systems with smaller radiating areas simply cannot provide the high degree of directional control associated with the PI series.**

The PI6415 and the other models in the PI series were specifically designed with the contractor and sound system consultant in mind. The PI series allows the designer to customize his system to suit any acoustic environment.

The PI6415 is a 60° x 40° three-way full-range module for triamp application. The mid-bass and high-frequency horns are coaxially mounted and are easily rotated together, allowing the horizontal and vertical coverage patterns to be interchanged. The common acoustic axes of the mid-bass and high-frequency horns ensure smooth response and coverage in the cross-over region when the appropriate signal delay is applied to the high-frequency driver. The horn-loaded bass section incorporates an EVX-150A 38.1-cm (15-in.) woofer for maximum output and reliability. The combination of rotatable horns and trapezoidal enclosure shape allows easy construction of circular and spherical arrays. The angled enclosure sides allow ceiling mounting with a reduced vertical profile and an aiming angle that is inherently in the general direction of the audience. The enclosure is made of black painted, multilayer plywood and includes certified flying hardware as standard.

Delivering smooth and extended performance, the high-frequency section operates from 1,600 to 20,000 Hz and consists of a specially developed, low-profile DH2As2 compression driver coupled to an HP64 60° x 40° constant-directivity horn. The HP64 horn features integral fiberglass-and-zinc construction for exceptional strength and performance. Beamwidth-control vanes in the horn throat correct all coverage anomalies in the 10- to 20-kHz octave. This horn and driver combination is securely mounted to the mid-bass horn by a heavy-duty steel bracket.

The mid-bass system is composed of a DL10X-SH 24.5-cm (10-in.) reproducer mounted on an MH640 60° x 40° mid-bass horn. The DL10X-SH reproducer contains a Kevlar® epoxy cone, which is twice as strong as the conventional paper cone.¹ The mid-bass section operates between 160 and 1,600 Hz, and features a proprietary phase plug (U.S. patent no. 4,718,517) which extends the high-end output to blend seamlessly into the coaxial high-frequency section.

The low-frequency section operates between 50 and 160 Hz and has been designed for superior performance, in the air as well as on the ground. The EVX-150A woofer can handle very large levels of input power, producing high acoustic output with relatively low distortion and closely matching the high output levels of the high- and mid-frequency sections.

The PI6415 is equipped with a number of additional features to make operation and installation easy and secure. A proprietary structural extrusion is incorporated into the enclosure, providing safe and flexible suspension (see Suspending PI6415 section). Up to two enclosures (from any of the PI series family) can be suspended without additional support, so arrays can be created quickly and easily. The mid-bass/high-frequency module can be rotated easily on site within the trapezoidal enclosure, allowing for an infinite combination of coverage angles and patterns. The two grilles are composed of vibration-resistant steel for excellent driver protection, and they can be painted to blend into any environment. The enclosure can also be painted using ordinary paints. All wiring on the PI6415 mid-bass/high-frequency module is integral and rotates with the horns, so wiring errors are minimized; all drivers can be serviced from the front of the enclosure. The PI6415, in its standard form, is intended for use indoors. Do not use outdoors.

APPLICATIONS

The PI6415 and the PI series of products have been designed specifically with the permanent installation market in mind. Sports arenas, performing arts centers, auditoriums and large gymnasiums are all candidates for the PI6415 and the entire PI line. The unique modular construction and optimized bass performance combined with superior directivity control result in a system that can be used in almost any situation. The concert-sound pedigree of the PI series is evident by the ease of installation and by the use of professional-grade components throughout the line.

SUSPENDING PI6415 ENCLOSURES

Suspending any object is potentially dangerous and should only be attempted by individuals who have a thorough knowledge of the techniques and regulations of rigging objects overhead. Electro-Voice strongly recommends that the PI6415 be suspended taking into account all current national, federal, state and local regulations. It is the responsibility of the installer to ensure the PI6415 is safely installed in accordance with all such regulations. If the PI6415 is suspended, Electro-Voice strongly recommends that the system be inspected at least once a year. If any sign of weakness or damage is detected, remedial action should be taken immediately.

A manual entitled *Installing the PI Series* is available from Electro-Voice. It is included with every PI system and should be followed carefully. A general overview is included here to help the system designer. This overview does not replace the *Installing the PI Series* manual, which includes additional information on suspending, configuring and equalizing the PI series.

The PI series enclosures are suspended using the following approach, which has been approved by an independent structural engineer. Every enclosure incorporates eight independent suspension points, four on the top and four on the bottom. A minimum of four points must be used at all times to suspend the enclosure. The suspension points, which "tie" the top and sides of the enclosure together, are made of structural aluminum. Each suspension point mates to an Ancra 42546-10 locking fitting²,

(four of which are supplied with every enclosure), and each point has a break strength of 907 kg (2,000 lb) in any direction. A maximum of two enclosures can be "daisy-chained" together, allowing the construction of vertical arrays. If longer arrays are required, provision must be made to independently suspend each enclosure. The Ancra 42546-10 fitting incorporates a safety pin to prevent accidental release, and it should be engaged at all times.

CAUTION: The PI6415 speaker systems should be suspended overhead only in accordance with the procedures and limitations specified in the installation manual included with the systems.

MODULE ROTATION

The mid-bass/high-frequency module is shipped with the 60° coverage pattern horizontal (when the long system axis is vertical). The module can be rotated through 90° (see Figure 5) by the following procedure:

1. Remove the mid/high grille assembly by removing the black hole caps (Item A) and then, using a Phillips screwdriver, removing the four 10-24 screws (Item B).
2. Remove the four 1/4-20 hex-head screws (Item C) from the back of the enclosure.
3. Using a Phillips screwdriver, remove sixteen 10-24 screws (Item D) from around the horn rim. *The enclosure may be laid on its back at this time for easiest servicing; however, this is not strictly necessary.*
4. Pull the mid-bass/high-frequency module (Item E) forward and rotate through 90°.
5. Relocate the mid/high-frequency module in the steel nest. *In some circumstances, it may be necessary to loosen the steel nest to relocate the module.*
6. Reverse the procedure to reassemble the system. Screws should be tightened down firmly, but do not overtighten.

CONNECTIONS

Each frequency section can be individually connected via #10 screw terminals. The mid- and high-frequency connections are located together on the back at the top of the enclosure. The low-frequency connection is located separately, on the back at the bottom of the enclosure. All drivers are connected with the same polarity. A positive voltage applied to the positively marked terminal produces a positive acoustic pressure at the front of the system.

CROSSOVER, EQ AND SIGNAL DELAY

The PI6415 is a three-way system which must be triamped with a separate active crossover. 24-dB-per-octave crossover slopes are assumed for maximum performance and reliability. For optimum performance, each section also requires individual EQ and signal delay. (Note: the delays noted below are for fourth-order (24-dB-per-octave) Linkwitz-Riley crossover filter characteristics.) The low-frequency section should have subpassband protection using a high-pass filter set at about 30 Hz and be crossed over at 160 Hz. No signal delay or further EQ is needed but can be applied at the discretion of the designer or installer. A 0.3-msec signal delay provides the smoothest response in the crossover region. The mid-bass section should be crossed over to match the low-frequency section and at 1,600 Hz at the

2. For additional information, contact Ancra International at 606/371-7272 or toll free (within the U.S. only) at 800/233-5138.

1. Kevlar® is a registered trademark of Dupont.

high end. No signal delay or overall broadband EQ is required. The high-frequency section requires a 1,600-Hz crossover and the typical constant-directivity-horn high-frequency boost EQ. A 0.6-msec signal delay provides the smoothest response in the crossover region. A low-frequency blocking capacitor with a 3-dB-down point of 800 Hz is included.

An Electro-Voice XEQ-3 electronic crossover/ equalizer/time delay unit with EQW plug-in module provides all of the necessary signal processing. The XEQ-3 is a three-way electronic crossover with adjustable crossover frequencies utilizing Linkwitz-Riley 24-dB-per-octave filters and signal delay equalization to achieve zero lobbing error.

FREQUENCY RESPONSE

The PI6415 axial frequency response was measured in Electro-Voice's large anechoic chamber at a distance of 3.0 meters (10 feet) with a swept sine-wave input (see Figure 1). It has been normalized for 1 watt/1 meter into the mid-bass section. Minimal level adjustment and equalization have been used.

DIRECTIVITY

The directional characteristics of the PI6415 were measured in Electro-Voice's large anechoic chamber, with a test signal of one-third-octave filtered pink noise at the frequencies indicated. A full spherical measurement system, which is fully compatible with MARK IV Audio's AcustaCADD™ computer-aided design program, was used. All directional information was measured at 6.1 meters (20 feet).

Figure 6 illustrates the nominal horizontal and vertical polar responses, with the long system axis vertical. If the mid-bass/high-frequency module is rotated, then the horizontal and vertical polars should be interchanged.

Figure 2 illustrates the horizontal and vertical beamwidths. Beamwidth is the angle at which the horizontal and vertical polar responses have decreased in level by 6 dB when compared to the on-axis frequency response.

Figure 3 represents the total directivity of the PI6415. The directivity factor R_0 (Q) is the relative value, at a point, when compared to an ideal spherical response. The directivity index (D_i) is calculated by $D_i = 10 \log_{10} R_0$.

SERVICE

In the unlikely event the PI6415 requires service, each driver can be replaced or serviced from the front. A service data sheet is available from Electro-Voice.

POWER-HANDLING TEST

Electro-Voice components and systems are manufactured to exacting standards, ensuring they will hold up, not only through the most rigorous of power tests, but also through continued use in arduous, real-life conditions. Two main test specifications are used: the AES Recommended Practice for Specification of Loudspeaker Components Used in Professional Audio and Sound Reinforcement (AES2-1984/ANSI S4.26-1984) and the EIA Loudspeaker Power Rating Full Range (ANSI/EIA RS-426-A 1980). Both of these specifications use random-noise spectrums which mimic typical music and test the thermal and mechanical capabilities of the components. Electro-Voice will

support relevant additional standards as and when they become available. Extreme, in-house power tests, which push the performance boundaries of the components, are also performed and passed to ensure years of trouble-free service.

Specifically, the PI6415 high-frequency section passes AES2-1984/ANSI S4.26-1984 with the following values:

$Z_{MIN} = 6.0$ ohms at 7,000 Hz
 $P_{E(MAX)} = 60$ watts
Test voltage = 19.0 volts rms,
38.0 volts peak (+6 dB)
Selected decade = 1,500-15,000 Hz

The PI6415 mid-bass section passes ANSI/EIA RS-426-A 1980 with the following values:

$R_{SR} = 6.9$ ohms ($1.15 \times R_E$)
 $P_{E(MAX)} = 300$ watts
Test voltage = 45.5 volts rms,
91.0 volts peak (+6 dB)

The PI6415 low-frequency section passes ANSI/EIA RS-426-A 1980 with the following values:

$R_{SR} = 6.7$ ohms ($1.15 \times R_E$)
 $P_{E(MAX)} = 600$ watts
Test voltage = 63.3 volts rms,
126.5 volts peak (+6 dB)

ARCHITECTS' AND ENGINEERS' SPECIFICATIONS

The loudspeaker module shall be a three-way, active, horn-loaded system, all in one enclosure. The low frequencies above 40 Hz shall be reproduced by an 8-ohm 15-inch woofer with an edge-wound, flat-wire 4-inch-diameter voice coil capable of handling 600 watts (per EIA/ANSI RS-426-A) and with a sensitivity of 100 dB (1 watt/1 meter). The mid-bass frequencies shall be reproduced by a 16-ohm 10-inch driver/horn combination capable of handling 300 watts (per ANSI/EIA RS-426-A) and with a 60° x 40° coverage pattern. The high frequencies shall be reproduced by an 8-ohm 2-inch-exit compression driver capable of handling 60 watts (per AES2-1984/ANSI S4.26-1984) and coupled to an HP64 constant-directivity horn with a 60° x 40° coverage pattern. The mid-bass and high-frequency devices shall be coaxially mounted and capable of being easily rotated within the enclosure through 90°. The system will reproduce frequencies from 40 to 20,000 Hz and have a nominal coverage pattern of 60° x 40°, with directivity control maintained down to 500 Hz. The crossover frequencies shall be 160 and 1,600 Hz. The system shall be capable of producing average sound levels in excess of 128 dB (1 watt/1 meter) in the long term, with short-term peaks of 134 dB.

The enclosure shall be constructed of black-primed, multilayer plywood and have two metal grilles, each of which attaches with four screws. The enclosure shall have a trapezoidal footprint. Dimensions shall be 146 cm (57.3 in.) tall, 74.9 cm (29.5 in.) wide, and 77.0 cm (30.3 in.) deep. Weight shall be 102 kg (225 lb). The enclosure shall incorporate as standard a method of suspension which allows the safe and flexible suspension of itself and one other member of the PI series family using Ancre fitting 42546-10.

The loudspeaker system shall be the Electro-Voice PI6415.

UNIFORM LIMITED WARRANTY

Electro-Voice products are guaranteed against malfunction due to defects in materials or workmanship for a specified period, as noted in the individual product-line statement(s) below, or in the individual product data sheet or owner's manual, beginning with the date of original purchase. If such malfunction occurs during the specified period, the product will be repaired or replaced (at our option) without charge. The product will be returned to the customer prepaid. **Exclusions and Limitations:** The Limited Warranty does not apply to: (a) exterior finish or appearance; (b) certain specific items described in the individual product-line statement(s) below, or in the individual product data sheet or owner's manual; (c) malfunction resulting from use or operation of the product other than as specified in the product data sheet or owner's manual; (d) malfunction resulting from misuse or abuse of the product; or (e) malfunction occurring at any time after repairs have been made to the product by anyone other than Electro-Voice or any of its authorized service representatives. **Obtaining Warranty Service:** To obtain warranty service, a customer must deliver the product, prepaid, to Electro-Voice or any of its authorized service representatives together with proof of purchase of the product in the form of a bill of sale or receipted invoice. A list of authorized service representatives is available from Electro-Voice at 600 Cecil Street, Buchanan, MI 49107 (616/695-6831 or 800/234-6831). **Incidental and Consequential Damages Excluded:** Product repair or replacement and return to the customer are the only remedies provided to the customer. Electro-Voice shall not be liable for any incidental or consequential damages including, without limitation, injury to persons or property or loss of use. Some states do not allow the exclusion or limitation of incidental or consequential damages so the above limitation or exclusion may not apply to you. **Other Rights:** This warranty gives you specific legal rights, and you may also have other rights which vary from state to state.

Electro-Voice Speakers and Speaker Systems are guaranteed against malfunction due to defects in materials or workmanship for a period of five (5) years from the date of original purchase. The Limited Warranty does not apply to burned voice coils or malfunctions such as cone and/or coil damage resulting from improperly designed enclosures. Electro-Voice active electronics associated with the speaker systems are guaranteed for three (3) years from the date of original purchase. Additional details are included in the Uniform Limited Warranty statement.

Electro-Voice Flying Hardware (including enclosure-mounted hardware and rigging accessories) is guaranteed against malfunction due to defects in materials or workmanship for a period of one (1) year from the date of original purchase. Additional details are included in the Uniform Limited Warranty statement.

Electro-Voice Accessories are guaranteed against malfunction due to defects in materials or workmanship for a period of one (1) year from the date of original purchase. Additional details are included in the Uniform Limited Warranty statement.

Service and repair address for this product: Electro-Voice, Inc., 600 Cecil Street, Buchanan, Michigan 49107 (616/695-6831 or 800/234-6831).

Specifications subject to change without notice.



ELECTRO-VOICE a MARK IV company 600 Cecil Street, Buchanan, Michigan 49107

MANUFACTURING PLANTS AT ■ BUCHANAN, MI ■ NEWPORT, TN ■ SEVIerville, TN ■ OKLAHOMA CITY, OK ■ GANANOQUE, ONT.
© Electro-Voice, Inc. 1994 ■ Litho in U.S.A.

Part Number 532120 — 9411