



PIM-102

(standard configuration)

10-inch Two-Way System for Permanent Installation, Horn-Loaded HF

- Part of PI Matrix Series™—compact trapezoidal systems for permanent installation
- Passive (standard) or for bi-amplification
- Very compact
- Components and physical characteristics optional, to meet many acoustic, architectural and mechanical requirements
- 85-Hz low end for speech and supplemental music applications
- Two HF coverages—60° x 40° or 90° x 40° (standard)
- PRO™ circuit HF protection
- Integral suspension system for safe and easy installation

SPECIFICATIONS

Versions Available:

See PIM-102 ordering matrix (Figure 1)

Typical Axial Frequency Response (swept sine-wave input, anechoic environment, 4 volts at 10 feet; see Figure 2):

85-18,000 Hz

Low-Frequency 3-dB-Down Point:

85 Hz

Usable Low-Frequency Limit (10-dB-down point):

56 Hz

Recommended Crossover Frequency:

1,800 Hz

Crossover Slopes,

Recommended:

12 dB per octave

Minimum:

12 dB per octave

Long-Term Average Power-Handling Capacity,

Low Frequency :

150 watts

High Frequency:

20 watts

Overall System with Passive Crossover (per EIA RS-426-A 1980; see Power-Handling Test section):

150 watts

Sensitivity (far-field SPL referred to 1 meter, 1-watt input, anechoic environment, band-limited pink noise),

Low Frequency (100-800 Hz):

96 dB

High Frequency (500-5,000 Hz):

112 dB

Overall System with Passive Crossover (200-2,000 Hz):

97 dB

SPL at Full Power (far-field SPL at 1 watt/ 1 meter referred to full power, anechoic environment, band-limited pink noise),

Long-Term Average/Peak,

Low Frequency (100-800 Hz):

118 dB/124 dB

High Frequency (500-5,000 Hz):

125 dB/131 dB

Impedance,

Nominal :

8 ohms

Minimum:

6.7 ohms

Average Efficiency,

Low Frequency: 2.6%

High Frequency: 25%

Nominal Coverage Angle,

Horizontal: 90°

Vertical: 40°

Beamwidth (angle included by 6-dB-down points on polar responses, indicated one-third-octave bands of pink noise; see Figure 3):

5,000 to 16,000 Hz Horizontal:

90° (+6°, -1°)

5,000 to 12,000 Hz Vertical:

45° (+5°, -2°)

Directivity Factor R_0 (Q), 5,000- to 16,000-Hz Median (see Figure 5):

10.3 (+12.1, -6.4)

Directivity Index D, 5,000- to 16,000-Hz Median (see Figure 5):

10.1 dB (+10.8 dB, -8.1 dB)

FIGURE 1 — PIM-102 Ordering Matrix

NOTE: Example is the standard system configuration

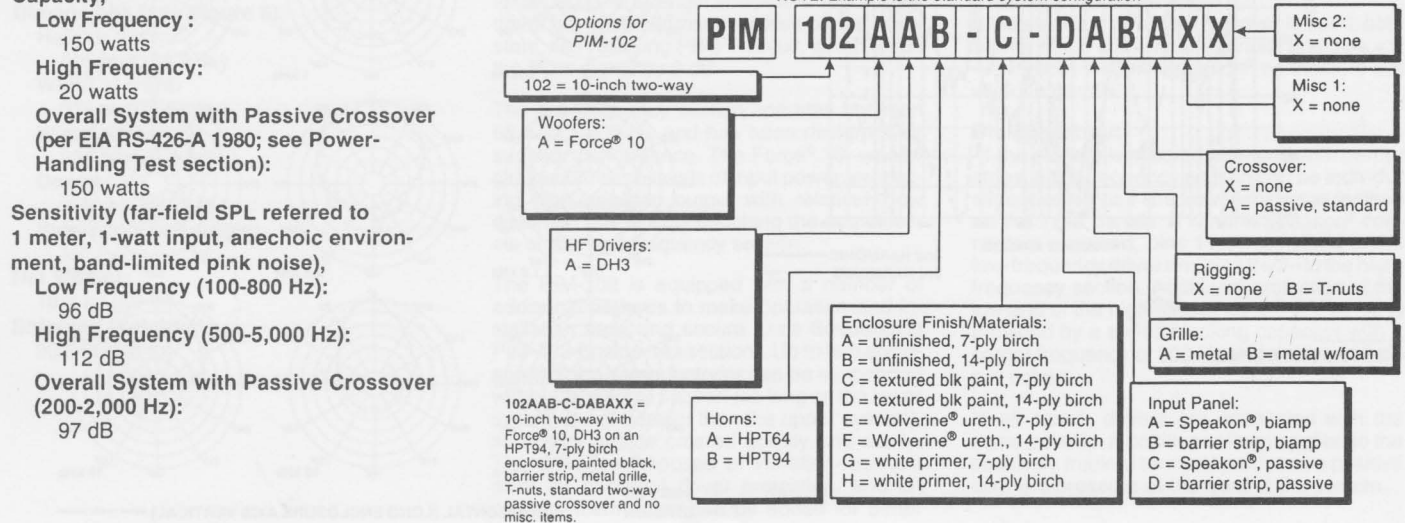

PIM-102 SPECIFICATION GRAPHICS

FIGURE 2 — PIM-102 Typical Axial Frequency Response
(swept sine-wave input, 4 volts at 10 feet on axis, anechoic environment, normalized for 1 watt/1 meter)

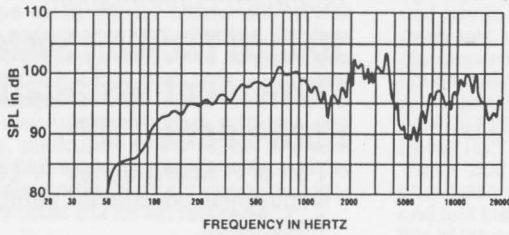

FIGURE 3 — PIM-102 Beamwidth vs. Frequency
(one-third-octave bands of pink noise)

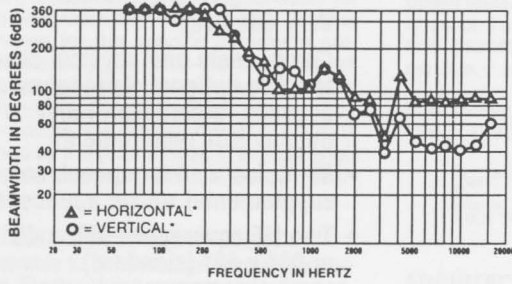

FIGURE 4 — PIM-102 Directivity Factor and Directivity Index vs. Frequency
(one-third-octave bands of pink noise)

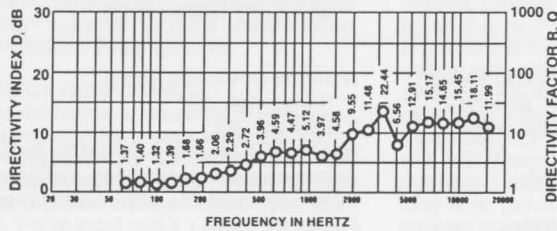
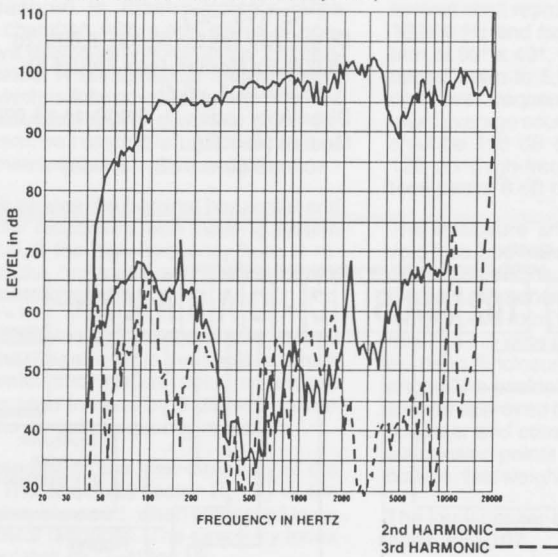

FIGURE 5 — PIM-102 Harmonic Distortion 10% Rated Input Power at 500 Hz (on axis at 1 meter from system)



*Long enclosure axis vertical.

FIGURE 6 — PIM-102 Dimensions

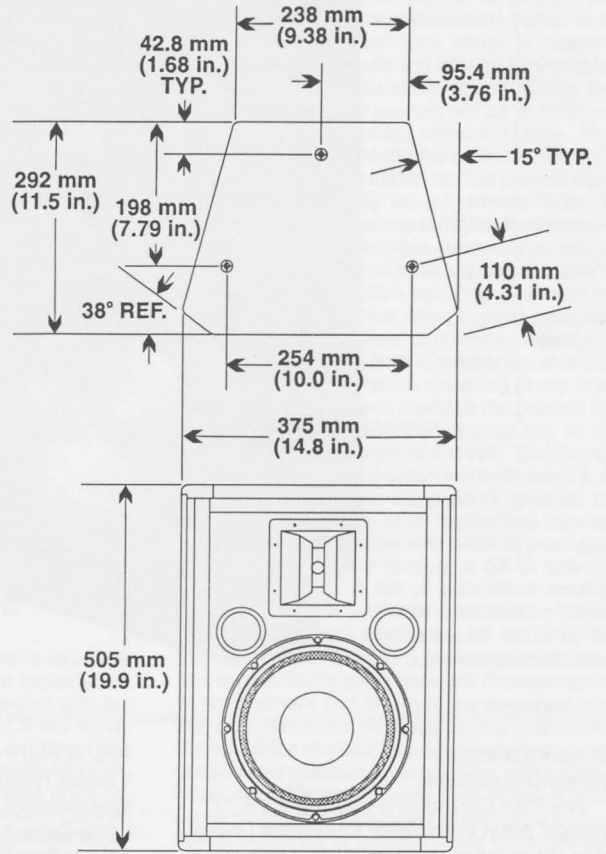
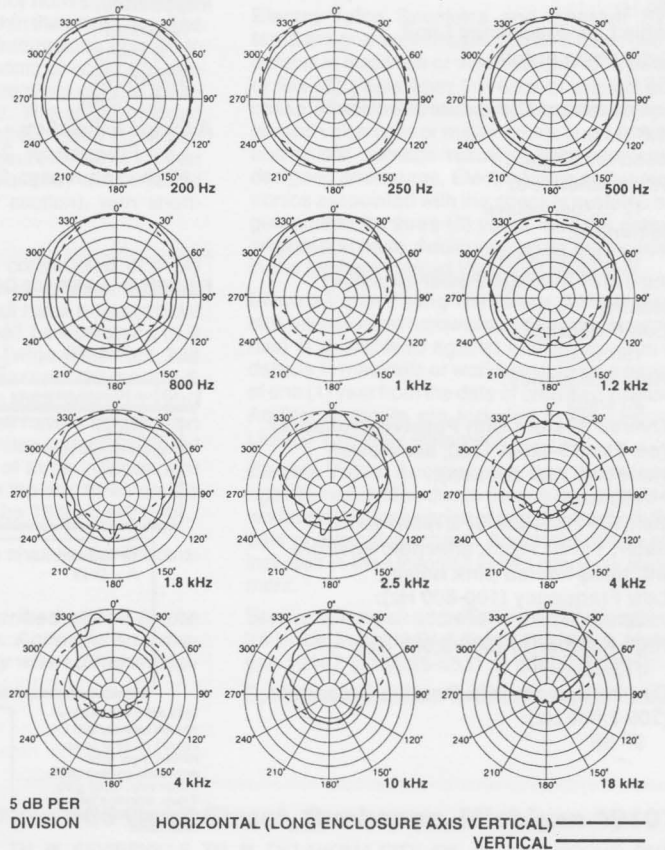

FIGURE 7 — PIM-102 Polar Responses, Selected to Typify Performance
(one-third-octave bands of pink noise)



Distortion Response, 1% Rated Input Power at 500 Hz (on axis at 1 meter from system),

Second Harmonic:

100 Hz: 1.6%
1,000 Hz: <1.0%
10,000 Hz: 1.3%

Third Harmonic,

100 Hz: 1.6%
1,000 Hz: <1.0%
10,000 Hz: <1.0%

Distortion Response, 10% Rated Input Power at 500 Hz (on axis at 1 meter from system; see Figure 6),

Second Harmonic:

100 Hz: 5.0%
1,000 Hz: <1.0%
10,000 Hz: 4.0%

Third Harmonic,

100 Hz: 4.5%
1,000 Hz: <1.0%
10,000 Hz: 1.8%

Transducer Complement,

Low Frequency:

Force® 10 254-mm (10-in.) woofer in a vented enclosure

High Frequency:

HPT-94 90°x40° horn mounted to DH3 compression driver with 25-mm (1-in.) exit

Box Tuning Frequency:

67 Hz

Polarity (all drivers):

A positive voltage applied to the positively marked input terminal produces a positive acoustic pressure at the front of the system

Input Connections, Low Frequency/

High Frequency:

#10 screw terminals on barrier strip; both wired in parallel

Driver Protection, High Frequency:

Solid-state self-resetting circuit (PRO™ circuit) drops input 6 dB

Enclosure Materials and Color:

Textured black painted 7-ply void-free birch

Grille:

Black powder-coated, vibration-resistant steel, removable

Suspension:

Integral three-point flying system (3/8-16 forged steel eye bolt; four fittings supplied with system; see Suspending PIM-102 Enclosures section)

Dimensions (see Figure 6),

Height:

505 mm (19.9 in.)

Width at front:

375 mm (14.8 in.)

Width at rear:

238 mm (9.4 in.)

Depth:

292 mm (11.5 in.)

Side-Wall Draft Angle:

15°

Net Weight:

18.2 kg (40 lb)

Shipping Weight:

20.9 kg (46 lb)

DESCRIPTION AND APPLICATIONS

The Electro-Voice PIM-102 is a very compact, trapezoidal two-way speaker system for permanent installation. The high-frequency section is horn loaded and the low-frequency section is direct radiating in an optimally vented enclosure. The PIM-102 is part of the PI Matrix Series™, a highly flexible group of full-range and low-frequency systems for applications where compact systems are appropriate. Many performing arts centers, clubs, auditoriums, sports facilities and houses of worship are candidates for the PI Matrix Series™.

The flexibility of the PI Matrix Series™ allows the designer to customize a system to both suit the acoustic environment and meet a wide variety of architectural and mechanical requirements. High-frequency horns have been optimally sized to maintain their rated coverage patterns down to the chosen crossover frequencies and over as wide a frequency range as possible. Furthermore, the horns are optionally available in two coverage angles (90° x 40° and 60° x 40°) to aid in properly matching a speaker location to the audience area. In addition, all horns may be rotated about their axes, for coverage that is independent of enclosure orientation.

Other PI Matrix Series™ options include low- and high-frequency drivers, enclosure materials and finish, grilles, suspension hardware and input-panel connections, giving the sound contractor or consultant literally thousands of combinations to satisfy the overall system design criteria.

The PIM-102 standard configuration is a 90° x 40° two-way full-range system with passive crossover for speech and supplemental music applications. The PIM-102 may optionally be ordered without a crossover, for biamplification. The PIM-102 maintains good directivity control down to 5,000 Hz (see Figure 3). The low-frequency section incorporates a Force® 10 254-mm (10-in.) woofer. The angled enclosure sides (15°) allow ceiling or under-balcony mounting with a reduced vertical profile and aiming angle that is inherently in the general direction of the audience. The enclosure is made of black painted 7-ply void-free birch and includes certified flying hardware as standard.

Delivering smooth and extended performance, the high-frequency section operates from 1,800 to 18,000 Hz and consists of a DH3 compression driver coupled to an HPT-94 90° x 40° constant-directivity horn. The HPT-94 horn features integral fiberglass-and-zinc construction for exceptional strength and performance. The driver is protected from overdrive by the solid-state, self-resetting PRO™ circuit, which drops the input signal by 6 dB.

The low-frequency section operates between 65 and 1,800 Hz and has been designed for superior performance. The Force® 10 woofer can handle large levels of input power, producing high acoustic output with relatively low distortion and closely matching the output levels of the high-frequency section.

The PIM-102 is equipped with a number of additional features to make operation and installation easy and secure. (see Suspending PIM-102 Enclosures section). Up to two enclosures of the same footprint can be suspended without additional support (as long as the lower system is not heavier than the upper system), so arrays can be created quickly and easily. The grille is composed of vibration-resistant steel for excellent driver protection, and an optional foam cover can be added for better

protection when used outdoors. Besides the standard black-painted finish, the enclosure can also be ordered primed in white for painting with ordinary paints, unfinished for staining, or with our special Wolverine® weather-resistant finish for outdoor applications. All drivers on the PIM-102 can be serviced from the front of the enclosure.

A complete listing of all system options is shown in Figure 1.

SUSPENDING PIM-102 ENCLOSURES

Suspending any object is potentially dangerous and should be attempted only by individuals who have a thorough knowledge of the techniques and regulations of hanging overhead. Electro-Voice strongly recommends that the PIM-102 be suspended taking into account all current national, federal, state and local regulations. It is the responsibility of the installer to ensure the PIM-102 is safely installed in accordance with all such regulations. If the PIM-102 is suspended, Electro-Voice strongly recommends that the system be inspected at least once a year. If any sign of weakness or damage is detected, remedial action should be taken immediately.

The PI Matrix Series™ enclosures are suspended using the following approach, which has been approved by an independent structural engineer. Every enclosure incorporates six independent suspension points, three on the top and three on the bottom. A minimum of three points must be used at all times to suspend the enclosure. The suspension points, which are 3/8-16 T-nuts, are to be used with forged steel eyebolts only (EV part no. 20499). A maximum of two enclosures can be "daisy chained" together, allowing the construction of vertical arrays. If longer arrays are required, provision must be made to independently suspend each enclosure.

ROTATING THE HIGH-FREQUENCY HORN

The PIM-102 high-frequency horn may be easily rotated about its major axis, providing coverage independent of enclosure orientation. First remove the enclosure grille, then the horn. Both are affixed with Phillips-head screws (use a #2 Phillips screwdriver). Rotate the horn 90° about its axis and reinstall the components.

CONNECTIONS

The option ordered, biamped or passive crossover with either barrier-strip or Neutrik Speakon™ connectors, will determine the wiring of the system components.

Passive Crossover Input

If the standard passive crossover is used, both barrier strips are wired in parallel and pins +1/-1 on both Neutrik Speakon® connectors are wired in parallel.

Biamped Input

If the system is ordered biamped with barrier strips, each frequency section can be individually accessed via #10 screw terminals as marked on the input panels. If Neutrik Speakon® connectors are used, pins 1+/1- are wired to the low-frequency driver and pins 2+/2- to the high-frequency section. Additional protection at the low end of the high-frequency driver's range is provided by a series blocking capacitor with a corner frequency of 800 Hz and a slope of 6 dB per octave.

In all cases, drivers are connected with the same polarity. A positive voltage applied to the positively marked terminal produces a positive acoustic pressure at the front of the system.

CROSSOVER, EQ AND SIGNAL DELAY

The PIM-102 is a two-way system which may be ordered without crossover, for bi-amplification. An 1,800-Hz crossover frequency is recommended. The minimum recommended crossover slope of 12 dB per octave will provide optimum performance and reliability. The low-frequency section should have subpassband protection using a high-pass filter set at about 30 Hz. No signal delay or further EQ is mandatory but their use can smooth response and directivity, particularly in the region of crossover. The high-frequency section requires the appropriate constant-directivity-horn high-frequency boost EQ for flat response.

Electro-Voice's Dx34 digital speaker system processor can be set to provide subpassband protection, crossover, EQ and signal delay for optimum performance of the PIM-102. Contact Electro-Voice for the specific parameter settings. Alternatively, the XEQ-2 or XEQ-3 analog crossover/equalizer/delay networks can be used. High-frequency horn EQ is provided by plug-in modules, the specific model of which is determined by the horn model. The XEQ engineering data sheets provide this specific information.

LOW-FREQUENCY ENHANCEMENT

If it is desirable to enhance low-frequency performance, Electro-Voice recommends, depending on installation requirements, the PIM-151 or PIM-251 PI Matrix Series™ systems as well as any of the TL series or MTL series of Manifold Technology® systems. Contact Electro-Voice for information on these systems.

FREQUENCY RESPONSE

PIM-102 axial frequency responses were measured in Electro-Voice's large anechoic chamber at a distance of 3.0 meters (10 feet) with swept sine-wave input. Figure 2 shows the axial frequency response with a 4-volt drive, normalized for a 1-watt input and a 1-meter distance.

DIRECTIVITY

The directional characteristics of the PIM-102 were measured in Electro-Voice's large anechoic chamber, with a test signal of one-third-octave filtered pink noise at the frequencies indicated. A full spherical measurement system, which is fully compatible with Mark IV Audio's AcustaCADD™ computer aided design program, was used. All directional information was measured at 6.1 meters (20 feet).

Figure 7 illustrates the nominal horizontal and vertical polar responses, with the long system axis vertical. If the high-frequency horn is rotated, then the horizontal and vertical polars should be interchanged.

Figure 3 illustrates the horizontal and vertical beamwidths. Beamwidth is the angle at which the horizontal and vertical polar responses have decreased in level by 6 dB when compared to the on-axis frequency response.

Figure 4 represents the total directivity of the PIM-102. The directivity factor R_0 (Q) is the relative value, at a point, when compared to an ideal spherical response. The directivity index (D) is calculated by $D_i = 10 \log_{10} R_0$.

SERVICE

In the unlikely event the PIM-102 requires service, each driver can be replaced or serviced from the front. A service data sheet is available from Electro-Voice.

POWER-HANDLING TEST

Electro-Voice components and systems are manufactured to exacting standards, ensuring they will hold up, not only through the most rigorous of power tests, but also through continued use in arduous, real-life conditions. Two main test specifications are used: the AES Recommended Practice for Specification of Loudspeaker Components Used in Professional Audio and Sound Reinforcement (AES2-1984/ANSI S4.26-1984) and the EIA Loudspeaker Power Rating Full Range (ANSI/EIA RS426-A 1980). Both of these specifications use random-noise spectrum which mimic typical music and test the thermal and mechanical capabilities of the components. Electro-Voice will support relevant additional standards as and when they become available. Extreme, in-house power tests, which push the performance boundaries of the components, are also performed and passed to ensure years of trouble free service.

Specifically, the PIM-102 passes ANSI/EIA RS-426-A 1980 with the following values:

$$\begin{aligned} R_{SR} &= 6.0 \text{ ohms } (1.15 \times R_e) \\ P_{E(max)} &= 150 \text{ watts} \\ \text{Test voltage} &= 30 \text{ volts rms} \\ &= 60 \text{ volts peak (+6 dB)} \end{aligned}$$

ARCHITECTS' AND ENGINEERS' SPECIFICATIONS

The loudspeaker shall be a passive two-way system. Low frequencies shall be reproduced by an 8-ohm 254-mm (10-in.) woofer with an edge-wound flat-wire 63.5-mm (2.5-in.) voice coil capable of handling 150 watts long term per ANSI/EIA RS-426-A and with a sensitivity of 96 dB 1 watt/1 meter. High frequencies shall be reproduced by an 8-ohm compression driver with a 31.7-mm (1.25-in.) diaphragm and a 25-mm (1-in.) exit, capable of handling 20 watts long term per AES2-1984/ANSI S4.26-1984, coupled to a constant-directivity horn with a 90° x 40° coverage pattern and with a sensitivity of 112 dB. The high-frequency horn shall be rotatable 90° about its axis within the enclosure. The system shall reproduce frequencies from 85 to 18,000 Hz and have a nominal coverage pattern of 90° x 40°, with directivity control maintained down to 5,000 Hz. The recommended crossover frequency shall be 1,800 Hz. Maximum average sound pressure levels at 1 meter shall be 118 dB (low-frequency section) and 125 dB (high-frequency section), with short-term peaks 6 dB higher.

The enclosure shall be constructed of 7-ply void-free birch and finished in black textured paint. The enclosure shall have a trapezoidal footprint. Dimensions shall be 505 mm (19.9 in.) high, 375 mm (14.8 in.) wide at the front, 238 mm (9.4 in.) wide at the rear and 292 mm (11.5 in.) deep. Enclosure sides shall have a 15° draft angle. The enclosure shall have a suspension system approved by an independent structural engineer and consisting of three independent suspension points on the top and three on the bottom. Net weight shall be 18.2 kg (40.0 lb).

The loudspeaker system shall be the Electro-Voice PIM-102.

Note: the PIM-102 described above is the standard configuration. Acoustic and mechanical details will vary when different options are supplied.

UNIFORM LIMITED WARRANTY

Electro-Voice products are guaranteed against malfunction due to defects in materials or workmanship for a specified period, as noted in the individual product-line statement(s) below, or in the individual product data sheet or owner's manual, beginning with the date of original purchase. If such malfunction occurs during the specified period, the product will be repaired or replaced (at our option) without charge. The product will be returned to the customer prepaid. **Exclusions and Limitations:** The Limited Warranty does not apply to: (a) exterior finish or appearance; (b) certain specific items described in the individual product-line statement(s) below, or in the individual product data sheet or owner's manual; (c) malfunction resulting from use or operation of the product other than as specified in the product data sheet or owner's manual; (d) malfunction resulting from misuse or abuse of the product; or (e) malfunction occurring at any time after repairs have been made to the product by anyone other than Electro-Voice or any of its authorized service representatives. **Obtaining Warranty Service:** To obtain warranty service, a customer must deliver the product, prepaid, to Electro-Voice or any of its authorized service representatives together with proof of purchase of the product in the form of a bill of sale or receipted invoice. A list of authorized service representatives is available from Electro-Voice at 600 Cecil Street, Buchanan, MI 49107 (616/695-6831 or 800/234-6831). **Incidental and Consequential Damages Excluded:** Product repair or replacement and return to the customer are the only remedies provided to the customer. Electro-Voice shall not be liable for any incidental or consequential damages including, without limitation, injury to persons or property or loss of use. Some states do not allow the exclusion or limitation of incidental or consequential damages so the above limitation or exclusion may not apply to you. **Other Rights:** This warranty gives you specific legal rights, and you may also have other rights which vary from state to state.

Electro-Voice Speakers and Speaker Systems are guaranteed against malfunction due to defects in materials or workmanship for a period of five (5) years from the date of original purchase. The Limited Warranty does not apply to burned voice coils or malfunctions such as cone and/or coil damage resulting from improperly designed enclosures. Electro-Voice active electronics associated with the speaker systems are guaranteed for three (3) years from the date of original purchase. Additional details are included in the Uniform Limited Warranty statement.

Electro-Voice Flying Hardware (including enclosure-mounted hardware and rigging accessories) is guaranteed against malfunction due to defects in materials or workmanship for a period of one (1) year from the date of original purchase. Additional details are included in the Uniform Limited Warranty statement.

Electro-Voice Accessories are guaranteed against malfunction due to defects in materials or workmanship for a period of one (1) year from the date of original purchase. Additional details are included in the Uniform Limited Warranty statement.

Service and repair address for this product: Electro-Voice, Inc., 600 Cecil Street, Buchanan, Michigan 49107 (616/695-6831 or 800/234-6831).

Specifications subject to change without notice.



ELECTRO-VOICE a MARK IV company **600 Cecil Street, Buchanan, Michigan 49107**

MANUFACTURING PLANTS AT ■ BUCHANAN, MI ■ NEWPORT, TN ■ SEVIERVILLE, TN ■ OKLAHOMA CITY, OK ■ GANANOQUE, ONT.

© Electro-Voice, Inc. 1995 ■ Litho in U.S.A.

Part Number 532558 — 9534