

PIM-251

(standard configuration)

Dual 15-Inch, Vented Low-Frequency System for Permanent Installation

- Part of PI Matrix Series™—compact trapezoidal systems
- Components and physical characteristics optional, to meet many acoustic, architectural and mechanical requirements
- Extends response to 55 Hz (39 Hz in step-down mode)
- Integral suspension system for safe and easy installation

SPECIFICATIONS

Versions Available:

See PIM-251 ordering matrix (Figure 1)

Typical Axial Frequency Response (swept sine-wave input, anechoic environment, 4 volts at 1 kHz at 10 feet; see Figure 2):

55-1,800 Hz

Low-Frequency 3-dB-Down Point,

Normal:

55 Hz

Step-Down (with equalization):

39 Hz

Usable Low-Frequency Limit

(10-dB-down point),

Normal:

45 Hz

Step-Down (with equalization):

32 Hz

Recommended Crossover Frequency:

80-200 Hz

Crossover Slopes,

Recommended:

24 dB per octave

Minimum:

12 dB per octave

Long-Term Average Power-Handling

Capacity (per EIA RS-426-A 1980; see Power-Handling Test section),

1,200 watts

Sensitivity (far-field SPL referred to 1 meter, 1-watt input, anechoic environment, band-limited pink noise),

100-800 Hz:

101 dB

SPL at Full Power (far-field SPL at 1 watt/

1 meter referred to full power, anechoic environment, band-limited pink noise

100-800 Hz), Long-Term Average/Peak,

132 dB/138 dB

Impedance (drivers in parallel),

Nominal:

4 ohms

Minimum:

4.5 ohms

Half-Space Reference Efficiency:

8.6%

Beamwidth (angle included by 6-dB-down points on polar responses, indicated one-third-octave bands of pink noise; see Figure 3):

50 to 125 Hz Horizontal:

360°

400 to 800 Hz Vertical:

117°, ±15°

Directivity Factor R_0 (Q), Median over Indicated Range (see Figure 4):

50-125 Hz:

1.0

400-800 Hz:

10.8

Directivity Index D_i (10log₁₀R₀),

50-125 Hz:

0.0 dB

400-800 Hz:

10.3 dB

Distortion Response 1% Rated Input Power at 100 Hz (on axis at 1 meter from system),

Second Harmonic:

50 Hz: <1.0%

80 Hz: <1.0%

200 Hz: <1.0%

Third Harmonic,

50 Hz: <1.0%

80 Hz: <1.0%

200 Hz: <1.0%

FIGURE 1 — PIM-251 Ordering Matrix

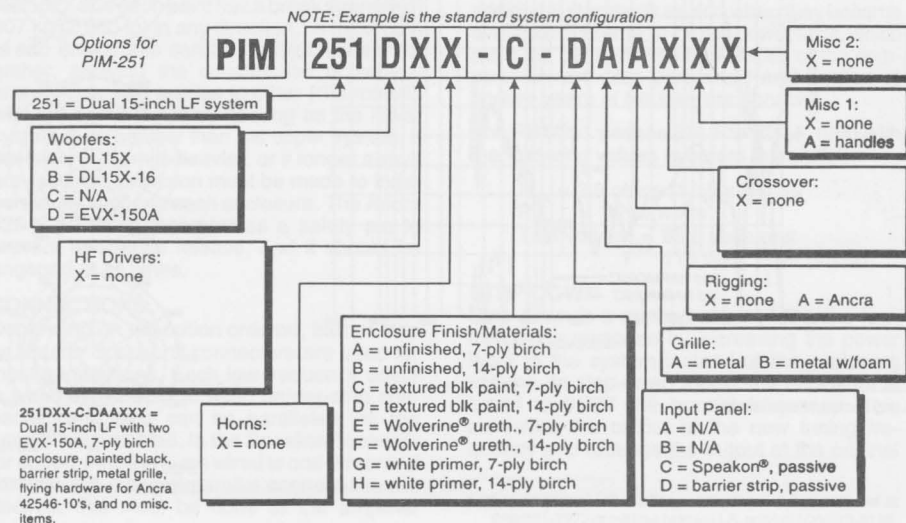

PIM-251 SPECIFICATION GRAPHICS

FIGURE 2 — PIM-251 Typical Axial Frequency Response (swept sine-wave input, anechoic environment, 4 volts at 10 feet normalized for 1 watt at 1 meter)

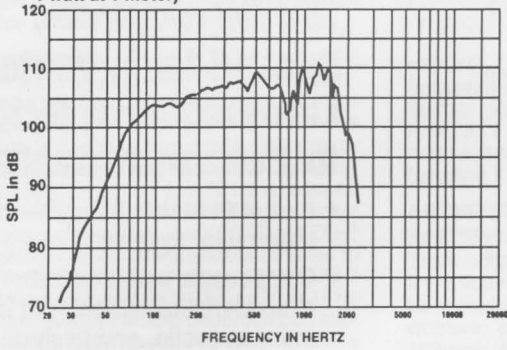

FIGURE 3 — PIM-251 Beamwidth vs. Frequency (one-third-octave bands of pink noise)

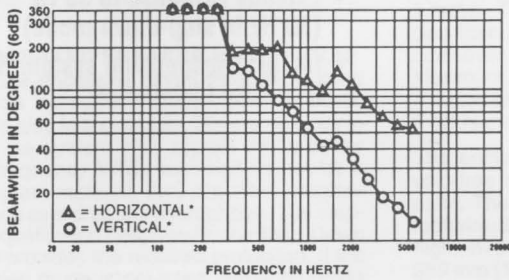

FIGURE 4 — PIM-251 Directivity Factor and Directivity Index vs. Frequency (one-third-octave bands of pink noise)

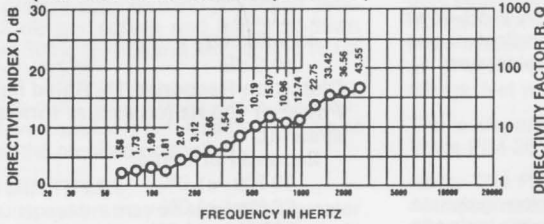

FIGURE 5 — PIM-251 Harmonic Distortion, 10% Rated Input Power at 100 Hz (on axis at 1 meter from system)

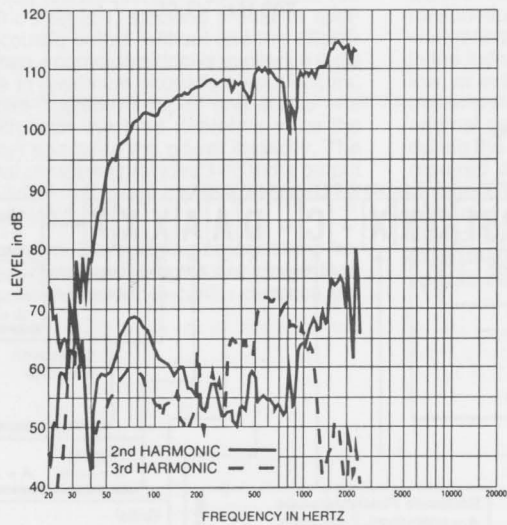

FIGURE 6 — PIM-251 Dimensions

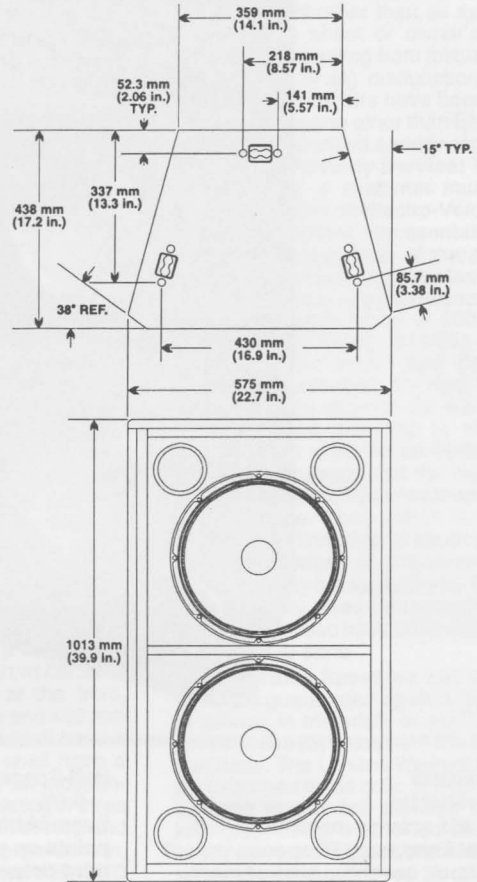
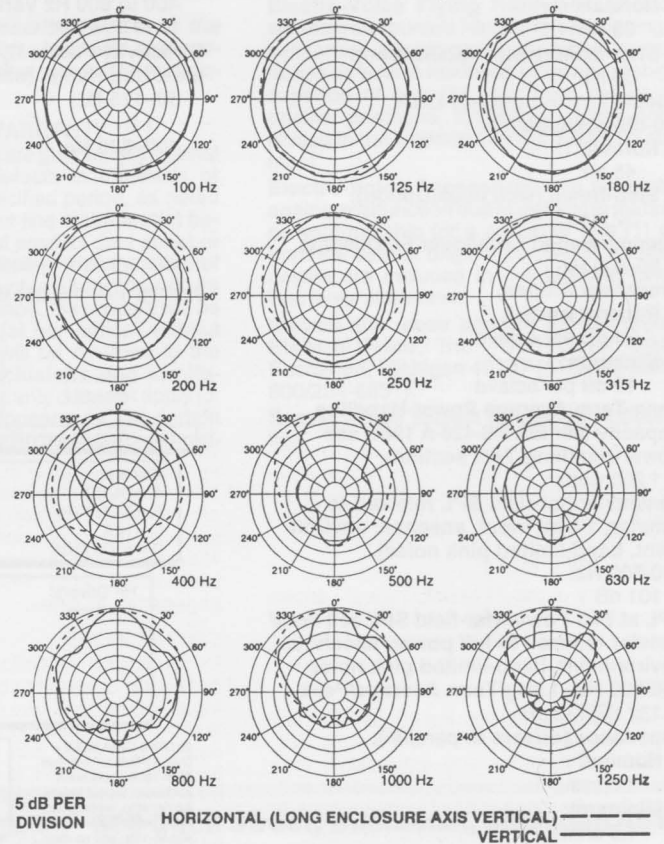

FIGURE 7 — PIM-251 Polar Responses, Selected to Typify Performance (one-third-octave bands of pink noise)



* Long enclosure axis vertical.

Distortion Response 10% Rated Input Power at 100 Hz (on axis at 1 meter from system; see Figure 5),

Second Harmonic,

50 Hz: 2.0%
80 Hz: 2.5%
200 Hz: <1.0%

Third Harmonic,

50 Hz: 1.1%
80 Hz: <1.0%
200 Hz: <1.0%

Transducer Complement,

Low Frequency:

Two EVX150A 381-mm (15-in.) woofers in a vented enclosure

Box Tuning Frequency,

Normal:

50 Hz

Step-Down:

35 Hz

Polarity:

A positive voltage applied to the positively marked input terminal produces a positive acoustic pressure at the front of the system

Input Connections:

#10 screw terminals on barrier strip; each driver can be individually accessed

Enclosure Materials and Color:

Textured black painted 7-ply void-free birch

Grille:

Black powder coated, vibration-resistant steel, removable

Suspension:

Integral three-point flying system (accepts Ankra 42546-10 single-stud tie-down cargo fitting; four fittings supplied with system; see Suspending PIM-251 Enclosures section)

Dimensions (see Figure 6),

Height:

1.01 m (39.9 in.)

Width at Front:

575 mm (22.7 in.)

Width at Rear:

359 mm (14.1 in.)

Depth:

438 mm (17.2 in.)

Side-Wall Draft Angle:

15°

Net Weight:

47.2 kg (104 lb)

Shipping Weight:

52.7 kg (116 lb)

DESCRIPTION AND APPLICATIONS

The Electro-Voice PIM-251 is a compact, trap-ezoidal low-frequency speaker system for permanent installation. Dual 15-inch woofers are mounted in an optimally vented enclosure. The PIM-251 is part of the PI Matrix Series™, a highly flexible group of full-range and low-frequency systems for applications where compact systems are appropriate. Many performing arts centers, clubs, auditoriums, sports facilities and houses of worship are candidates for the PI Matrix Series™.

The flexibility of the PI Matrix Series™ allows the designer to customize a system to both suit the acoustic environment and meet a wide variety of architectural and mechanical requirements.

PIM-251 options include low-frequency drivers, enclosure materials and finish, grilles, suspension hardware and input-panel connections, giving the sound contractor or consultant literally thousands of combinations to satisfy the overall system design criteria.

The PIM-251 standard configuration employs dual EVX-150A 381-mm (15-inch) long-throw, extended-reliability woofers. Operating between 55 and 1,800 Hz in a compact enclosure, the EVX-150A can handle very high levels of input power, producing high acoustic output with relatively low distortion.

The PIM-251 is equipped with a number of additional features to make operation and installation easy and secure. A proprietary structural extrusion is incorporated into the enclosure, providing safe and flexible suspension (see Suspending PIM-251 Enclosures section). Up to two enclosures of the same footprint can be suspended without additional support (as long as the lower system is not heavier than the upper system), so arrays can be created quickly and easily. The grille is composed of vibration-resistant steel for excellent driver protection, and an optional foam cover can be added for better protection when used outdoors. Besides the standard black-painted finish, the enclosure can also be ordered primed in white for painting with ordinary paints, unfinished for staining or with our special Wolverine® weather-resistant finish for outdoor applications. The PIM-251 drivers can be serviced from the front of the enclosure.

A complete listing of all system options is shown in Figure 1.

SUSPENDING PIM-251 ENCLOSURES

Suspending any object is potentially dangerous and should be attempted only by individuals who have a thorough knowledge of the techniques and regulations of hanging overhead. Electro-Voice strongly recommends that the PIM-251 be suspended taking into account all current national, federal, state and local regulations. It is the responsibility of the installer to ensure that the PIM-251 is safely installed in accordance with all such regulations. If the PIM-251 is suspended, Electro-Voice strongly recommends that the system be inspected at least once a year. If any sign of weakness or damage is detected, remedial action should be taken immediately.

The PI Matrix Series™ enclosures are suspended using the following approach, which has been approved by an independent structural engineer. Every enclosure incorporates six independent suspension points, three on the top and three on the bottom. A minimum of three points must be used at all times to suspend the enclosure. The suspension points, which "tie" the top and sides of the enclosure together, are made of structural aluminum. Each suspension point mates to an Ankra 42546-10 locking fitting (four are supplied with each enclosure ordered with this option, EV #20562), and each point has a break strength of 907 kg (2,000 lb) in any direction.¹ A maximum of two enclosures can be "daisy chained" together, allowing the construction of vertical arrays. This also applies to other PIM models with the same footprint, as long as the lower system is no heavier than the upper system. If the lower system is heavier, or if longer arrays are required, provision must be made to independently suspend each enclosure. The Ankra 42546-10 fitting incorporates a safety pin to prevent accidental release, and it should be engaged at all times.

CONNECTIONS

Depending on the option ordered, barrier strip or Neutrik Speakon® connectors are used for input connections. Each low-frequency driver is wired individually to each barrier-strip connector, and both can be paralleled via the jumper bar provided. In the Speakon® connector option, pins 1+/1- are wired to one driver and 2+/2- to the other. If parallel connections are desired, this must be done at the amplifier

terminals. In all cases, drivers are connected with the same polarity. A positive voltage applied to the positively marked terminal produces a positive acoustic pressure at the front of the system.

FREQUENCY RESPONSE

PIM-251 axial frequency response was measured in Electro-Voice's large anechoic chamber at a distance of 3.0 meters (10 feet) with swept sine-wave input. Figure 2 shows the typical system response, with a 4-volt drive, normalized for a 1-watt input and a 1-meter distance.

DIRECTIVITY

The directional characteristics of the PIM-251 were measured in Electro-Voice's large anechoic chamber, with a test signal of one-third-octave filtered pink noise at the frequencies indicated. A full spherical measurement system, which is fully compatible with Mark IV Audio's AcoustaCADD™ computer-aided design program, was used. All directional information was measured at 6.1 meters (20 feet).

Figure 7 illustrates the nominal horizontal and vertical polar responses, with the long system axis vertical.

Figure 3 illustrates the horizontal and vertical beamwidths. Beamwidth is the angle at which the horizontal and vertical polar responses have decreased in level by 6 dB when compared to the on-axis frequency response.

Figure 4 represents the total directivity of the PIM-251. The directivity factor, R_0 (Q), is the relative value, at a point, when compared to an ideal spherical response. The directivity index (D_0) is calculated by $D_0 = 10 \log_{10} R_0$.

SERVICE

In the unlikely event the PIM-251 requires service, the drivers can be replaced or serviced from the front. A service data sheet is available from Electro-Voice.

POWER-HANDLING TEST

Electro-Voice components and systems are manufactured to exacting standards, ensuring they will hold up, not only through the most rigorous of power tests, but also through continued use in arduous, real-life conditions. Two main test specifications are used: the AES Recommended Practice for Specification of Loudspeaker Components Used in Professional Audio and Sound Reinforcement (AES2-1984/ANSI S4.26-1984) and the EIA Loudspeaker Power Rating Full Range (EIA RS-426-A 1980). Both of these specifications use random-noise spectrum which mimics typical music and tests the thermal and mechanical capabilities of the components. Electro-Voice will support relevant additional standards as and when they become available. Extreme, in-house power tests, which push the performance boundaries of the components, are also performed and passed to ensure years of trouble-free service.

The PIM-251 passes EIA RS-426-A 1980 with the following values (woofers in parallel):

$R_{SR} = 2.9$ ohms ($1.15 \times R_E$)
 $P_{E(max)} = 1,200$ watts
Test voltage = 59.0 volts rms
118 volts peak (+6 dB)

STEP-DOWN

Step-down is a method of extending the low-frequency response by increasing the power input to the system instead of the enclosure volume. In step-down mode, the enclosure is tuned to 0.707 the normal frequency. This increases the output at the new tuning frequency and reduces the output at the original

1. For additional information, contact Ankra International at 606/371-7272 or toll free (within U.S. only) at 800/233-5138.

tuning frequency. This smoothly falling amplitude response can be equalized to obtain a new 3-dB-down point in the region of 0.7 that of the original. To obtain a similar response without step-down would require an enclosure with at least twice the volume.

Step-down tuning of the PIM-152 can be achieved by plugging one of its two vents, which lowers tuning from 50 to 35 Hz. A foam vent plug (part no. 71489) is available from the Electro-Voice Service Department. If an appropriate low-frequency boost-and-cut equalization is applied, the normal f_0 of 55 Hz is reduced to 39 Hz. It is suggested that the Electro-Voice Dx34 digital processor or the XEQ-2 or XEQ-3 analog active crossover/equalizers be used to provide the required equalization. (The XEQ-3 requires the optional EB29/35 EQ module.) The suggested equalization is an underdamped second-order high-pass filter tuned to 35 Hz with a Q of 2. This provides a boost of 6 dB at the tuning frequency and a 12-dB-per-octave roll-off below.

SUBPASSBAND SPEAKER PROTECTION

Below the enclosure tuning frequency, cone excursion increases rapidly. Since acoustic output is also falling rapidly, there is no utility in driving the system with signals much below tuning frequency. While such signals may be in the program material, they are often extraneous, such as a dropped microphone. The step-down equalization described in the Step-Down section provides the required protection. If the step-down mode is not used, the appropriate high-pass corner frequency is about 0.8 the box tuning frequency. Alternately, the EX-24, XEQ-2 and XEQ-3 analog crossover/equalizers can provide subpassband protection. Roll-off is 12 dB per octave and the 3-dB-down points are 30 Hz (EX-24 and XEQ-2) and 16 Hz or 32 Hz (XEQ-3).

Other high-pass filters are available and one-third octave equalizers can also be effective at providing the required protection.

USE IN MULTIPLES

Cone loudspeakers may be stacked for greater acoustic output and a narrower beamwidth. (It is assumed that all cones are operating in unison or "in phase.")

At relatively low frequencies, below about 150 Hz for the PIM-251, stacking produces additional acoustic output without altering dispersion. When a common signal is applied, a 6-dB increase in maximum acoustic output occurs. The cones "mutually couple" and act as one cone with twice the area (therefore twice the efficiency) and twice the power capacity. The additional cone area provides 3 dB more output and the additional power capacity accounts for the remaining 3 dB.

Specifically, mutual coupling occurs at the frequencies whose wavelengths are longer than one-quarter the center-to-center distance be-

tween the cones. The highest frequency at which mutual coupling occurs is calculated from the following equation:

$$f \cong \frac{3,000}{D_{MAX}}$$

where D_{MAX} is the distance in inches and f is the frequency in Hz. When D_{MAX} is greater than one-quarter wavelength, as would occur if two PIM-251's were widely spaced, the level increase tends to be limited to the 3-dB power-handling increase.

ARCHITECTS' AND ENGINEERS' SPECIFICATIONS

The loudspeaker shall be an optimally vented low-frequency system. Low frequencies shall be reproduced by dual 4-ohm, 381-mm (15-in.) woofers, each with an edge-wound flat-wire 102-mm (4-in.) voice coil capable of handling 600 watts long term per EIA RS-426-A and with an overall system sensitivity of 101 dB 1 watt/1 meter. The system shall reproduce frequencies from 55 to 1,800 Hz. The recommended crossover frequency shall be 80 to 200 Hz. Maximum average sound pressure levels at 1 meter shall be 132 dB with short-term peaks 6 dB higher.

The enclosure shall be constructed of 7-ply void-free birch and finished in black-textured paint. The enclosure shall have a trapezoidal footprint. Dimensions shall be 1.01 m (39.9 in.) high, 575 mm (22.6 in.) wide at the front, 359 mm (14.1 in.) wide at the rear and 439 mm (17.3 in.) deep. Enclosure sides shall have a 15° draft angle. The enclosure shall have a suspension system approved by an independent structural engineer and consisting of three independent suspension points on the top and three independent suspension on the bottom, all of which shall mate with Ancra 42546-10 fittings. Net weight shall be 47.2 kg (104 lb).

The loudspeaker system shall be the Electro-Voice PIM-251.

Note: The PIM-251 described above is the standard configuration. Acoustic and mechanical details will vary when different options are supplied.

UNIFORM LIMITED WARRANTY

Electro-Voice products are guaranteed against malfunction due to defects in materials or workmanship for a specified period, as noted in the individual product-line statement(s) below, or in the individual product data sheet or owner's manual, beginning with the date of original purchase. If such malfunction occurs during the specified period, the product will be repaired or replaced (at our option) without charge. The product will be returned to the customer prepaid. **Exclusions and Limitations:** The Limited Warranty does not apply to: (a) exterior finish or appearance; (b) certain specific items described in the individual prod-

uct-line statement(s) below, or in the individual product data sheet or owner's manual; (c) malfunction resulting from use or operation of the product other than as specified in the product data sheet or owner's manual; (d) malfunction resulting from misuse or abuse of the product; or (e) malfunction occurring at any time after repairs have been made to the product by anyone other than Electro-Voice or any of its authorized service representatives. **Obtaining Warranty Service:** To obtain warranty service, a customer must deliver the product, prepaid, to Electro-Voice or any of its authorized service representatives together with proof of purchase of the product in the form of a bill of sale or receipted invoice. A list of authorized service representatives is available from Electro-Voice at 600 Cecil Street, Buchanan, MI 49107 (616/695-6831 or 800/234-6831). **Incidental and Consequential Damages Excluded:** Product repair or replacement and return to the customer are the only remedies provided to the customer. Electro-Voice shall not be liable for any incidental or consequential damages including, without limitation, injury to persons or property or loss of use. Some states do not allow the exclusion or limitation of incidental or consequential damages so the above limitation or exclusion may not apply to you. **Other Rights:** This warranty gives you specific legal rights, and you may also have other rights which vary from state to state.

Electro-Voice Speakers and Speaker Systems are guaranteed against malfunction due to defects in materials or workmanship for a period of five (5) years from the date of original purchase. The Limited Warranty does not apply to burned voice coils or malfunctions such as cone and/or coil damage resulting from improperly designed enclosures. Electro-Voice active electronics associated with the speaker systems are guaranteed for three (3) years from the date of original purchase. Additional details are included in the Uniform Limited Warranty statement.

Electro-Voice Flying Hardware (including enclosure-mounted hardware and rigging accessories) is guaranteed against malfunction due to defects in materials or workmanship for a period of one (1) year from the date of original purchase. Additional details are included in the Uniform Limited Warranty statement.

Electro-Voice Accessories are guaranteed against malfunction due to defects in materials or workmanship for a period of one (1) year from the date of original purchase. Additional details are included in the Uniform Limited Warranty statement.

Service and repair address for this product: Electro-Voice, Inc., 600 Cecil Street, Buchanan, Michigan 49107 (616/695-6831 or 800/234-6831).

Specifications subject to change without notice.



ELECTRO-VOICE a MARK IV company 600 Cecil Street, Buchanan, Michigan 49107

MANUFACTURING PLANTS AT ■ BUCHANAN, MI ■ NEWPORT, TN ■ SEVIerville, TN ■ OKLAHOMA CITY, OK ■ GANANOQUE, ONT.
© Electro-Voice, Inc. 1995 ■ Litho in U.S.A. Part Number 532706 — 9532