

EVID Compact Sound Speaker System

EVID-C44, EVID-C2.1, EVID-40C, EVID-S44, EVID-S44W, EVID-2.1, EVID-2.1W, EVID-40S, and

EVID-40SW

en | Installation Manual



Table of contents

1	Safety	4
2	Welcome	6
2.1	System features	6
3	System overview	7
3.1	Packing lists	7
3.2	Product information	11
3.3	Dimensions	13
4	Installation	15
4.1	Ceiling mount speakers	15
4.1.1	Ceiling mount satellite speaker installation	15
4.1.2	Ceiling mount subwoofer installation	18
4.2	Surface mount speakers	22
4.2.1	Surface mount satellite speaker installation	22
4.2.2	Wall bracket range of motion	23
4.2.3	Surface mount subwoofer installation	23
4.2.4	Removing subwoofer from the wall	25
5	Wiring	26
5.1	Ceiling mount speakers	26
5.1.1	Wattage tap	26
5.1.2	70v/100v/4 ohm Mono	27
5.2	Surface mount speakers	28
5.2.1	Wattage tap	28
5.2.2	70v/100v/4 ohm Mono	29
5.2.3	8 ohm Stereo Surface Mount Subwoofer Only	30
6	Troubleshooting	31
7	Technical data	32
7.1	Ceiling mount speakers	32
7.1.1	Frequency response	32
7.2	Surface Mount Speakers	33
7.2.1	Frequency response	33
8	Notes	34

1 Safety



Warning!

Suspending any object is potentially dangerous and should only be attempted by individuals who have a thorough knowledge of the techniques and regulations of suspending objects overhead. Electro-Voice strongly recommends all loudspeakers be suspended taking into account all current national, federal, state, and local laws and regulations. It is the responsibility of the installer to ensure all loudspeakers are safely installed in accordance with all such requirements. When loudspeakers are suspended, Electro-Voice strongly recommends the system be inspected at least once per year or as laws and regulations require. If any sign of weakness or damage is detected, remedial action should be taken immediately. The user is responsible for making sure the wall, ceiling, or structure is capable of supporting all objects suspended overhead. Any hardware used to suspend a loudspeaker not associated with Electro-Voice is the responsibility of others.

Safety agency compliance

The EVID 2.1 and EVID 40S bracket systems have successfully passed EIA-636 at a safety factor of 8:1. The bracket systems are intended to support only the EVID 2.1 and EVID 40S respectively. Do not use either bracket system for any other purpose. Never set anything on or hang anything from the EVID 2.1 or EVID 40S enclosures when using the brackets.

Surface mount speakers

Redundant safety point

As an added safety measure, it is suggested the user install an extra suspension point back to the building structural supports. This redundant safety point should have as little slack as possible (less than 1-inch is preferable).

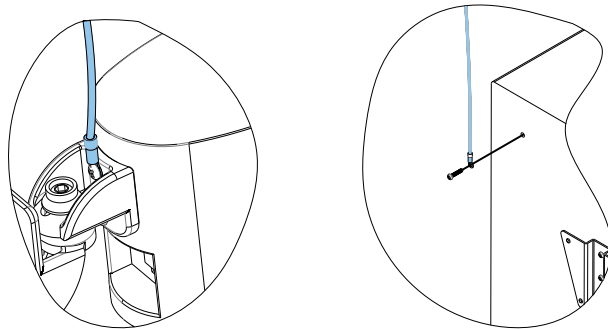

Figure 1.1: Surface mount satellite speaker (left) and surface mount subwoofer (right) with safety cable

Ceiling mount speakers



Caution!

The seismic tab (auxiliary support ring) is not intended for primary suspension of the loudspeaker. The seismic tab should only be used as a secondary safety point.



Caution!

Ceiling mount speaker's safety cable

The safety cable should be installed with a minimum of 3-inches (76.2 mm) of slack.

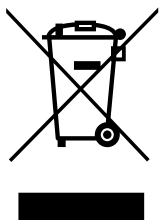
**Old electrical and electronic appliances**

Electrical or electronic devices that are no longer serviceable must be collected separately and sent for environmentally compatible recycling (in accordance with the European Waste Electrical and Electronic Equipment Directive).

To dispose of old electrical or electronic devices, you should use the return and collection systems put in place in the country concerned.

2 Welcome

Thank you for purchasing the EVID Compact Sound Speaker System. Read through this manual to familiarize yourself with the features, applications, and precautions before you use these products.

The EVID Compact Sound Speaker System is a very compact full-range loudspeaker ideal for applications requiring high-quality sound. Its shape flexibility and size make it nearly invisible for use in background/foreground music systems for restaurants, bars, patios, retail, and other applications. The system consists of a high performance 8-inch subwoofer module with a crossover network to support the included four (4) 2-inch satellite speakers. The system provides for easy signal connections at the subwoofer and can support either 4/8 ohm or 70/100v signal connections. Its high power handling allows the system to be used in a wide variety of environments and spaces to provide high quality background or foreground music.

2.1 System features

Common system features:

- Available as a complete pre-packaged systems in either Ceiling mount or Surface mount configurations.
- Components can be combined in any mix of 4 satellite speakers to a single subwoofer to meet décor or installation requirements.
- Supports up to 100 W, 70/100 V, and 8 ohm audio connections.

Ceiling version features:

- Quick-install design with captive mounting tabs to fit nearly any ceiling construction.
- Four-pin Phoenix connectors on ceiling satellite speakers support pass-thru wiring.
- UL 2043/1480 ratings allow for use in signaling applications and plenum air spaces.
- Ceiling cutout templates and all mounting accessories included.
- Available in white finish.

Surface-mount version features:

- Simplified mounting design for satellites—concept provides secure mounting while allowing for significant articulation and range of motion.
- Attractive subwoofer design with full-face grille—install it anywhere, no need to hide!
- Supports stereo operation with 8-ohm audio connections.
- Quick-mount slide-on wall bracket included.
- Available in black or white finishes.

3 System overview

3.1 Packing lists

Ceiling mount speakers

The EVID C44 speaker system package contains four (4) satellite speakers and one (1) subwoofer. When you open the box for the full system you will find three (3) main boxes inside; two (2) boxes for the satellite speakers and one (1) box for the subwoofer.

The major components included in one (1) box for the EVID C2.1 ceiling mount satellite speaker.

Item	Quantity	Description
A	2	EVID C2.1 ceiling mount satellite speakers
B	2	Grilles
C	2	C-ring supports
D	1	Cutout template
E	1	Engineering data sheet
F	2	Paint shields

Table 3.1: Ceiling Mount Satellite Speaker

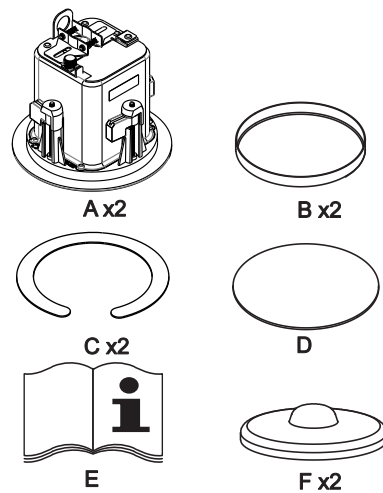

Figure 3.1: Components in kit

EVID Compact Sound Speaker System

The major components included in the box for the EVID 40C ceiling mount subwoofer:

Item	Quantity	Description
A	1	EVID 40C ceiling mount subwoofer
B	2	Tile rails
C	1	C-ring support
D	1	Grille
E	1	Installation manual
F	2	screws
G	1	Cutout template
H	1	Paint shield

Table 3.2: Ceiling Mount Subwoofer

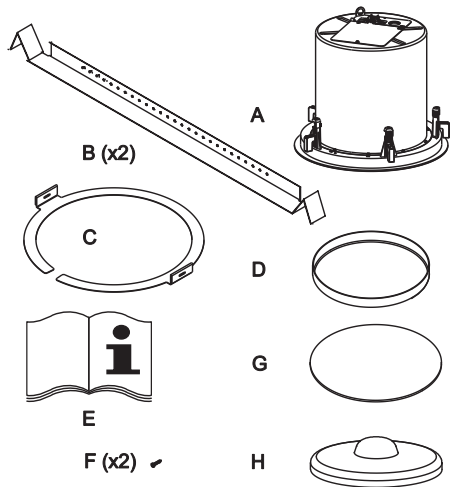

Figure 3.2: Components in kit

Surface mount speakers

The EVID S44 speaker system package contains four (4) satellite speakers and one (1) subwoofer. When you open the box for the full system you will find three (3) main boxes inside; two (2) boxes for the satellite speakers and one (1) box for the subwoofer.

The major components included in one (1) box for the EVID 2.1 surface mount satellite speaker.

Item	Quantity	Description
A	2	EVID 2.1 surface mount satellite speakers
B	2	Wall brackets
C	2	Speaker brackets
D	1	Engineering Data Sheet
E	2	M6 hex drive pan-head screws
F	4	M5 pan-head screws
G	2	Screw sockets
H	1	Hex wrench

Table 3.3: Surface Mount Satellite Speaker (1 box)

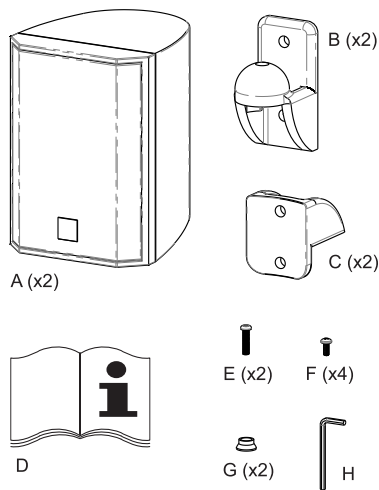

Figure 3.3: Components in kit

EVID Compact Sound Speaker System

The major components included in the box for the EVID 40S surface mount subwoofer:

Item	Quantity	Description
A	1	EVID 40S surface mount subwoofer
B	1	Wall bracket, assembled in box
C	1	Installation Manual
D	4	M6 hex drive pan-head screw
E	4	Rubber feet
F	1	Hex wrench

Table 3.4: Surface Mount Subwoofer

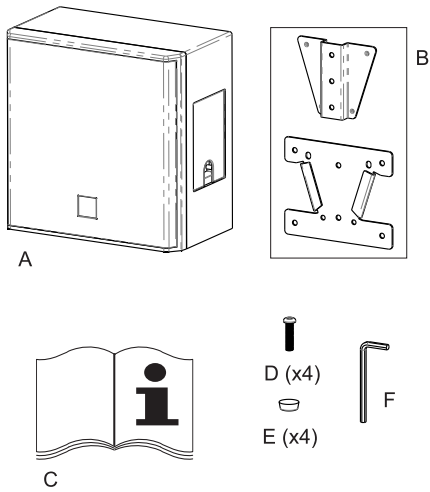

Figure 3.4: Components in kit

3.2

Product information

Ceiling mount speakers

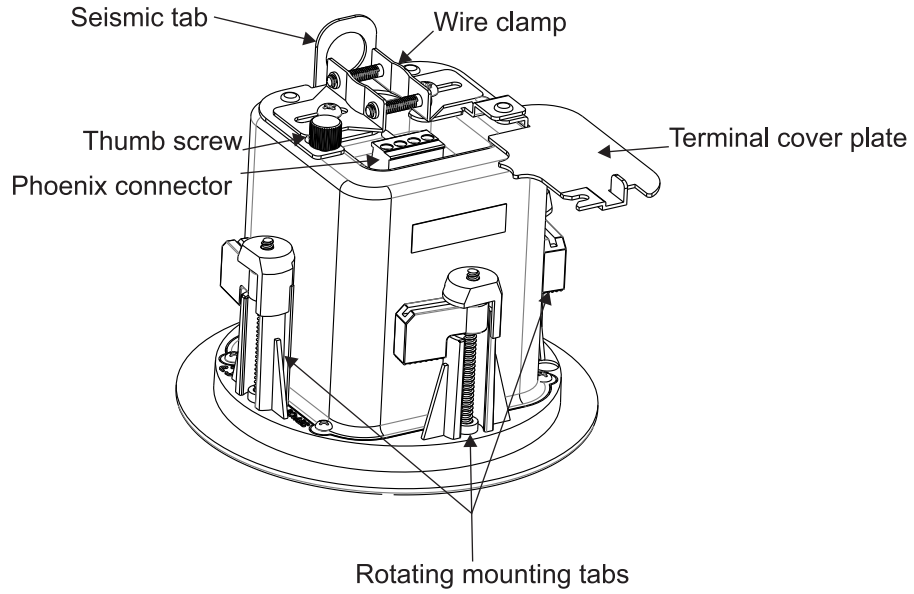

Figure 3.5: EVID C2.1 Product Information

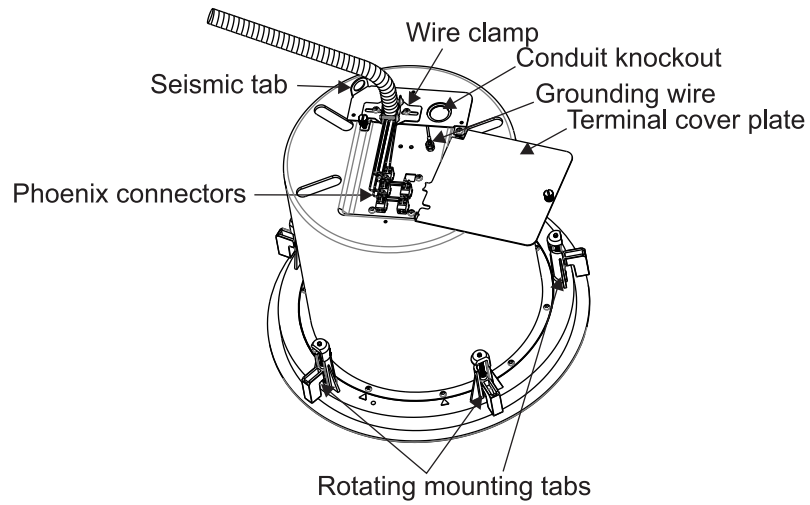

Figure 3.6: EVID 40C Product Information

EVID Compact Sound Speaker System

Surface mount speakers

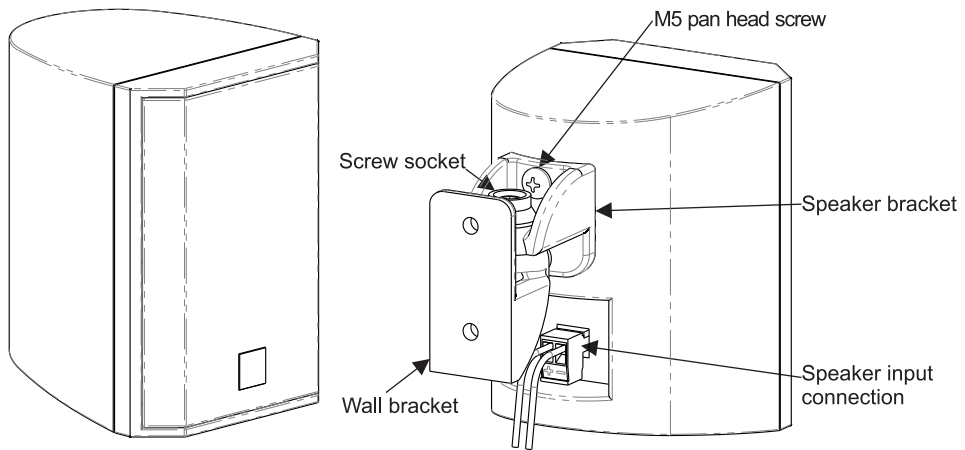

Figure 3.7: EVID 2.1 Product Information

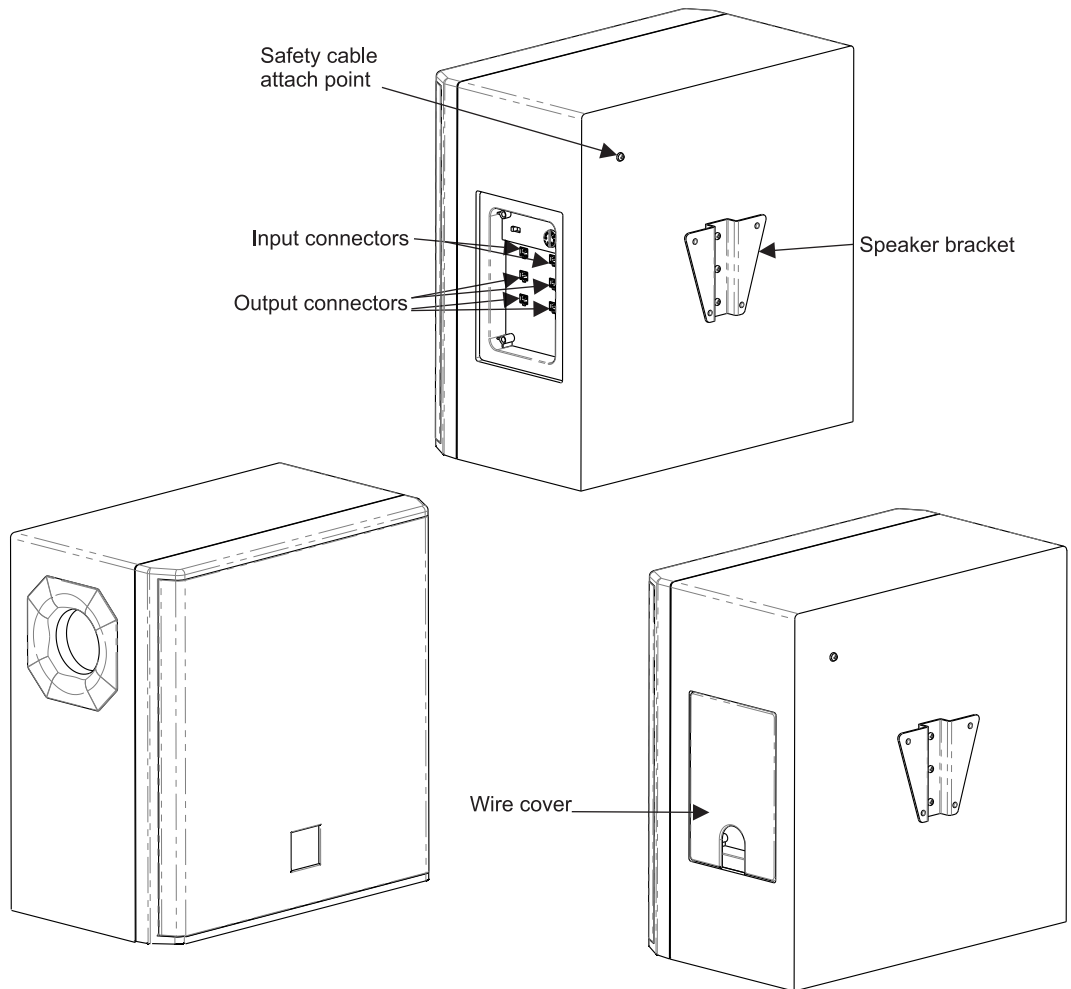

Figure 3.8: EVID 40S Product Information

3.3

Dimensions

Ceiling mount speakers

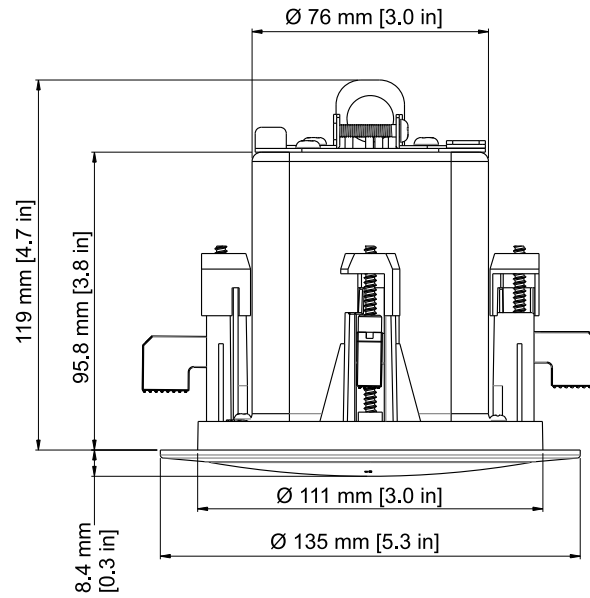

Figure 3.9: Dimensions EVID C2.1

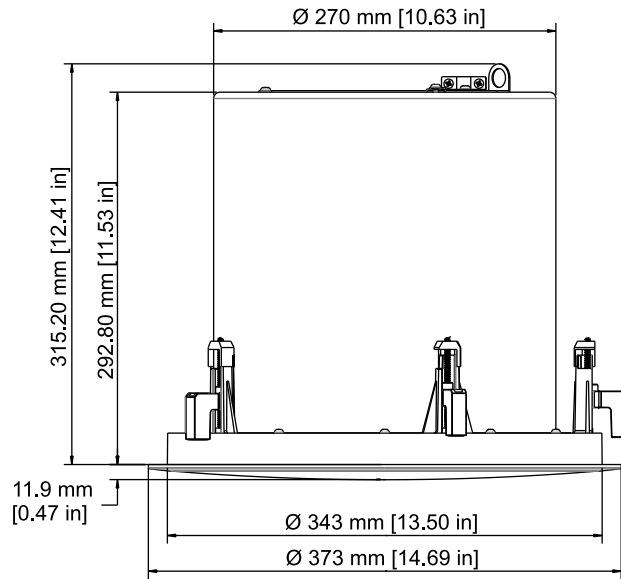

Figure 3.10: Dimensions EVID 40C

EVID Compact Sound Speaker System

Surface mount speakers

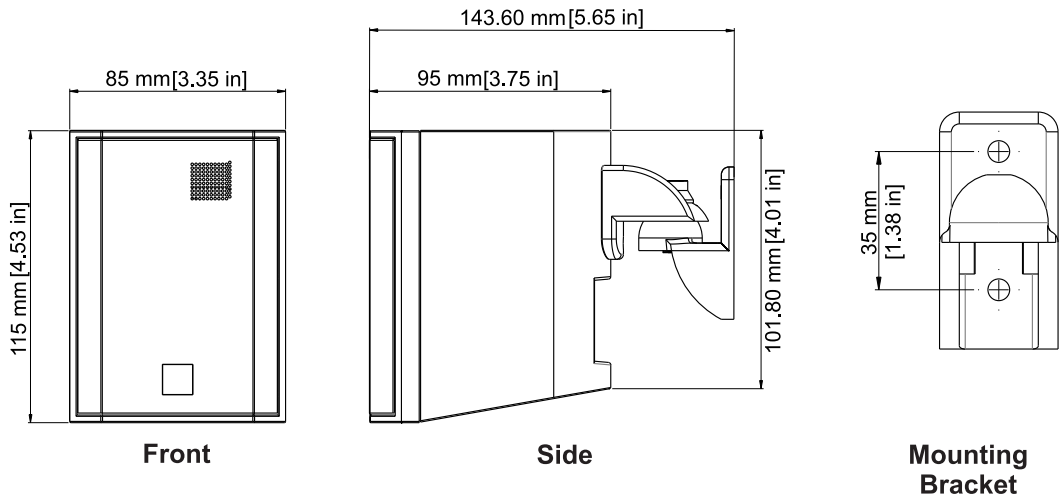

Figure 3.11: Dimensions EVID 2.1 and mounting bracket

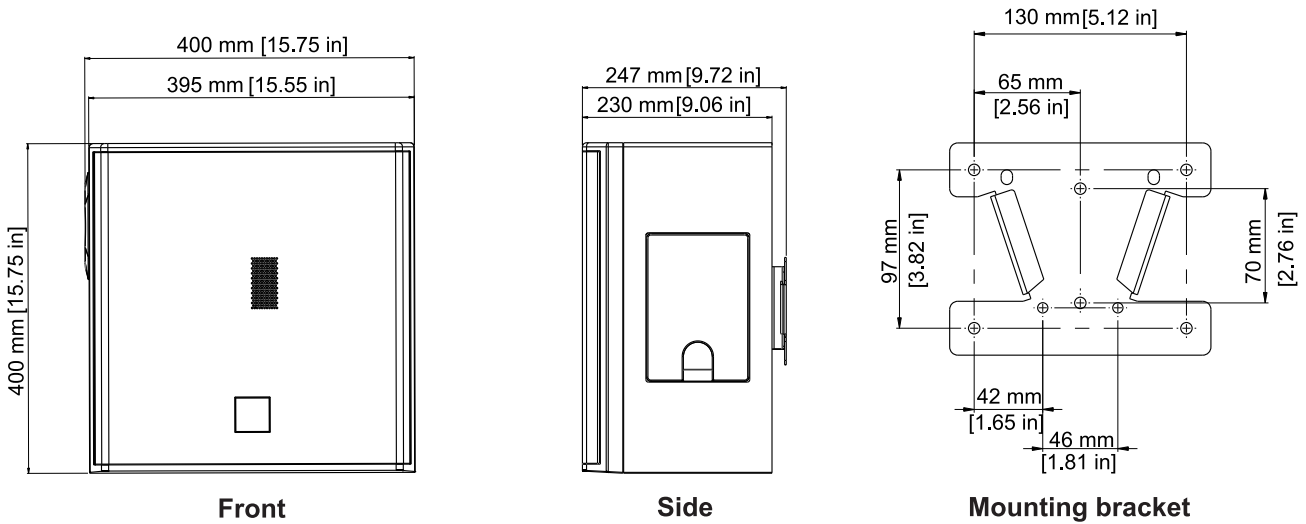

Figure 3.12: Dimensions EVID 40S and mounting bracket



Notice!

The mounting bracket dimension drawings are not to scale. Drawing sizes increased for readability.

4 Installation

4.1 Ceiling mount speakers

4.1.1 Ceiling mount satellite speaker installation

For safety, ensure the ceiling tiles or building structure supports more than the weight of the speaker. Consult an expert if you are unsure.

Installing a ceiling mount satellite speaker

To **install a ceiling mount satellite speaker**, do the following:

1. Trace the cutout **template**.

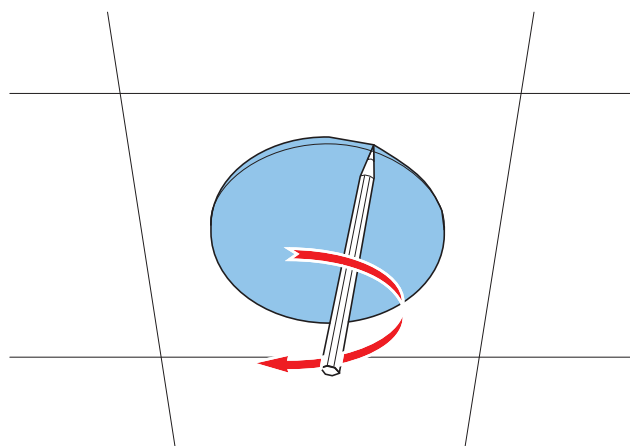

2. Cut the **hole**.

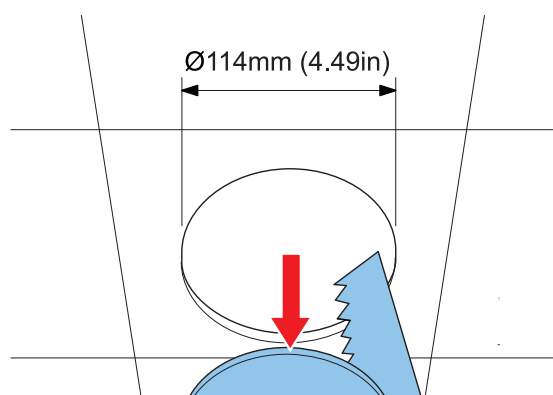

3. Attach the **C-Ring**.

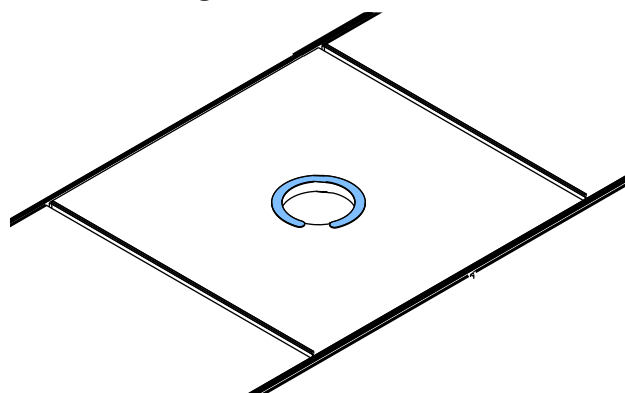

EVID Compact Sound Speaker System

4. Install the **wire conduit** into the speaker.

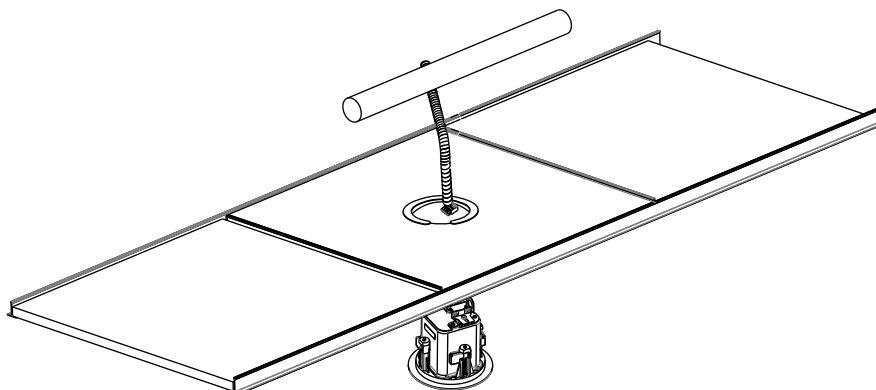

5. Install **wires** into the Phoenix connector.

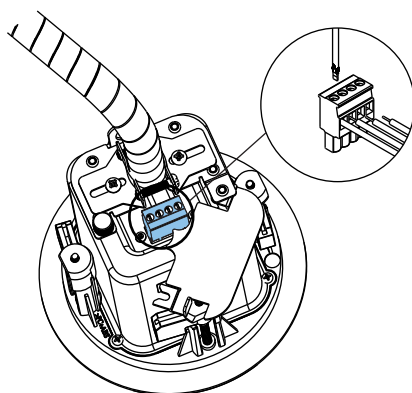

6. Tighten the **two (2) screws** to secure the conduit clamp.

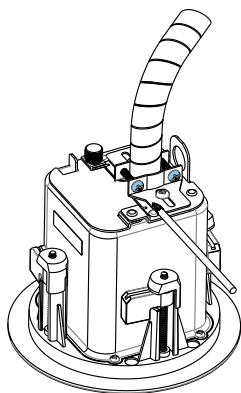

7. Attach the **safety cable**.
The safety cable should be installed with a minimum of a 3-inch (76.2 mm) slack.

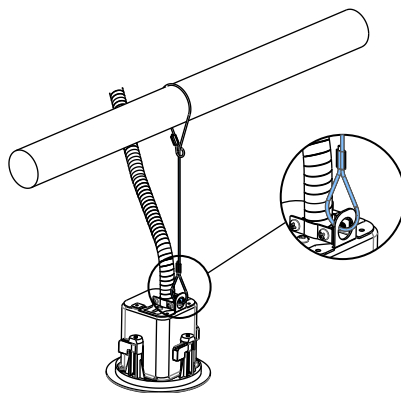

8. Push the **speaker** up into the ceiling.

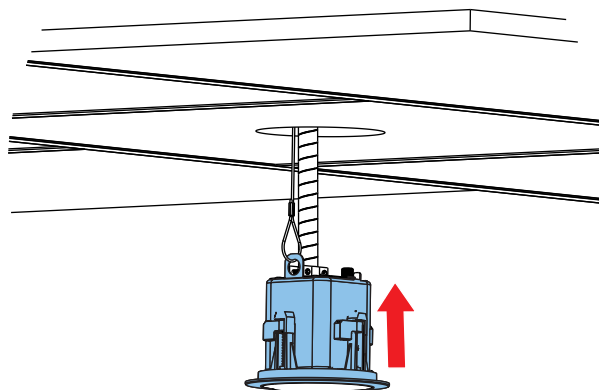

9. Tighten the **mounting tabs**.

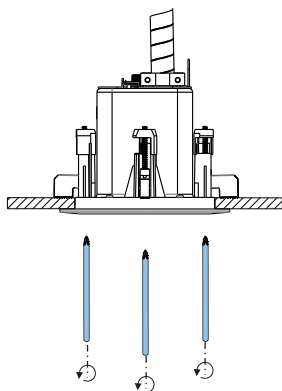

10. Attach the **grille**.

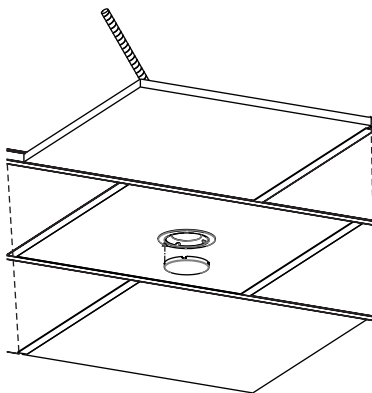

11. Installation complete.

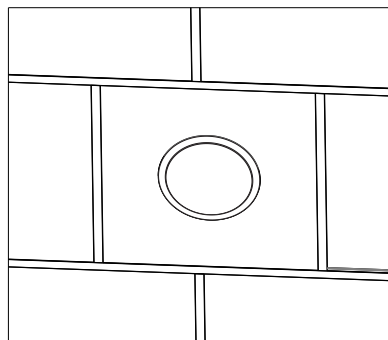

For more information, see Safety.

4.1.2 Ceiling mount subwoofer installation

For safety, ensure the ceiling tiles or building structure supports more than the weight of the speaker. Consult an expert if you are unsure.

Installing a ceiling mount subwoofer

To **install a ceiling mount subwoofer**, do the following:

1. Trace the cutout **template**.

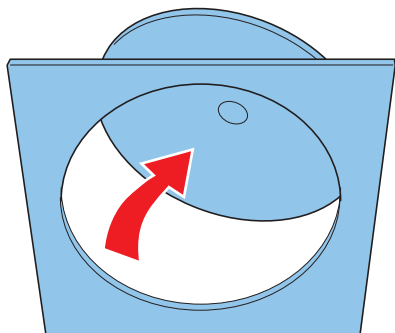

2. Cut the **hole**.

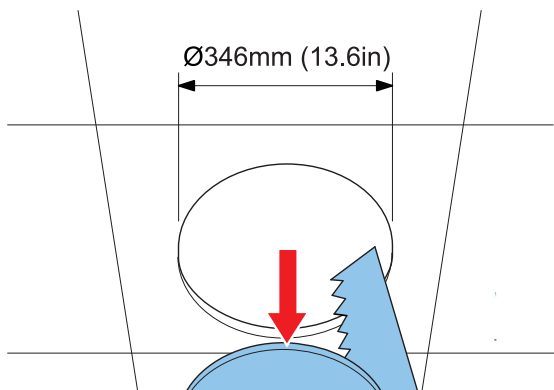

3. Secure rails to the **C-Ring**.

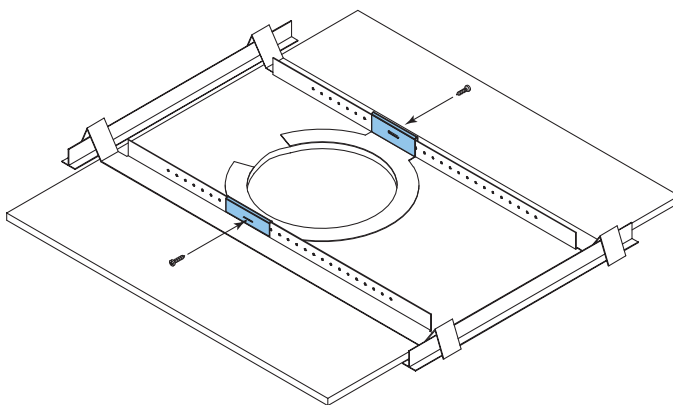

4. Attach the **safety cable** to the auxiliary support tab.

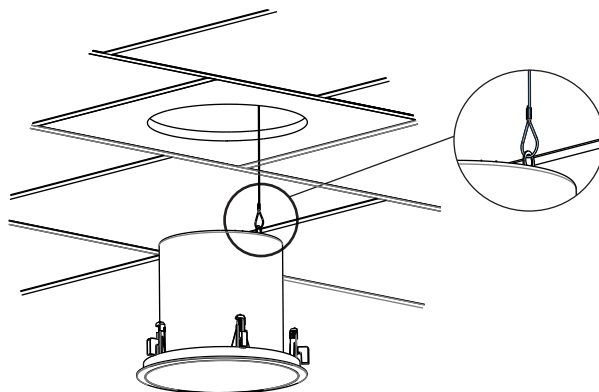

5. Route **wires** through the ceiling to the conduit clamp.

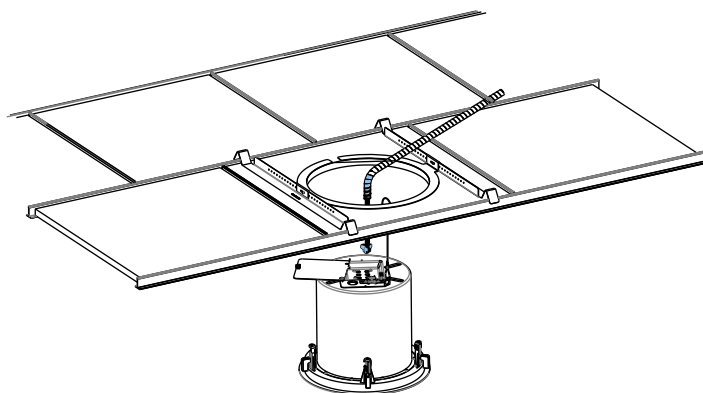

6. Connect the **wires** to the Phoenix connectors.

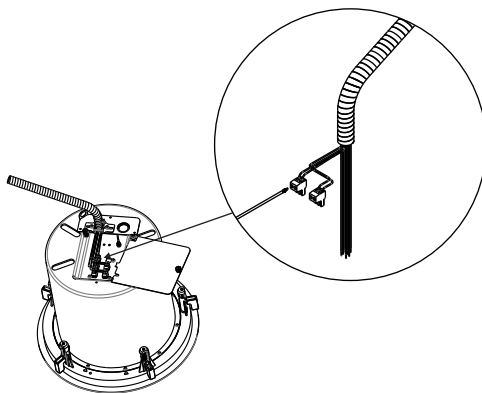

EVID Compact Sound Speaker System

7. Plug the **phoenix connector** into the socket.

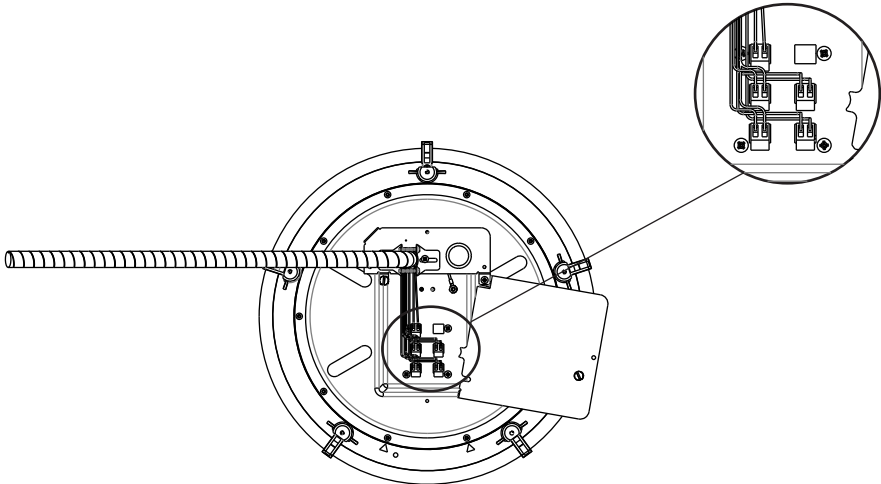

8. Tighten the **two (2) screws** to secure the conduit clamp.

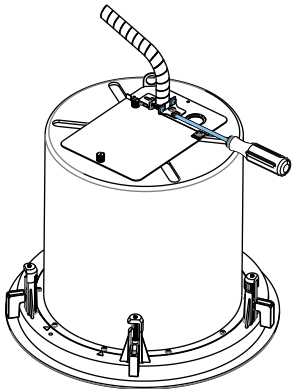

9. Push the **speaker** up into the ceiling.

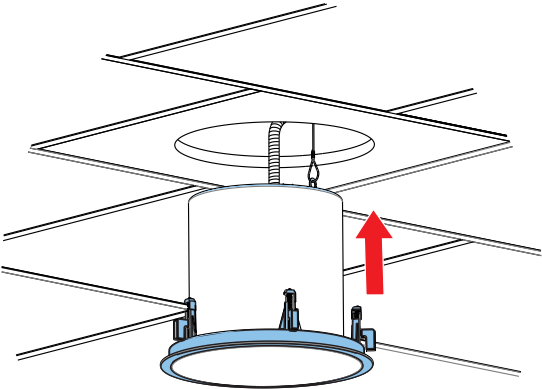

10. Tighten mounting **tabs**.

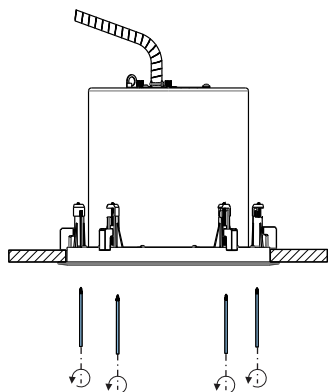

11. Attach the **grille**.

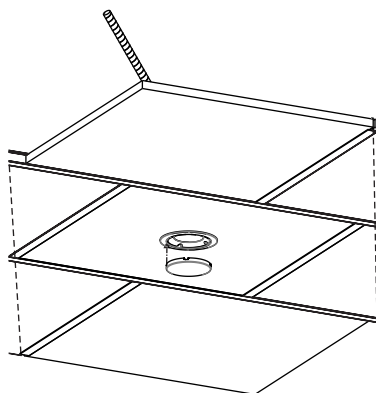

12. Attach the **auxiliary support line** to the structure.

The safety cable should be installed with a minimum of a 3-inch (76.2 mm) slack.

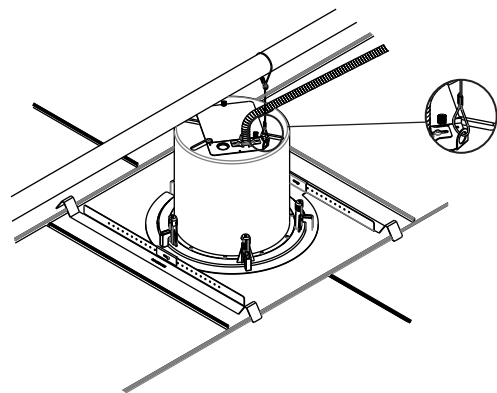

13. Installation complete.

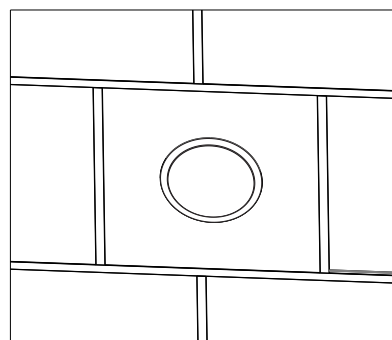

For more information, see Safety.

4.2 Surface mount speakers

4.2.1 Surface mount satellite speaker installation

For safety, ensure the mounting surface supports more than the weight of the speaker. Use only industry-accepted fasteners and mounting methods when mounting the wall bracket. Consult an expert if you are unsure.

Installing a surface mount satellite speaker

To **install a surface mount satellite speaker**, do the following:

1. Using a Phillips head screwdriver (not supplied), tighten **two (2) M5 pan-head screws (not supplied)** to attach the wall bracket to a secure mounting surface.

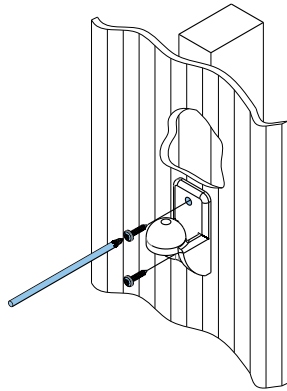

2. Using a Philips screwdriver, tighten **two (2) M5 pan-head screws (supplied)** to attach the speaker bracket to the rear of the cabinet.

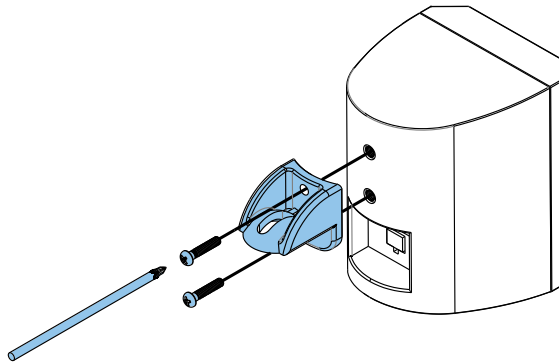

3. Place the **speaker bracket** onto the wall bracket.
4. Using the hex wrench (supplied), tighten the **M6 hex drive pan-head screw** to secure the speaker bracket to the wall bracket.

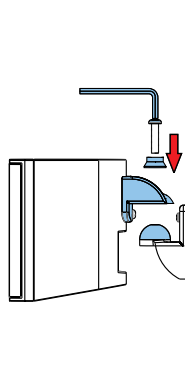

For more information, see *Safety*, page 4.

4.2.2 Wall bracket range of motion

The speaker can be adjusted from side to side or up and down.

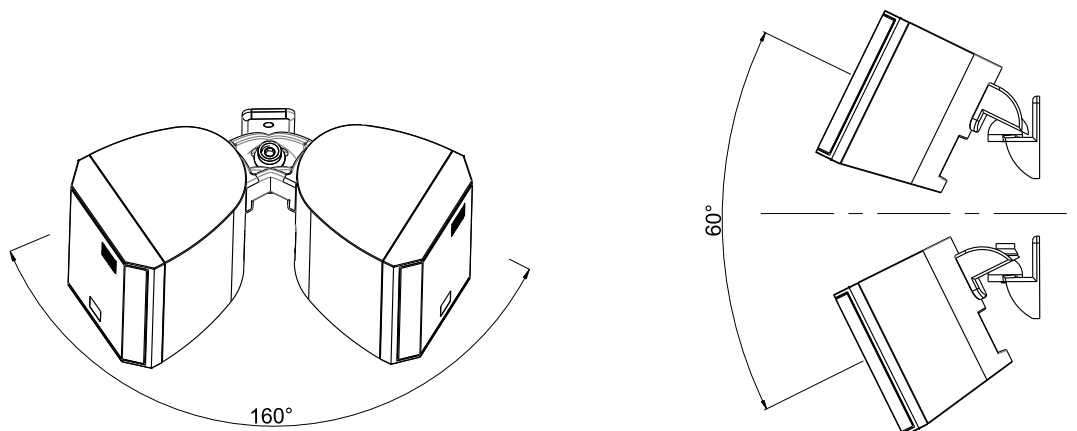

Figure 4.1: Horizontal range is 160° and the vertical range is 60°.

4.2.3 Surface mount subwoofer installation

For safety, ensure the mounting surface supports more than the weight of the speaker. Use only industry-accepted fasteners and mounting methods when mounting the wall bracket. Consult an expert if you are unsure.



Caution!

Only mount the wall bracket in the vertical V-shape position.
Do not mount the V-bracket or wall bracket side ways or upside down.

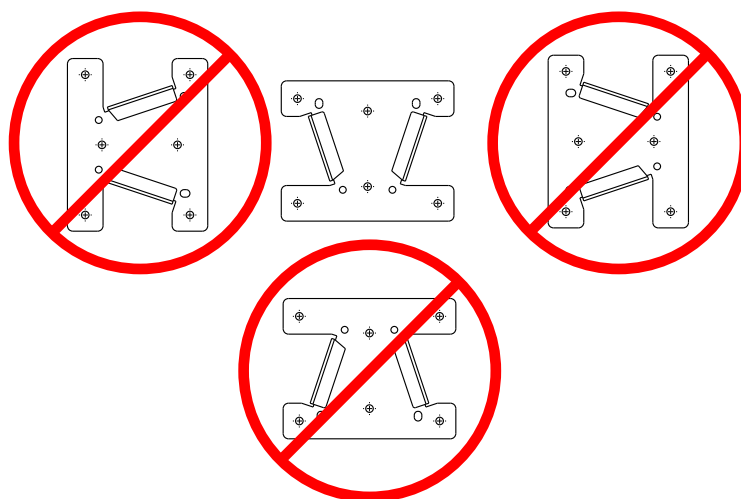

Figure 4.2: Wall bracket correct and incorrect mounting positions

EVID Compact Sound Speaker System



Caution!

Do not mount the surface mount subwoofer on the ceiling.
The surface mount subwoofer is not designed to mount on the ceiling.

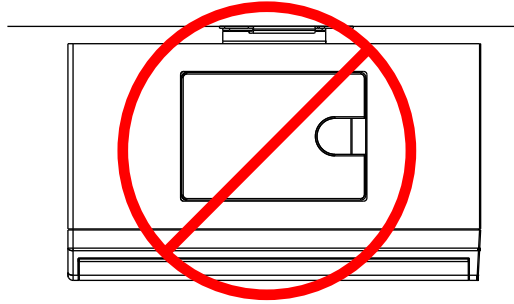

Installing a surface mount subwoofer

To **install a surface mount subwoofer**, do the following:

1. Using a Phillips head screwdriver (not supplied), tighten **six (6) M5 pan-head screws (not supplied)** to attach the wall bracket to a secure mounting surface.

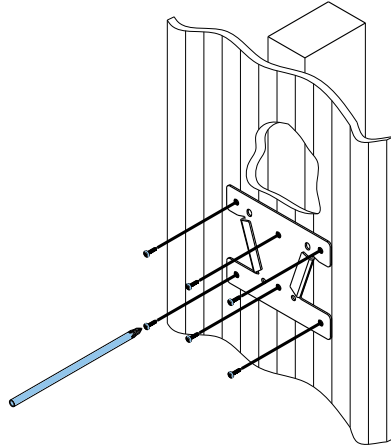

2. Using the hex wrench (supplied), tighten the **three (3) M6 hex drive pan head screws** to attach the V-bracket.

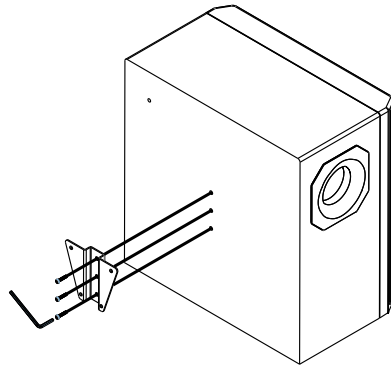

3. Slide the **V-bracket** into the wall bracket.
The locking detents engage.

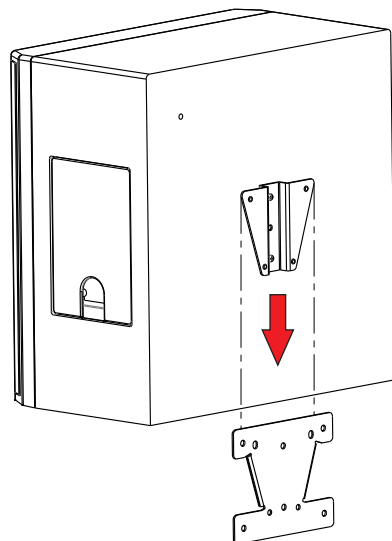

For more information see, *Safety*, page 4.

4.2.4 Removing subwoofer from the wall

To **remove the subwoofer from the wall**, do the following:

1. Pull the **subwoofer** slightly out from the wall.

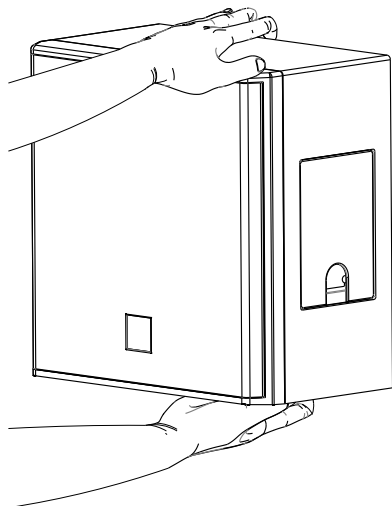

2. Lift the **subwoofer** up.
The locking detents disengage.

5 Wiring

5.1 Ceiling mount speakers

5.1.1 Wattage tap

Prior to wiring your system, select the mode of operation (100V/70V/4 ohm) by selecting power taps using the rotary switch on the subwoofer input panel. The power taps are 100 W, 50 W, 25 W, and 12.5 W at 70V or 100 W, 50 W, and 25 W 100V. The power selector switch is located on the baffle behind the grille.

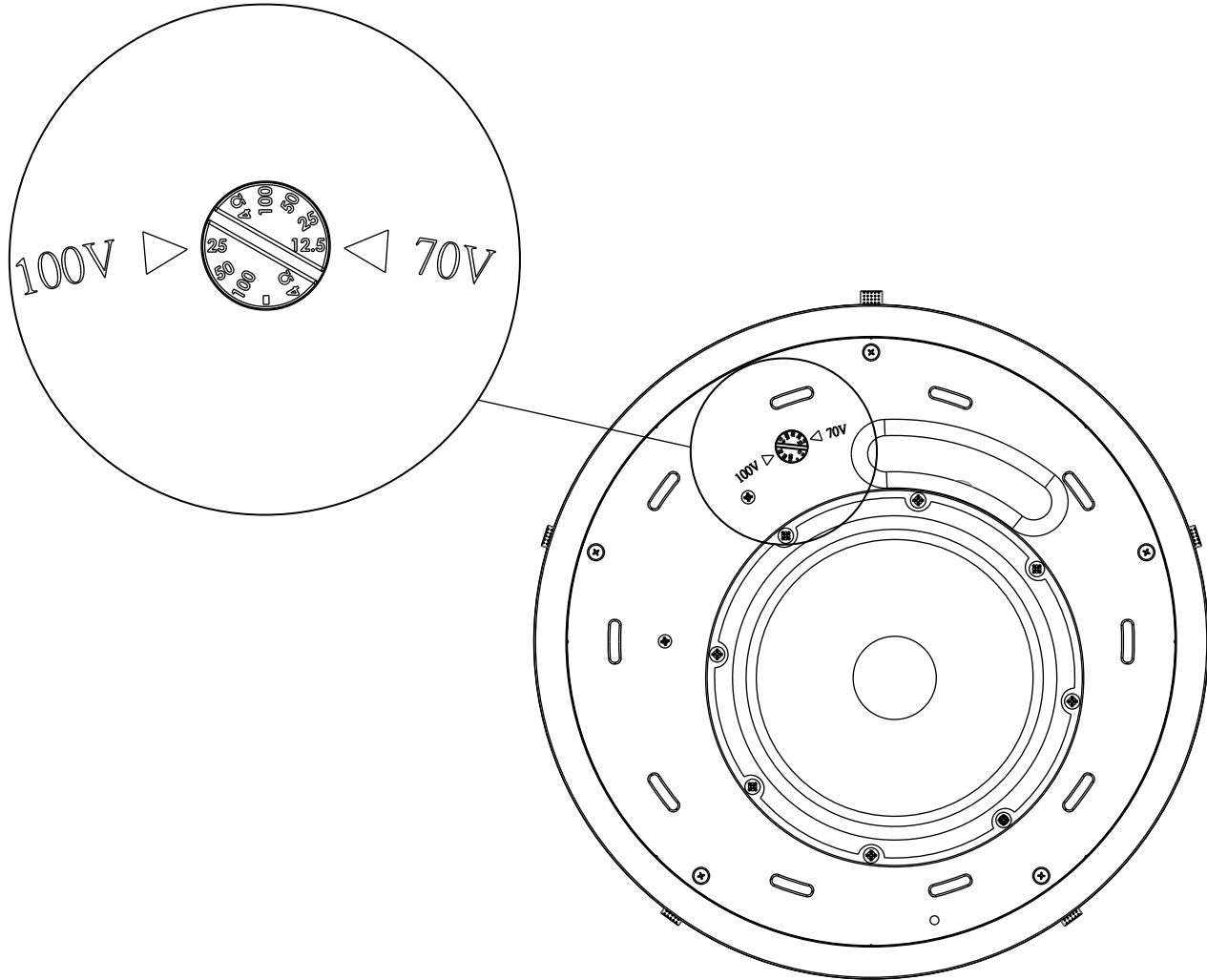
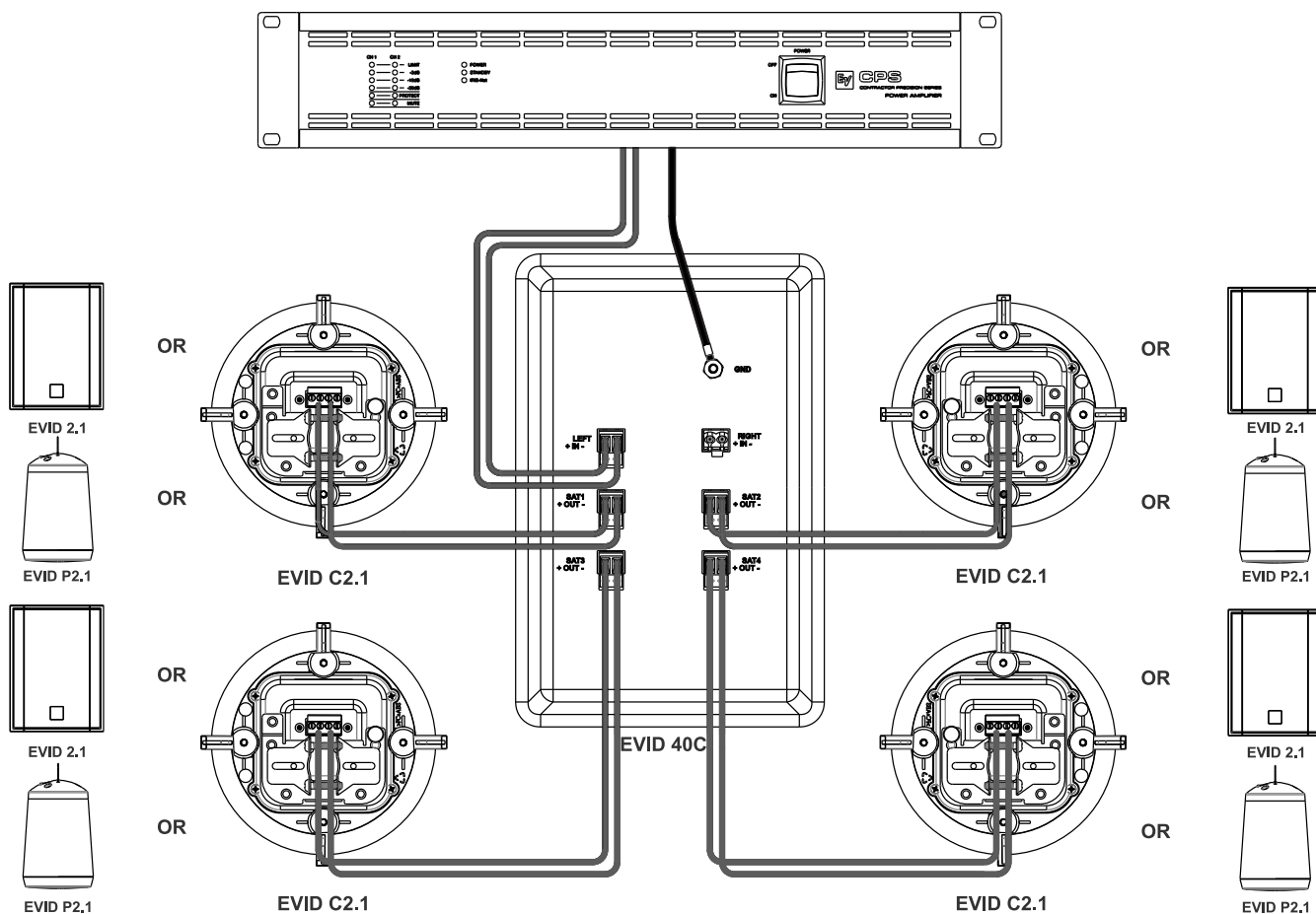

Figure 5.1: EVID 40C Wattage Tap

5.1.2 70v/100v/4 ohm Mono

The amplifier and EVID Compact Sound Speaker System product family is wired for MONO mode. It is highly advisable to support the unit while these connections are being made. Connect all wires to the speaker at the back terminal plate observing proper polarity of the connections. After all connections are made, test the complete system operation.



Notice!



Any combination of four satellites (surface mount, ceiling or pendant speakers) is allowed.

The system is designed for operation with only four (4) satellite speakers. Operation with less than four (4) satellite speakers is not recommended.

5.2 Surface mount speakers

5.2.1 Wattage tap

Prior to wiring your system, select the mode of operation (100V/70V/4 ohm or 8 ohm stereo) by setting the slider switch to the appropriate setting. Select taps using the rotary switch on the subwoofer input panel. The power taps are 100 W, 50 W, 25 W, and 12.5 W at 70.7V and 100V, as well as a 4 ohm transformer bypass setting. A guide on the input panel shows which switch positions to use for the power settings at 70V and 100V.

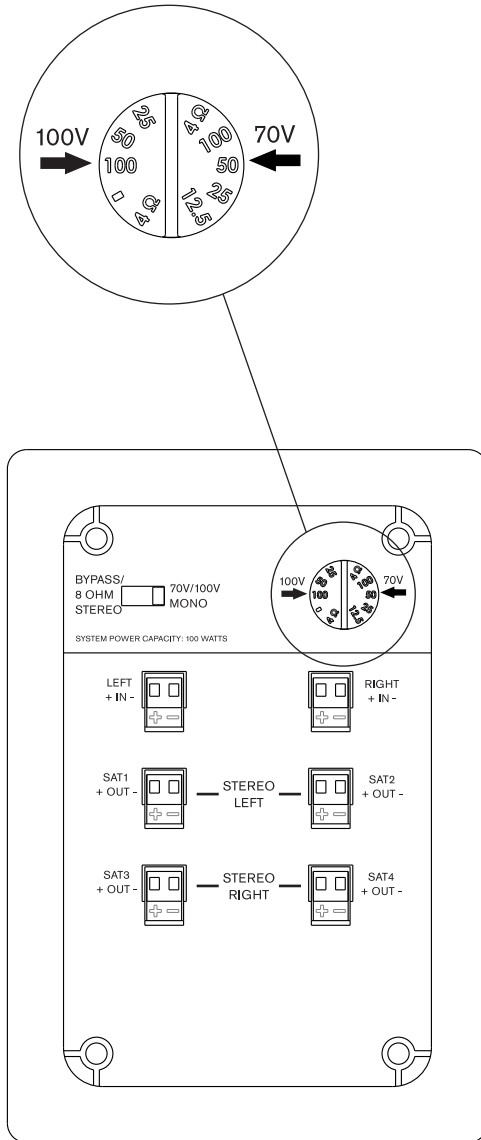
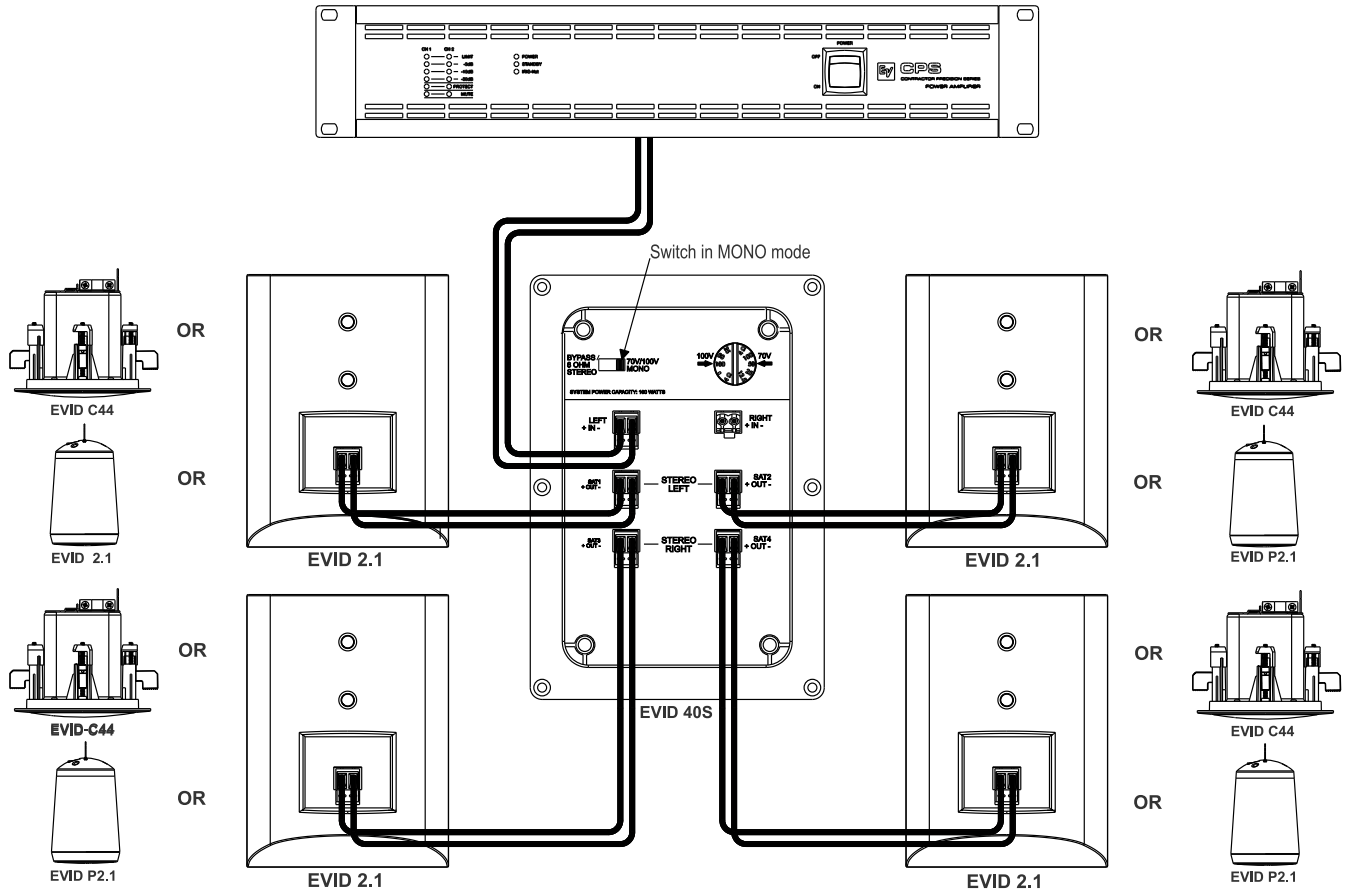

Figure 5.2: EVID 40S wattage tap

5.2.2 70v/100v/4 ohm Mono

The amplifier and EVID Compact Sound Speaker System is wired for MONO mode. It is highly advisable to support the unit while these connections are being made. Connect all wires to the speaker at the back terminal plate observing proper polarity of the connections. After all connections are made test the complete system operation.



Notice!



Any combination of four satellites (surface mount, ceiling or pendant speakers) is allowed.

The system is designed for operation with only four (4) satellite speakers. Operation with less than four (4) satellite speakers is not recommended.

EVID Compact Sound Speaker System

5.2.3

8 ohm Stereo Surface Mount Subwoofer Only

The amplifier and EVID Compact Sound Speaker System is wired for STEREO mode. It is highly advisable to support the unit while these connections are being made. Connect all wires to the speaker at the back terminal plate observing proper polarity of the connections after all connections are made test the complete system operation.

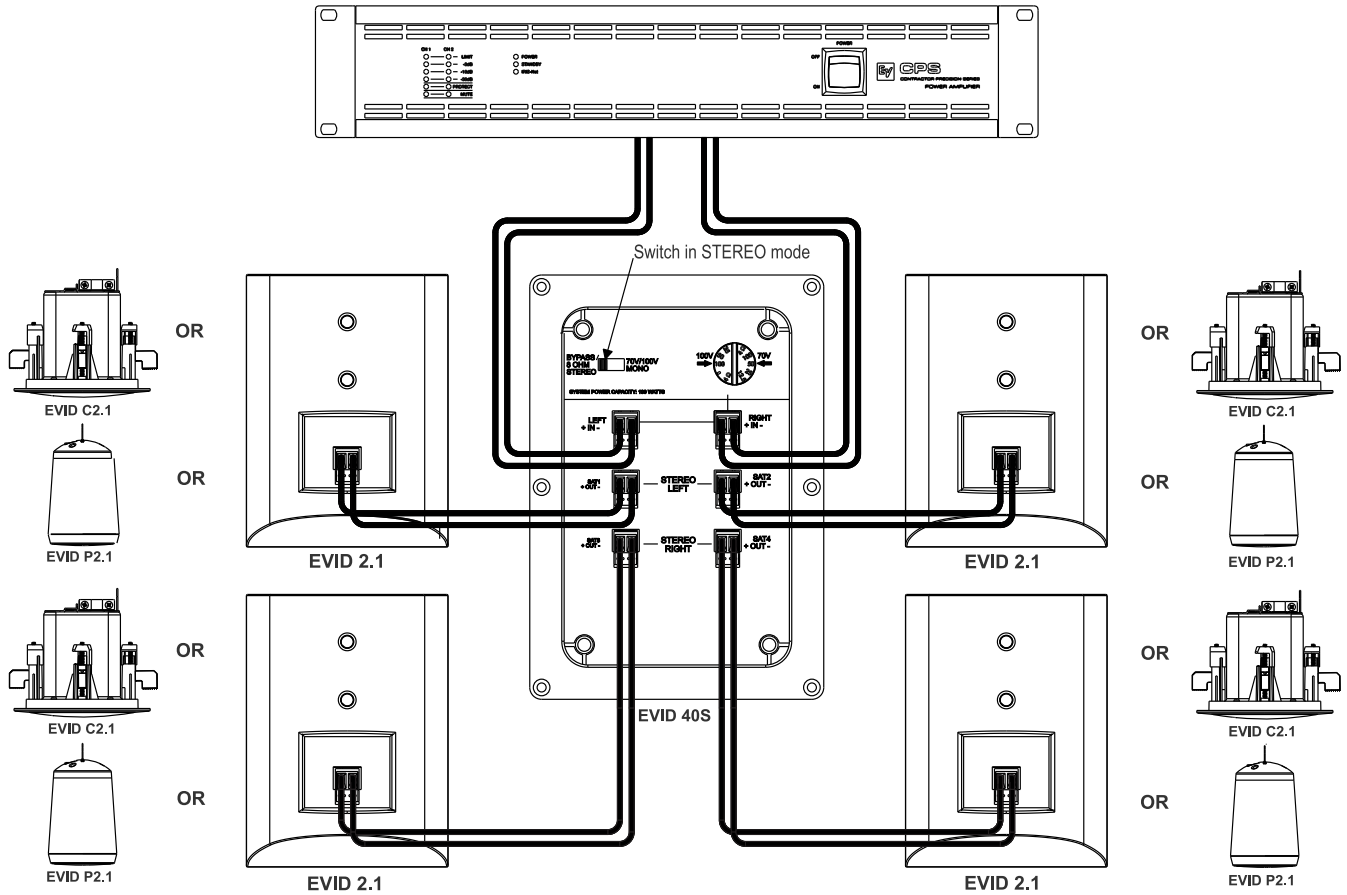

Notice!



Any combination of four satellites (surface mount, ceiling or pendant speakers) is allowed.

The system is designed for operation with only four (4) satellite speakers. Operation with less than four (4) satellite speakers is not recommended.

Notice!



A standard low impedance (4/8 ohm) amplifier source is required when operating the unit in STEREO mode.

100/70v operation is not supported in STEREO mode.

6 Troubleshooting

Problem	Possible Causes	Action
No Sound	Amplifier	Connect a known working test speaker to the amplifier outputs. If there is no sound, check all electronics are on, the signal routing is correct, the source is active; the volume is turned up, and so on. Correct/Repair/Replace as necessary. If there is sound, the problem is in the wiring.
	Wiring	Verify you have connected the correct wire pairs to the amplifier. Play something at low level through the amplifier (for example, from a CD player or tuner). Connect the test speaker in parallel with the malfunctioning line. If the sound has gone or is very weak, the line has a short in it (possibly a severe scrape, pinch, or staple puncture). If the sound level is normal the wire is open (possibly a cut wire or missed connection). Using the test speaker, move down the line and test each connection/junction until you find the problem and correct it. Observe proper polarity.
		Verify you have the inputs and outputs connected to the correct wires. If the subwoofer input panel is not correctly wired, there will be little or no sound. Observe proper polarity.
Poor Low-Frequency Response	Speakers Wired Out-of-Polarity	When two (2) speakers are connected out of polarity (out of phase), the low frequencies will cancel each other acoustically. Carefully observe the wire markings or tracers on your speaker wires. Verify the amplifier (+) terminal is connected to the red speaker terminals and the amplifier (-) terminal is connected to the black speaker terminals.
	Improperly Wired Subwoofer Panel	Using a test speaker as described above, verify all amplifier and speaker wires are connected to their proper terminals with the correct polarity. Reversing just one (1) set of amplifier wires can cut out all bass output from the subwoofer.
Intermittent Output such as, Crackling or Distortion	Faulty Connection	Check all connections at amplifier and speakers to ensure they are clean and tight. If the problem persists, it may be in the amplifier or wiring. See other actions above.
Constant Noise such as Buzzing, Hissing, Humming	Defective Amplifier or other Electronic Device	If the noise is present but no program material is playing, the likely cause is the signal chain in the electronics. Evaluate each component as necessary to isolate the problem.
	Poor System Grounding or Ground Loop	Check and correct the system grounding, as required.

If these suggestions do not solve your problem, contact your nearest Electro-Voice dealer or Electro-Voice distributor.

7 Technical data

7.1 Ceiling mount speakers

EVID C2.1 and EVID 40C

	EVID C2.1	EVID 40C
Frequency Response (-10 dB):	180 Hz - 20 kHz ¹	45 Hz - 300 Hz ¹
Power Handling:	30 W ²	200 W ²
Sensitivity:	84 dB ¹	88 dB ¹
Impedance:	16 ohms	mono 4 ohm
Maximum SPL:	102 dB	114 dB
Voice Coverage (H x V):	150° x 150° ³	Omnidirectional
Music Program Coverage (H x V):	100° x 100° ⁴	Omnidirectional
Transducer:	50 mm (1.97 in)	200 mm (7.87 in)
Connectors:	Phoenix (4-pin)	Phoenix (2-pin)
Enclosure:	Steel & ABS (fire rated)	Steel & ABS (fire rated)
Transformer Taps:	N/A	100 W, 50 W, 25 W, 12.5W
Dimensions (H x Dia):	119 mm x 135 mm (4.7 in x 5.3 in)	316 mm x 373 mm (12.44 in x 14.69 in)
Cutout Size:	114 mm (4.49 in)	346 mm (13.6 in)
Net Weight: (each)	0.82 kg (1.8 lb)	9.52 kg (21 lb)
Shipping Weight: (pair)	1 sub and 4 satellites: 19.05 kg (42 lb)	
Included Accessories:	C-Ring	C-Ring, Tile Rails

1. Half space.
2. Long Term Program Rating, 3 dB greater than continuous noise pink noise rating.
3. Average 1 kHz – 4 kHz.
4. Average 1 kHz – 8 kHz.

7.1.1 Frequency response

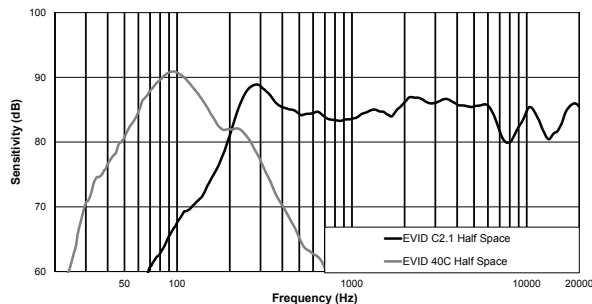

7.2 Surface Mount Speakers

EVID 2.1 and EVID 40S

	EVID 2.1	EVID 40S
Frequency Response (-10 dB):	180 Hz - 20 kHz ¹	42 Hz - 300 Hz ¹
Power Handling:	30 W ²	200 W ²
Sensitivity:	84 dB ¹	88 dB ¹
Impedance:	16 ohms	Dual 8 ohm / mono 4 ohm
Maximum SPL:	102 dB ¹	114 dB ¹
Voice Coverage (H x V):	150° x 150° ³	Omnidirectional
Music Program Coverage (H x V):	100° x 100° ⁴	Omnidirectional
Transducer:	50 mm (1.97 in)	200 mm (7.87 in)
Bracket Adjustment Range (H x V):	160° x 60°	Fixed
Connectors:	Phoenix (2-pin)	Phoenix (2-pin)
Enclosure:	ABS (fire rated)	Wood (MDF)
Transformer Taps:	NA	100 W, 50 W, 25 W, 12.5 W
Dimensions (H x W x D):	115 mm x 85 mm x 95 mm (4.53 in x 3.35 in x 3.75 in)	400 mm x 400 mm x 230 mm (15.75 in x 15.75 in x 9.06 in)
Net Weight: (each)	0.5 kg (1.1 lb)	12.05 kg (26.55 lb)
Shipping Weight:	1 sub and 4 satellites: 18.26 kg (40.25 lb)	
Included Accessories:	Wall bracket; hex wrench	Wall bracket; hex wrench

1. Half space (wall mounting).
2. Long Term Program Rating, 3 dB greater than continuous noise pink noise rating.
3. Average 1 kHz – 4 kHz.
4. Average 1 kHz – 8 kHz.

7.2.1 Frequency response

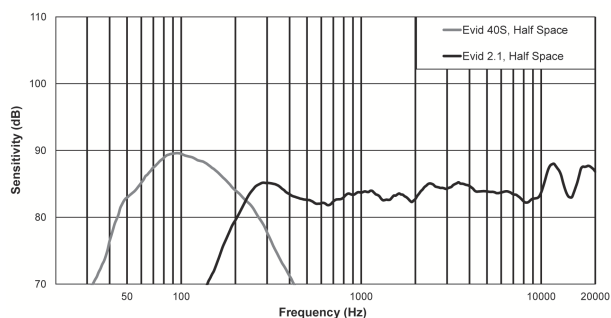

8 Notes

Bosch Security Systems, Inc

12000 Portland Avenue South

Burnsville MN 55337

USA

www.electrovoice.com

© Bosch Security Systems, Inc, 2015
