

EVID High Performance Ceiling Speakers

EVID-PC6.2E | EVID-PC8.2E

en | Installation Note



Table of contents

1	Safety	4
1.1	Notices	4
2	Introduction	5
2.1	Important features	5
3	System overview	6
3.1	Packing list	6
3.2	Product feature identification	7
3.3	Dimensions	7
3.4	Frequency response and impedance	8
3.5	Beamwidth	8
3.6	Directivity	8
3.7	Equalization	9
4	Installation	10
5	Troubleshooting	14
6	Technical data	15

1 Safety



Warning!

Suspending any object is potentially dangerous and should only be attempted by individuals who have a thorough knowledge of the techniques and regulations of suspending objects overhead. Electro-Voice strongly recommends all loudspeakers be suspended taking into account all current national, federal, state, and local laws and regulations. It is the responsibility of the installer to ensure all loudspeakers are safely installed in accordance with all such requirements. When loudspeakers are suspended, Electro-Voice strongly recommends the system be inspected at least once per year or as laws and regulations require. If any sign of weakness or damage is detected, remedial action should be taken immediately. The user is responsible for making sure the wall, ceiling, or structure is capable of supporting all objects suspended overhead. Any hardware used to suspend a loudspeaker not associated with Electro-Voice is the responsibility of others.



Caution!

The seismic tab (auxiliary support ring) is not intended for primary suspension of the loudspeaker. The seismic tab should only be used as a secondary safety point.



Caution!

When using the weatherized terminal cover, the original auxiliary support ring is no longer used. Attach the safety cable to the auxiliary support ring on the weatherized terminal cover.



Caution!

Ceiling mount speaker's safety cable
The safety cable should be installed with a minimum of 3-inches (76.2 mm) of slack.

1.1

Notices

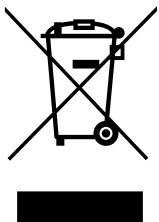

Old electrical and electronic appliances

Electrical or electronic devices that are no longer serviceable must be collected separately and sent for environmentally compatible recycling (in accordance with the European Waste Electrical and Electronic Equipment Directive).

To dispose of old electrical or electronic devices, you should use the return and collection systems put in place in the country concerned.

2 Introduction

EVID Premium Ceiling Speakers use innovative design and materials to provide high performance in a flush-mount ceiling format. The rear input cover for EN54 is used to create a seal to protect the ceiling speaker from moisture and foreign particles, if properly installed. The weatherized terminal cover must be used in all EN54 installations. Two models comprise the family: EVID-PC6.2E and EVID-PC8.2E.

Read through this manual to familiarize yourself with the safety information, features, and applications before you use these products.

2.1 Important features

EVID-PC6.2E – 6-inch Premium Ceiling Speaker

- High output true compression driver for wide dispersion and superior coverage control out to 20 kHz
- Long throw 6.5 inch (165 mm) woofer housed in a large vented steel enclosure for extended LF performance down to 50 Hz
- 100 watt power handling provides for 95 dB maximum SPL
- Front baffle transformer tap adjustment switch
- Includes tile rails, “C” mounting ring, and weatherized terminal cover

EVID-PC8.2E – 8-inch Premium Ceiling Speaker

- High output true compression driver for wide dispersion and superior coverage control out to 20 kHz
- Long throw 8-inch (200 mm) woofer housed in a large vented 14 gauge steel enclosure for extended LF performance down to 40 Hz
- 100 watt power handling provides for 95 dB maximum SPL
- Front baffle transformer tap adjustment switch
- Includes tile rails, “C” mounting ring, and weatherized terminal cover

3 System overview

3.1 Packing list

Item	Quantity	Description
A	2	Speaker system
B	4	Tile rails
C	2	C-ring support
D	2	Grille
E	1	Manual
F	4	Support ring screws
G	2	Terminal connector
H	1	Cutout template
I	2	Weatherized terminal cover
J	2	Gland nut
K	8	Screws

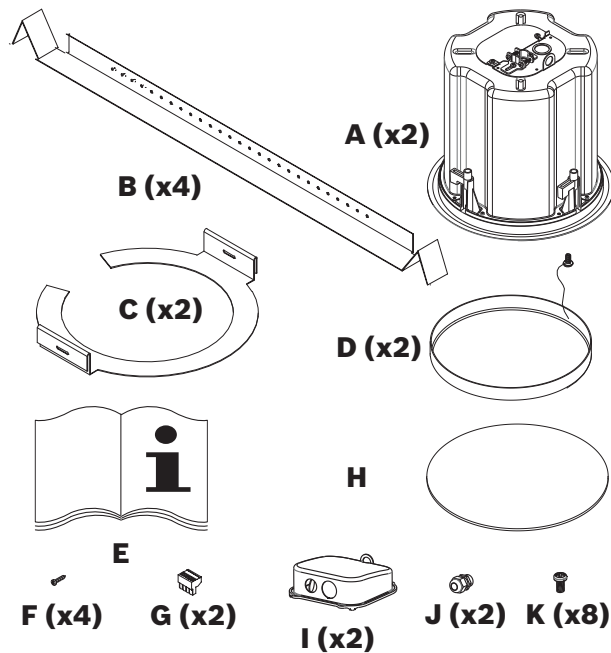

Figure 3.1: Components in kit

3.2 Product feature identification

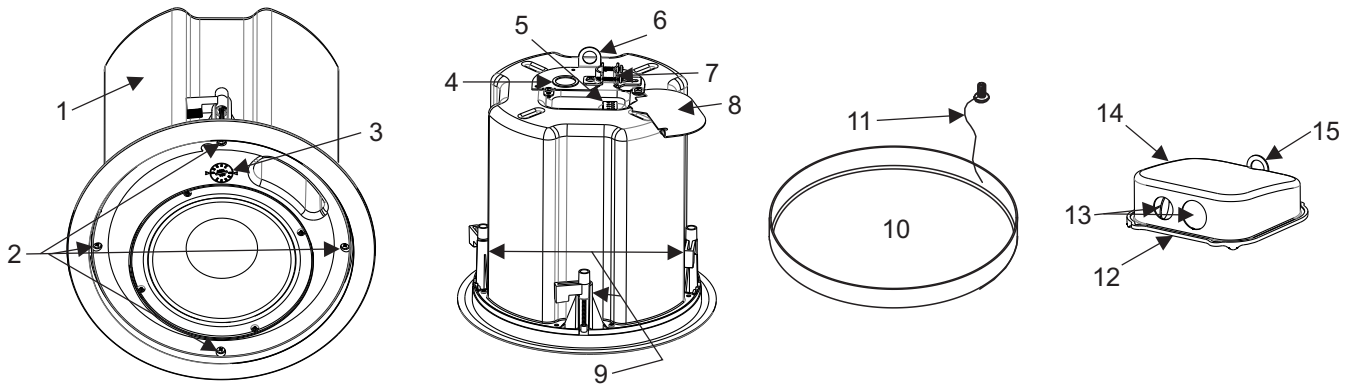

Figure 3.2: Bottom and top of the ceiling speaker

Item	Description	Item	Description
1	Steel backcan	9	Rotating mounting tabs
2	Mounting screws	10	Grille
3	Tap selector	11	Grille safety tether
4	Conduit knockout	12	Gasket attached to the cover
5	Removable input terminal connector	13	Knock out holes
6	Seismic tab (auxiliary support ring)	14	Weatherized terminal cover
7	Strain relief fitting	15	Seismic tab (auxiliary support ring)
8	Terminal cover plate		

3.3 Dimensions

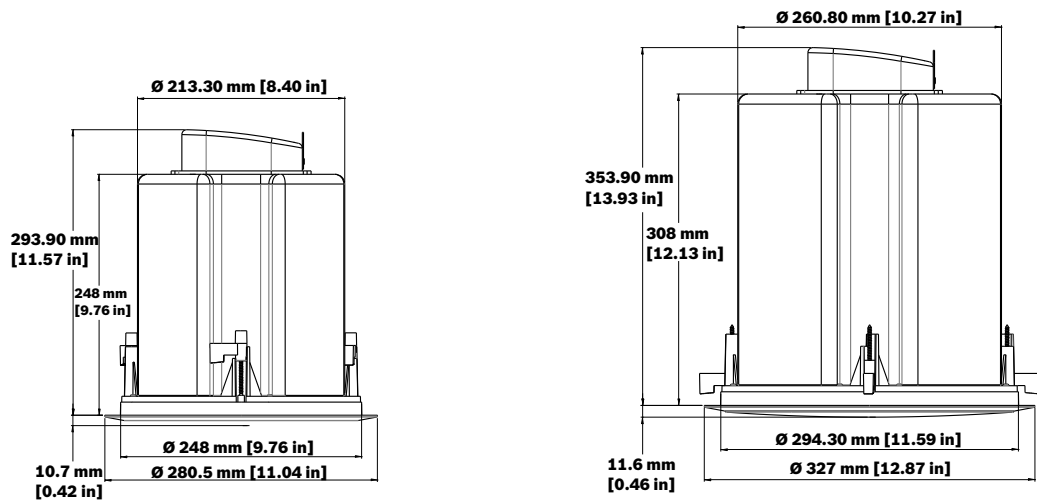
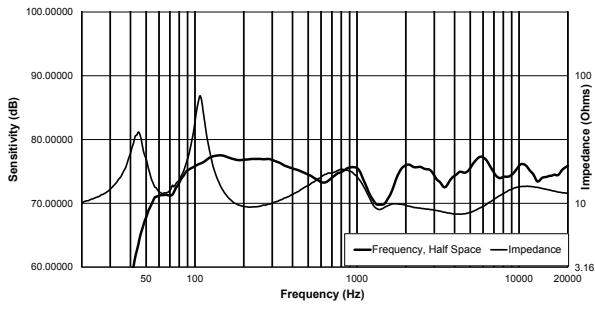
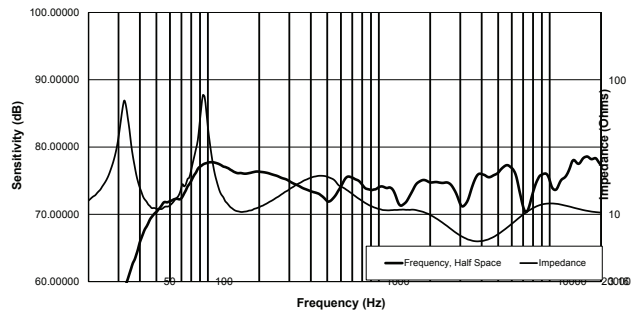

Figure 3.3: EVID-PC6.2E (left) and EVID-PC8.2E (right) dimensions

3.4 Frequency response and impedance



EVID-PC6.2E Frequency Response and Impedance 1 watt / 4 meters / on axis (With EN54 required equalization applied)



EVID-PC8.2E Frequency Response and Impedance 1 watt / 4 meters / on axis (With EN54 required equalization applied)

3.5 Beamwidth

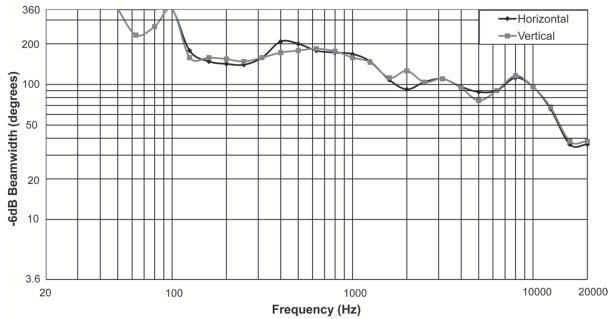

EVID-PC6.2E Beamwidth

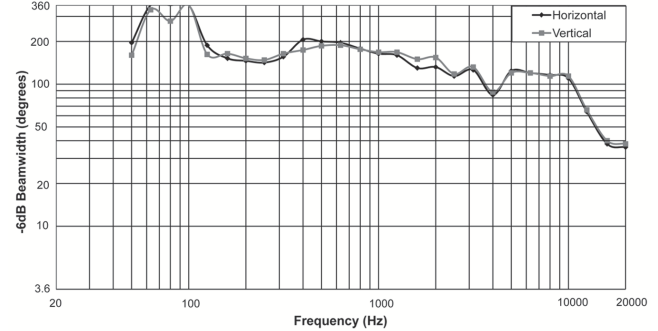

EVID-PC8.2E Beamwidth

3.6 Directivity

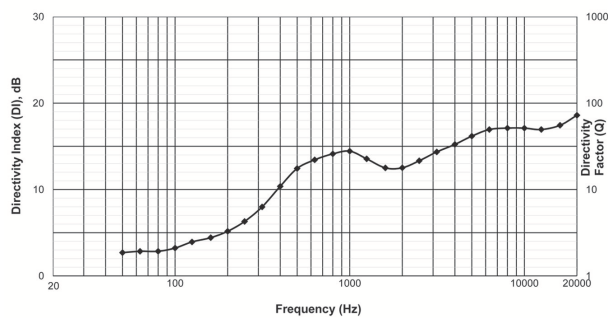

EVID-PC6.2E Directivity

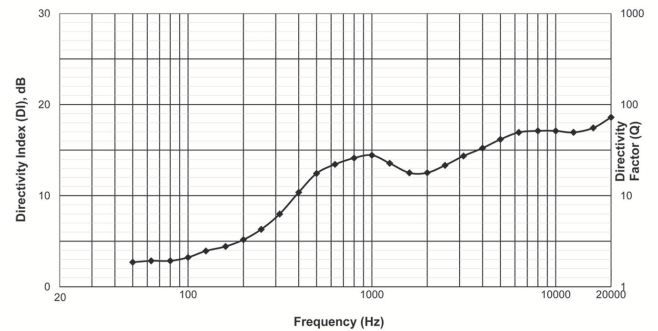

EVID-PC8.2E Directivity

3.7 Equalization

When used in an EN54 installation the following equalization must be applied to the speakers:

EVID PC6.2E	EVID PC8.2E
PEQ Frequency: 180 Hz	PEQ Frequency: 152 Hz
PEQ Filter Q: 2.0	PEQ Filter Q: 2.0
PEQ Gain: -6.0 dB	PEQ Gain: -8.0 dB

4 Installation

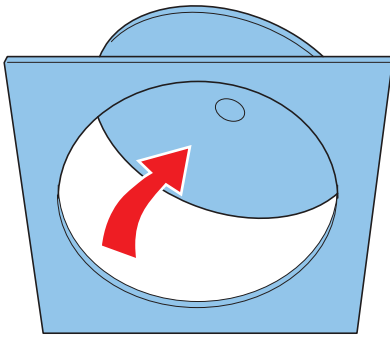

Figure 4.1: Trace cutout template

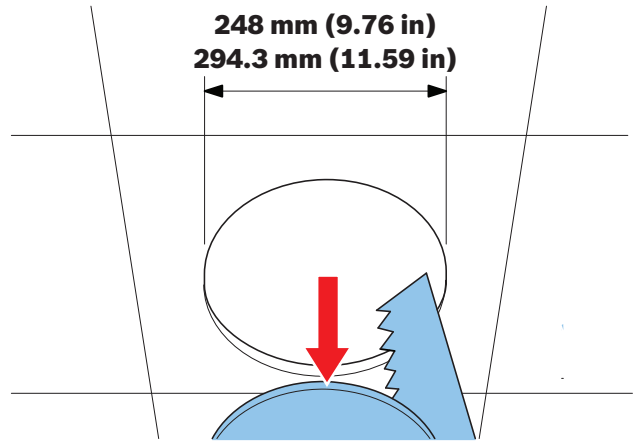

Figure 4.2: Cut hole

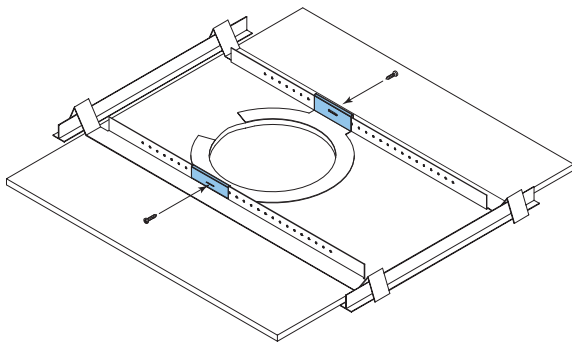

Figure 4.3: Secure rails to C-Ring

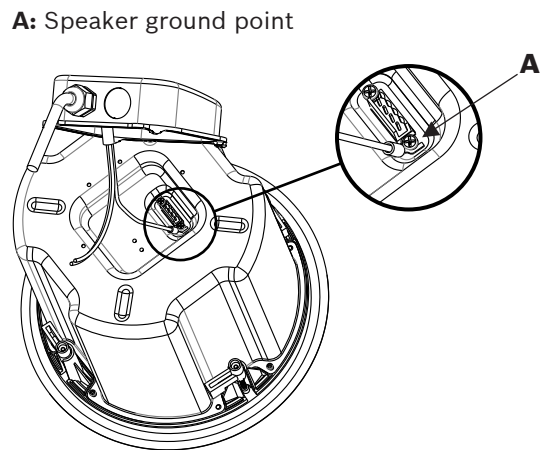

Figure 4.4: Wiring – ground point

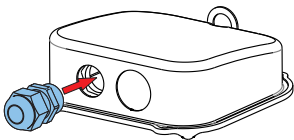

Figure 4.5: Install the gland nut into the cover

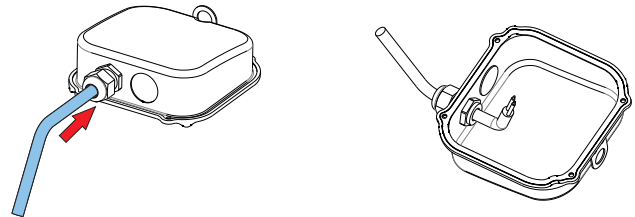

Figure 4.6: Run the wire cable through the gland nut.

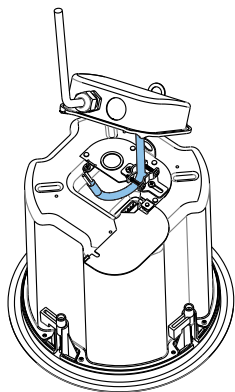

Figure 4.7: Run the wire cable through the clamp.

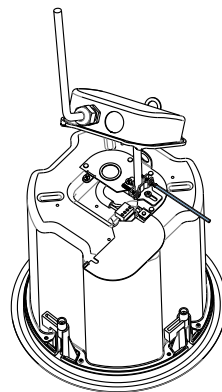

Figure 4.8: Tighten the clamp down onto the wire.

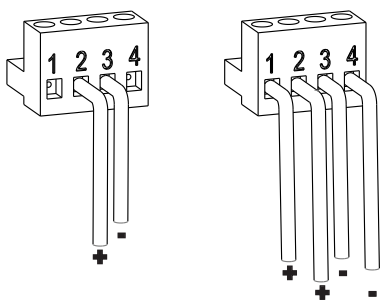

Figure 4.9: Wiring single (left) double (right)

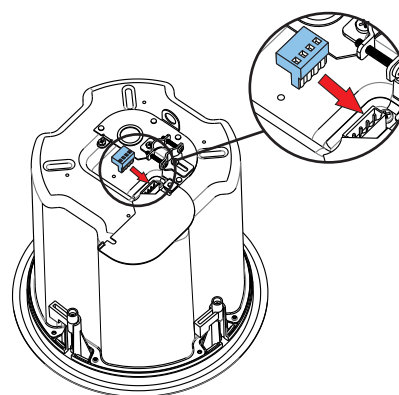

Figure 4.10: Install the phoenix connector

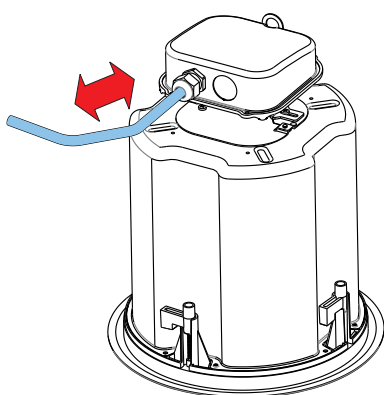

Figure 4.11: Adjust the length of the wire from the gland nut.

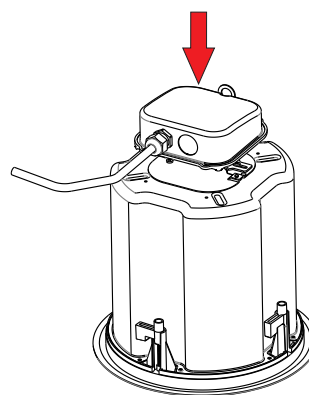

Figure 4.12: Hold the wire while lowering the cover

EVID High Performance Ceiling Speakers

B: Recommended installation torque is 10–14 in/lb (1.13–1.58 Newton Meters)a

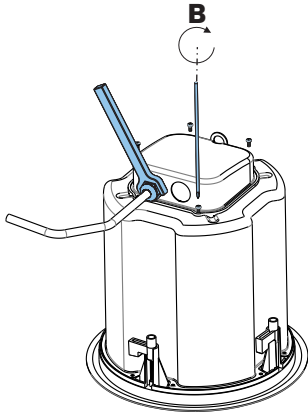

Figure 4.13: Tighten four (4) screws to attach the cover and tighten the gland nut

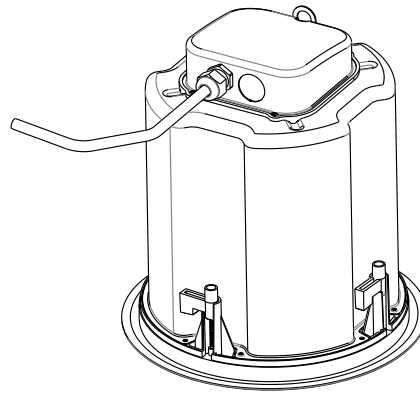

Figure 4.14: Weatherized terminal cover is attached



Caution!

When using the weatherized terminal cover, the original auxiliary support ring is no longer used. Attach the safety cable to the auxiliary support ring on the weatherized terminal cover.



Caution!

Ceiling mount speaker's safety cable
The safety cable should be installed with a minimum of 3-inches (76.2 mm) of slack.

C: Recommended auxiliary support line slack is 76.2 mm–305 mm (3 in–12 in).

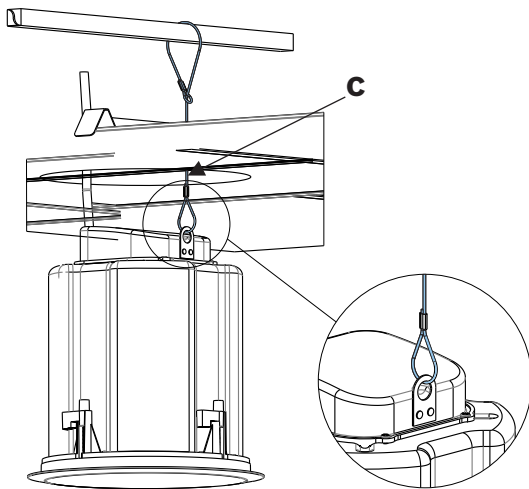

Figure 4.15: Attach auxiliary support line

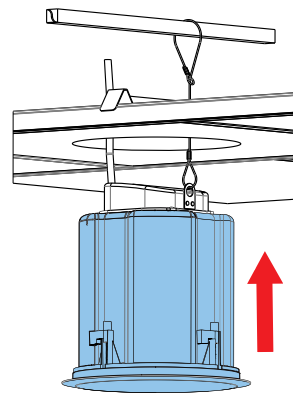

Figure 4.16: Install the speaker into the ceiling

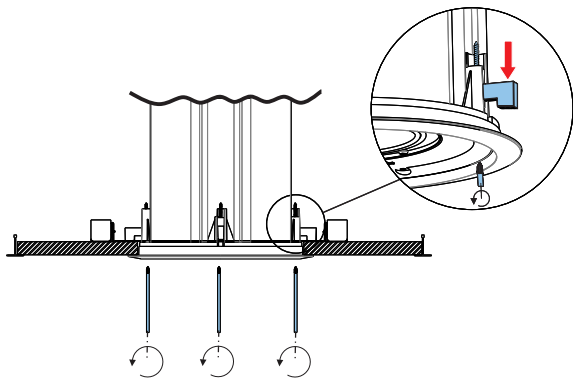

Figure 4.17: Tighten mounting tabs

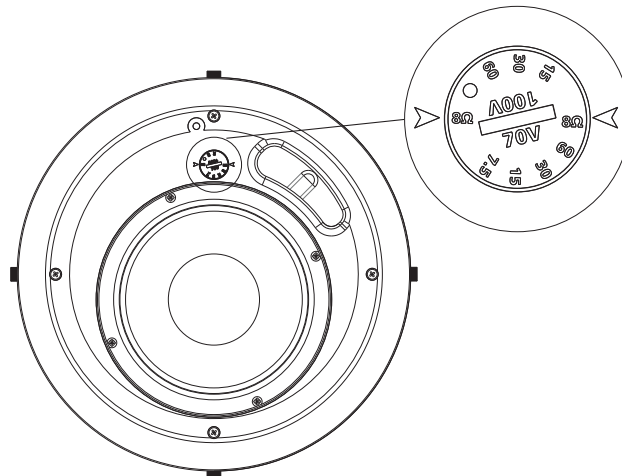

Figure 4.18: Tap selector

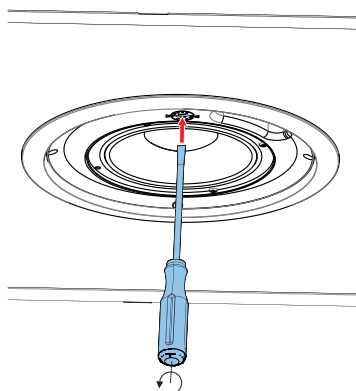

Figure 4.19: Adjust tap selector

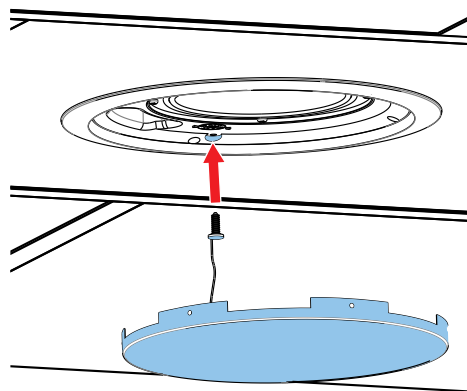

Figure 4.20: Insert grille tether

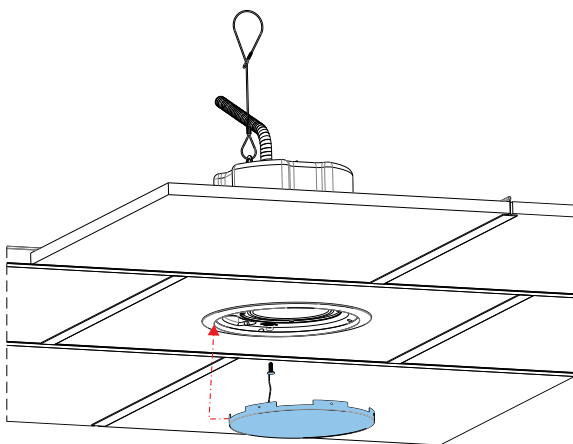

Figure 4.21: Attach the grille

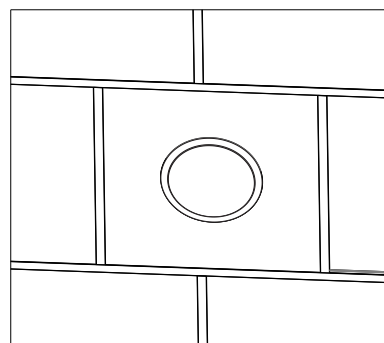

Figure 4.22: Installation complete

5 Troubleshooting

Problem	Possible Causes	Action
No output	Amplifier	<p>Ensure the amplifier channel is being fed an input signal (preferably via a signal input indicator on the amplifier).</p> <p>Verify the amplifier channel's volume is turned up.</p> <p>Connect the loudspeaker and cable, which had no output to another amplifier channel, ensuring an input signal is fed to the new amplifier channel. If you then get output, the problem was the amplifier channel. If not, then the problem is either the cable or the loudspeaker.</p>
	Loudspeaker cables(s)	Replace the cable(s) connecting the loudspeaker system and amplifier.
Questionable or intermittent output, such as crackling	Faulty connection	Ensure all cabling for proper connector contact. A bad connection can result in intermittent contact or dramatically increased resistance, which in turn can cause reduces output or noises unrelated to the signal.
	Improper power tap setting	Verify the power tap setting under the loudspeaker grille is appropriate for the installation and amplifier chosen.
Constant noise such as buzzing, hissing, or humming	A faulty electronic device in the signal chain	Loudspeakers cannot generate these sounds by themselves; you may have a faulty electronic device in the signal chain.
	Poor system grounding	Check and correct the system grounding, as required.
Poor low-frequency output	Out-of-polarity hookup between multiple loudspeakers	When two loudspeakers are hooked up out of polarity (out of phase), the low frequencies cancel each other out. Try reversing the polarity of one of the loudspeakers either by turning around a dual-banana plug at the amplifier or by reversing the tip/sleeve leads on the jack. Which ever condition results in greater low-frequency output is the in-polarity condition.

If these suggestions do not solve your problem, contact your nearest Electro-Voice dealer or Electro-Voice distributor.

6 Technical data

	EVID-PC6.2E	EVID-PC8.2E
Frequency Range (-10 db):	50 Hz – 20 kHz	40 Hz – 20 kHz
Nominal Coverage (Conical):	100°	120°
Power Handling (Direct Coupled):	200 W Program, 100 W Pink Noise as per EN54-24 standard	
Sensitivity per EN54-24 standard (SPL 1 W / 4 m):	75 dB	74.5 dB
Max Calculated SPL per EN54-24 standard:	60 watt Transformer coupled @ 4 meters: 92 dB 100 watt Direct coupled @ 4 meters: 95 dB	60 watt Transformer coupled @ 4 meters: 92 dB 100 watt Direct coupled @ 4 meters: 95 dB
Impedance:	Direct Coupled: 8 Ohms 70V Transformer Coupled: 60 watt/83Ω, 30 watt/167Ω, 15 watt/333Ω, 7.5 watt/667Ω 100v Transformer Coupled: 60watt/167Ω, 30 watt/333Ω, 15 watt/667Ω	
LF Transducer:	165 mm (6.5 in)	200 mm (8 in)
HF Transducer:	35 mm Compression Driver	
Transformer Taps:	70V: 60W, 30W, 15W, 7.5W, 8 ohm 100V: 60W, 30W, 15W, 8 ohm	
Connectors:	Removable locking 4-pin (Phoenix) 2.5 mm (12 AWG) max wire size	
Enclosure:	ABS Plastic (UL94V-O) Baffle, steel back can	
Grille:	Color matched steel grille with fabric	
Dimensions (H x Dia):	294 mm x 280 mm (11.57 in x 11.0 in)	354 mm x 327 mm (13.94 in x 12.87 in)
Cutout Size:	248 mm (9.76 in)	294.3 mm (11.59 in)
Net Weight:	7.33 kg (16.15 lb)	8.19 kg (18.05 lb)
Shipping Weight (pair):	17.51 kg (38.6 lb)	20.91 kg (46.1 lb)
Support Hardware:	C Ring, Tile Bridge, Weatherized Terminal Cover	
Approvals:	UL1480, 2043; CE, EN54-24:2008	

Notice!



The specifications data was measured in an anechoic chamber according to EN 54-24.
Reference axis: Axis is on the center of grille surface and perpendicular to the grille surface.
Reference plane: Plane is on the grille surface and perpendicular to the reference axis.
Horizontal plane: Plane is containing the reference axis and perpendicular to the reference plane.

EVID High Performance Ceiling Speakers

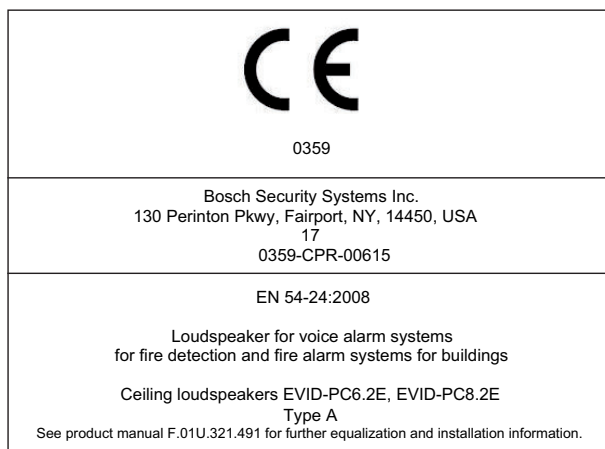

Frequency	Reproducibility		Horizontal Coverage		Vertical Coverage	
	EVID-PC8.2E	EVID-PC6.2E	EVID-PC8.2E	EVID-PC6.2E	EVID-PC8.2E	EVID-PC6.2E
(HZ)	dB/SPL	dB/SPL	Degrees	Degrees	Degrees	Degrees
500	57.77	60.55	170	175	170	175
630	59.94	60.16				
800	60.83	62.69				
1000	60.91	61.74	160	160	160	160
1250	59.94	56.57				
1600	62.09	59.72				
2000	61.69	61.05	100	120	100	120
2500	61.47	60.89				
3150	63.52	62.36				
4000	63.49	62.99	85	90	85	90

Table 6.1: Reproducibility and coverage angles measured on an EN54-24 specified test baffle at 4 meters Signal at 1 watt of 1/3 octave band filtered pink noise.

Bosch Sicherheitssysteme GmbH

Robert-Bosch-Ring 5

85630 Grasbrunn

Germany

www.boschsecurity.com

© Bosch Sicherheitssysteme GmbH, 2017

Bosch Security Systems, Inc

12000 Portland Avenue South

Burnsville MN 55337

USA

www.electrovoice.com

