

# X12-125F-AG GRID ADAPTER FOR X1/X2 TO X12-125F

- Couples one or more X12-125F subwoofers to X1 or X2 loudspeakers
- Supports up to nine X1 or X2 loudspeakers below X12-125F subwoofers
- Lightweight aluminum construction

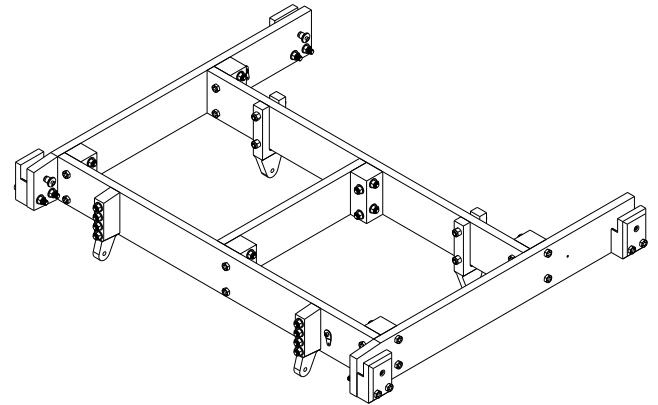

The X12-125F-AG adaptor grid safely suspends up to nine X1 or X2 full-range loudspeakers below X12-125F subwoofers in a single flown mixed array. Model the array in LAPS 3.4 or higher before deployment to ensure that the configuration is valid and safe.

## Technical specifications

Color:	Black
Dimensions (H x W x D):	178 mm x 996 mm x 763 mm (7.0 in x 39.2 in x 30.0 in)
Net weight:	60.3 lb (27.4 kg)
Shipping weight:	74.5 lb (34.3 kg)
<b>Compatible System Solutions:</b>	
X1-212/90 90° Full-Range Line Array Element	
X2-212/90 90° Full-Range Line Array Element	
X1-212/120 120° Full-Range Line Array Element	
X2-212/120 120° Full-Range Line Array Element	
X12-125F 2X15" flying subwoofer	

### Dimensions:

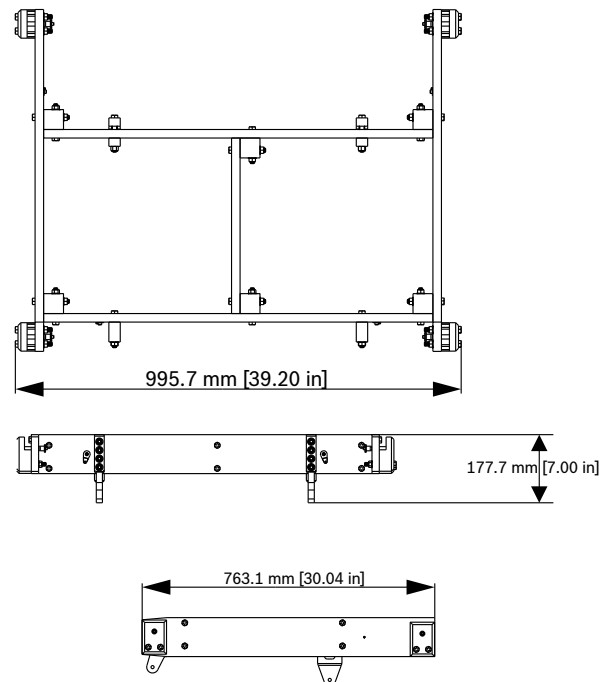

**Caution!**



Electro-Voice loudspeakers and rigging accessories should be suspended overhead only in accordance with the procedures and limitations specified in the user documentation and installation manual. Electro-Voice products should be suspended with certified rigging hardware by an authorized rigging professional and in complete compliance with local, state, and federal overhead suspension ordinances.

For more information, see the X-LINE ADVANCE Systems Installation manual (F.01U.310.953).

## Parts included

Quantity	Component
1	Adapter grid assembly
1	Datasheet
1	Warranty card

## Ordering information

**X12-125F-AG GRID ADAPTER FOR X1/X2 TO X12-125F**  
Grid adapter for X1/X2 to X12-125F, black  
Order number **X12-125F-AG**

**Represented by:**

**Germany:**  
Bosch Sicherheitssysteme GmbH  
Robert-Bosch-Ring 5  
85630 Grasbrunn  
Germany

Bosch Security Systems, Inc.  
12000 Portland Avenue South  
Burnsville MN 55337  
USA

[www.electrovoice.com](http://www.electrovoice.com)