

## **EVID-C-G2 Ceiling Loudspeakers**

EVID-C4.2-G2, EVID-C4.2LP-G2, EVID-C6.2-G2, EVID-C6.2LP-G2,  
EVID-C8.2-G2, EVID-C8.2HC-G2, EVID-C8.1S-G2

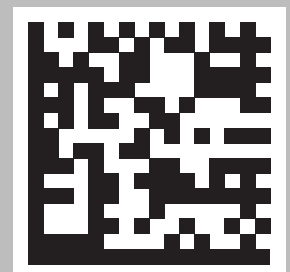

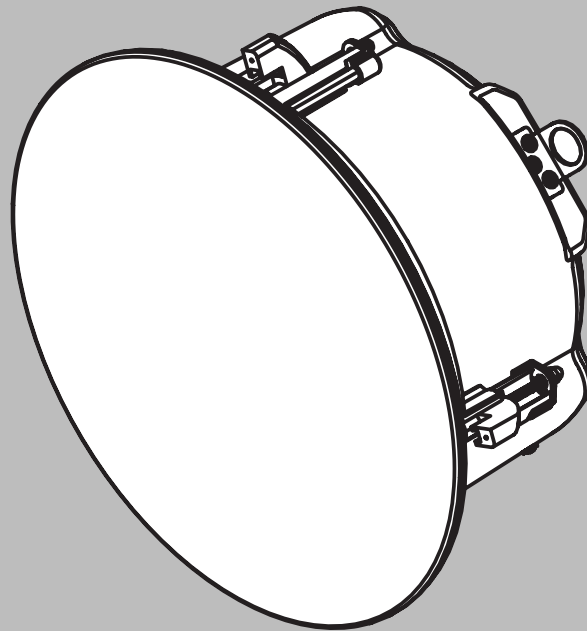

## Table of contents

<b>1</b>	<b>Safety</b>	<b>4</b>
1.1	Notices	5
<b>2</b>	<b>Introduction</b>	<b>6</b>
2.1	Model description	6
<b>3</b>	<b>System overview</b>	<b>8</b>
3.1	System features	8
3.2	Parts included	8
3.3	Product information	8
<b>4</b>	<b>Installation and wiring</b>	<b>9</b>
4.1	Cutting the hole	9
4.2	Installing C-Ring and/or tile rails	10
4.3	Attaching wiring to the terminal connector	11
4.4	Securing the cable to the speaker	13
4.5	Reinstalling the terminal cover plate	14
4.6	Mounting the speaker into the ceiling	15
4.7	Adjusting the tap selector	16
4.8	Attaching the grille	16
<b>5</b>	<b>Troubleshooting</b>	<b>18</b>
<b>6</b>	<b>Technical data</b>	<b>19</b>
<b>7</b>	<b>Appendices</b>	<b>29</b>
7.1	Painting the speaker grille	29
7.2	Protecting the speaker grille while painting the room	29
7.3	System design guide	30
7.3.1	Selecting and positioning ceiling loudspeakers	30
7.3.2	Ceiling systems: size vs. coverage	30
7.3.3	Use of subwoofers	32

# 1 Safety



## Warning!

Suspending any object is potentially dangerous and should only be attempted by individuals who have a thorough knowledge of the techniques and regulations of suspending objects overhead. Electro-Voice strongly recommends that loudspeakers be suspended taking into account all current national, federal, state, and local laws and regulations. It is the responsibility of the installer to ensure all loudspeakers are safely installed in accordance with all such requirements. When loudspeakers are suspended, Electro-Voice strongly recommends the system be inspected at least once per year or as laws and regulations require. If any sign of weakness or damage is detected, remedial action should be taken immediately. The user is responsible for making sure the wall, ceiling, or structure is capable of supporting all objects suspended overhead. Any hardware used to suspend a loudspeaker not associated with Electro-Voice is the responsibility of others.



## Caution!

Amplifier outputs may carry output voltages up to 100 V<sub>RMS</sub>. Touching uninsulated terminals or wiring may result in an unpleasant sensation. The external wiring of these terminals requires installation by an instructed person.

## Safety point

As an added safety measure, it is strongly recommended to utilize a properly rated secondary safety cable (provided by the installer) to securely fasten the speaker from the safety point on its back to a secondary mounting structure on the building.



## Caution!

The safety point (auxiliary support ring) is not intended for primary suspension of the loudspeaker. The safety point should only be used as a secondary safety point.



## Caution!

Ceiling mount speaker's safety cable

The safety cable should be installed with 1 - 6 inches (25.4 - 152.4 mm) of slack.

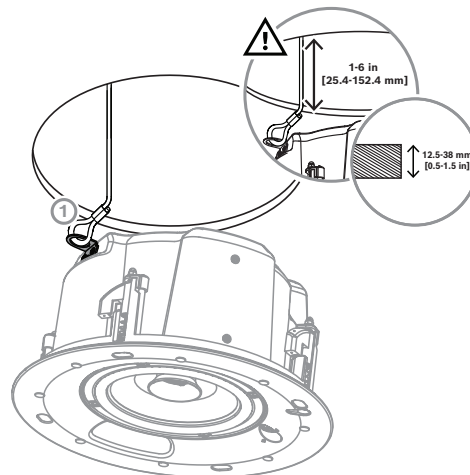

**Notice!****ATTENTION: UL SAFETY LISTING**

All EVID ceiling speaker models are listed under UL standard UL 1480A as a signaling speaker. All models are also suitable for use in air handling spaces per UL 2043.

**1.1****Notices****Old electrical and electronic appliances**

Electrical or electronic devices that are no longer serviceable must be collected separately and sent for environmentally compatible recycling (in accordance with the European Waste Electrical and Electronic Equipment Directive).

To dispose of old electrical or electronic devices, you should use the return and collection systems put in place in the country concerned.

**Copyright and disclaimer**

All rights reserved. No part of this document may be reproduced or transmitted in any form by any means, electronic, mechanical, photocopying, recording, or otherwise, without the prior written permission of the publisher. For information on getting permission for reprints and excerpts, contact Electro-Voice.

All content including specifications, data, and illustrations in this manual are subject to change without prior notice.

## 2 Introduction

Thank you for purchasing EVID-C-G2 Ceiling Loudspeakers. Read through this manual to familiarize yourself with features, applications, and precautions before you use these products.

EVID-C-G2 Ceiling Loudspeakers use innovative design and materials to provide premium-level performance in a flush-mount ceiling format.

Seven models comprise the EVID-C-G2 Series Ceiling Loudspeakers:

- EVID-C4.2-G2 with a 4-inch LF driver and a 0.75-inch, soft-dome tweeter.
- EVID-C4.2LP-G2 with a 4-inch LF driver and a 0.75-inch, soft-dome tweeter in a low profile.
- EVID-C6.2-G2 with a 6.5-inch LF driver and a 1-inch titanium tweeter.
- EVID-C6.2LP-G2 with a 6.5-inch LF driver and a 1-inch titanium tweeter in a low profile.
- EVID-C8.2-G2 with an 8-inch LF driver and a 1-inch titanium tweeter with waveguide.
- EVID-C8.2HC-G2 with an 8-inch, ring aperture loaded LF driver, with a fully waveguide-loaded 1-inch titanium tweeter.
- EVID-C8.1S-G2, a true ceiling-mounted 8-inch subwoofer designed to augment and extend the full-range model's low-frequency response.

### 2.1 Model description

#### EVID-C4.2-G2

Excellent bandwidth in a clean and unobtrusive profile, with a flat-grille and a rimless design. 4-inch woofer and soft-dome tweeter give a smooth sound and wide coverage angle, making it excellent for lower ceiling heights, and anywhere where wider coverage is needed. Features our new 3-point SwiftLock System for quick, easy, and safe installations.

#### EVID-C4.2LP-G2

The EVID-C4.2LP-G2 is similar to the EVID-C4.2-G2, but in a low profile.

4-inch woofer and soft-dome tweeter give a smooth sound and wide coverage angle, making it excellent for lower ceiling heights, and anywhere wider coverage is needed. Its shallow enclosure design makes it ideal for locations where installation space is limited. Features our new 4-point SwiftLock System for quick, easy, and safe installations.

The EVID-C4.2LP-G2 shares the same mounting hole and grille as the EVID-C6.2-G2, EVID-C8.2-G2, making it an excellent choice to fit in those unexpected shallow mounting locations.

#### EVID-C6.2-G2

Excellent bandwidth in a clean and unobtrusive profile, with a flat-grille and a rimless design.

6.5-inch woofer and titanium tweeter give an extended frequency response, perfect for use almost anywhere a flush-mounted design is desired, with demand for high-quality audio. Features our new 4-point SwiftLock System for quick, easy, and safe installations.

The EVID-C6.2-G2 shares the same mounting hole and grille as the EVID-C4.2LP-G2, EVID-C8.2-G2, making these an excellent choice for any space, even when shallow mounting locations are present.

#### EVID-C6.2LP-G2

The EVID-C6.2LP-G2 is similar to the EVID-C6.2-G2, but in a low profile.

Excellent bandwidth in a clean and unobtrusive profile, with a flat-grille and a rimless design.

6.5-inch woofer and titanium tweeter give an extended frequency response, perfect for use almost anywhere a flush-mounted design is desired, with demand for high-quality audio. Its shallow enclosure design makes it ideal for locations where installation space is limited.

Features our new 4-point SwiftLock System for quick, easy, and safe installations. The EVID-C6.2LP-G2 shares the same mounting hole and grille as the EVID-C8.2HC-G2, EVID-C8.1S-G2.

#### **EVID-C8.2-G2**

Excellent bandwidth in a clean and unobtrusive profile, with a flat-grille and a rimless design. 8-inch woofer and waveguide-loaded titanium tweeter give an extended frequency response with a more powerful bass response, perfect for use in applications where higher output or more controlled coverage is desired. Features our new 4-point SwiftLock System for quick, easy, and safe installations. The EVID-C8.2-G2 shares the same mounting hole and grille as the EVID-C4.2LP-G2, EVID-C6.2-G2, making these an excellent choice for any space, even when shallow mounting locations are present.

#### **EVID-C8.2HC-G2**

Excellent bandwidth in a clean and unobtrusive profile, with a rimless design. 8-inch, ring aperture loaded LF driver, and fully waveguide-loaded 1-inch titanium tweeter, provide a highly controlled coverage pattern with high sensitivity, ideal for high ceiling installations, or anywhere high-output in a tighter controlled pattern are needed. Features our new 4-point SwiftLock System for quick, easy, and safe installations. The EVID-C8.2HC-G2 shares the same mounting hole and grille as the EVID-C6.2LP-G2, EVID-C8.1S-G2.

#### **EVID-C8.1S-G2**

The EVID-C8.1S-G2 packs an 8-inch subwoofer in a tuned high performance enclosure to give amazing low frequency performance down to 45 Hz. It is one of the few quick-mount ceiling true subwoofers available. Flexible installation and powerful low-end performance make it the ideal mate to any EVID-G2 ceiling model. The subwoofer is designed for use in passive, full range systems. Bi-amplification is not required.

## 3 System overview

### 3.1 System features

- SwiftLock mounting system for quick, safe, and reliable installation
- Bezel-less design with easy-attach magnetic grille
- Front baffle wattage tap adjustment
- Includes tile rail and C-Ring for easy installation
- UL 1480A, UL 2043, CSA C22.2 No. 205 and IEC 62368-1 certified

### 3.2 Parts included

Make sure that all parts are included and not damaged. If the packaging or any parts are damaged, contact your shipper. If any parts are missing, contact your Sales or Customer Service Representative.

Quantity	Component
2	Ceiling loudspeaker
2	Loudspeaker connection cover (installed)
2	Magnetic grille
4	Ceiling tile rail
2	C-ring
4	Screw
1	Cutout template
2	Paint cover
1	Quick installation guide

### 3.3 Product information

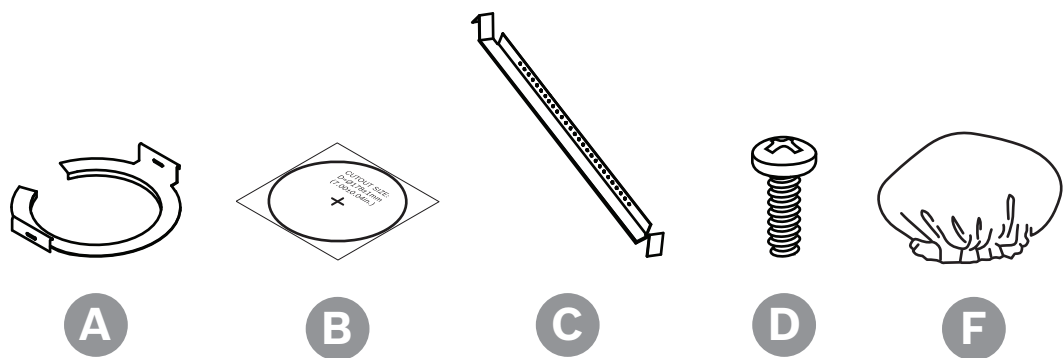

A	C-Ring
B	Cutout template
C	Ceiling tile rail
D	Screw
F	Paint cover

## 4 Installation and wiring

Our new SwiftLock System allows for quick, simple, and reliable mounting of the ceiling speaker, leaving both hands free to complete tightening the speaker to the ceiling. The wiring is on the side of the speaker, reducing the clearance space required to install the speaker, and making it easier to access while mounting the speaker from underneath, as well as on suspended ceiling grids where the speaker can be accessed from a side ceiling tile.

EVID-C-G2 Ceiling Loudspeakers include typical installation hardware for either suspended ceilings or sheetrock ceilings. Mounting tabs securely grip the ceiling material and hold the ceiling speaker assembly in place. Input wiring is attached to a removable terminal block connector that can be prewired before speaker installation to speed up the installation process.

### Use of optional rough-in accessories

For most installations, no additional hardware is required. However, RR Series mounting plates aid in the installation of the EVID-C-G2 Series Ceiling Loudspeakers in sheetrock or plaster ceiling installations. The rough-in accessories provide a cutout guide when many holes are to be made in a production-line style installation and to ensure the speakers are positioned correctly as the holes are cut in the sheetrock.

### RR Series mounting plates

RR series mounting plates are made of flat sheet metal with holes to attach to the joists or trusses of a building structure.

The mounting holes are provided for nails or screws at 16 inches (406 mm), 20 inches (508 mm) and 24 inches (610 mm) on-center. The installer can drill other holes as needed up to a maximum of 24-3/4 inches (630 mm) apart.

The sheetrock installs over the plate and the plate provides a template for a blind cutout of the hole in the sheet rock. A router-type cutting tool cuts the ceiling material using the plate ring as a cutout guide.

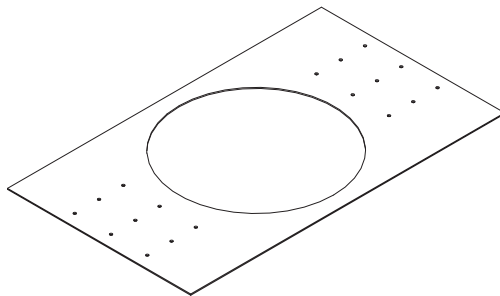

Figure 4.1: Speaker mounting plate



### Notice!

#### Controlling vibration

Because of their high performance, EVID-C-G2 Ceiling Loudspeakers can generate substantial vibration, which can cause buzzing in loose sections of the ceiling structure. Depending on the character of the ceiling tile and related components, dampening material may be required under the tile rails or the edges of the tiles to eliminate rattles.

## 4.1 Cutting the hole

### Cutting the ceiling hole

To cut the hole in suspended tile or sheetrock ceilings:

- Trace the cutout template

Or

- Use a circular cutter set to the appropriate cutout size.

If the wire has been pre-installed, pull the wiring through the cutout hole.

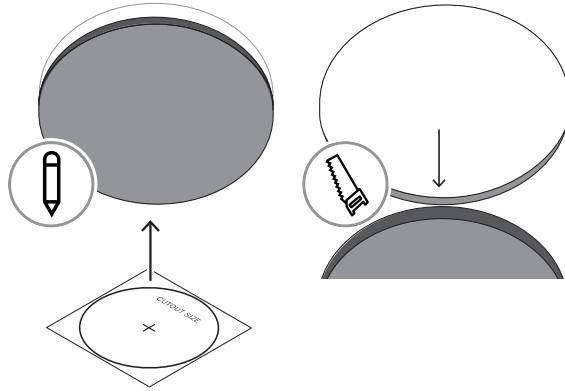

#### Cutout dimensions

	EVID-C4.2-G2	EVID-C4.2LP-G2 EVID-C6.2-G2 EVID-C8.2-G2	EVID-C6.2LP-G2 EVID-C8.1S-G2 EVID-C8.2HC-G2
<b>Mounting cutout (in)</b>	7.2 in	10.7 in	12.7 in
<b>Mounting cutout (mm)</b>	183 mm	272 mm	322 mm

## 4.2

### Installing C-Ring and/or tile rails

All EVID-C-G2 Ceiling Loudspeakers include two types of backing hardware:

- One (1) C-Ring
- Two (2) tile rails

#### Suspended ceiling installations

To install the C-Ring and the tile rails:

1. Insert the C-Ring through the hole cut in the ceiling tile.
2. Place the C-Ring around the hole with the tabs located.

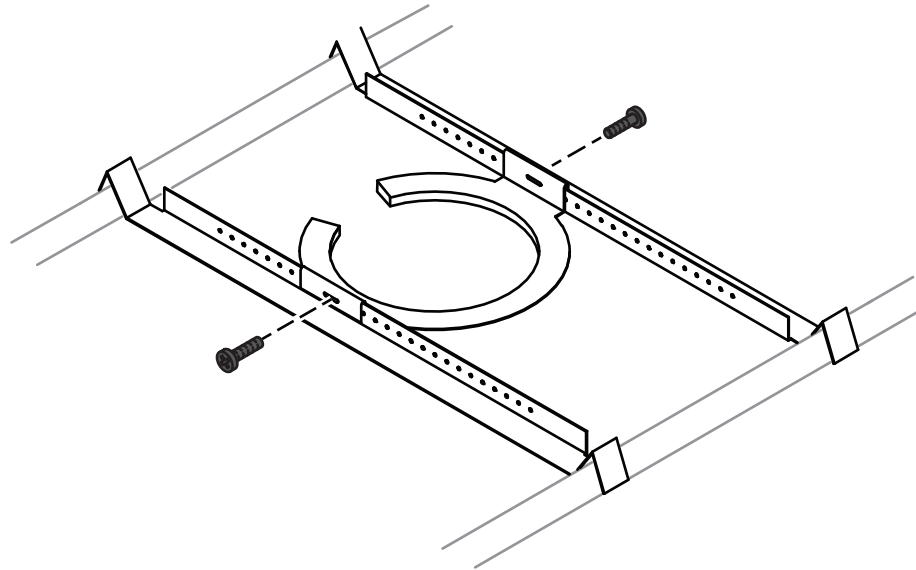

3. Insert the tile rails through the cut hole in the ceiling tile.
4. Snap the two rails into the two tabs in the C-Ring and align the rails so that the ends extend over the T-channel grid on the side of the tile.
5. Secure the rails onto the C-Ring tabs by inserting a screw through each tab into the rail.

The tile rails fit either standard 24-inch-wide or 600-mm-wide tiles. The tile rail pieces do not actually attach to the T-grid struts. The ends of the rails sit over the T-grid strut. Normally, the tile supports the rails.

The tile rails are pre-punched at regular intervals with holes along their length. This allows the C-Ring to be positioned at any point along the rail. If the tile comes out or falls apart, the ends of the support rails fall onto the T-grid, which prevents the speaker assembly from falling.



#### **Warning!**

Always use all included support hardware when installing into suspended ceiling tiles to make sure the installation is secure.

#### **Sheetrock ceiling installations**

For sheetrock ceiling installations, use the C-Ring by itself to reinforce the ceiling material and to spread out the pressure from the speaker hold-down tabs.

To install the C-Ring:

1. Guide the C-Ring through the cut hole in the ceiling.
2. Place the C-Ring on the back side of the hole before inserting the speaker.

## **4.3**

### **Attaching wiring to the terminal connector**

To attach the wiring to the terminal connector:

1. Remove the terminal cover plate.
2. Remove the input connector.
3. Run the wire through the terminal clamp before attaching the connector.

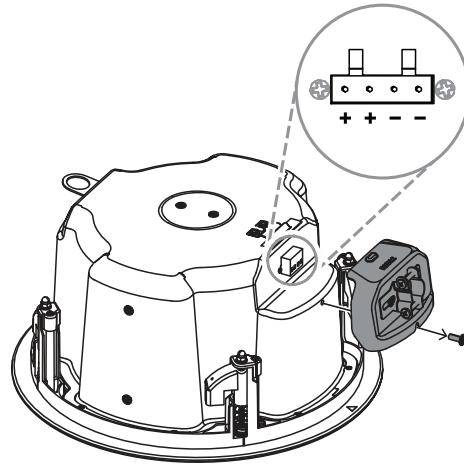
**Notice!**

The four terminals in the input connector are marked.

4. Insert the bare end of the wire into the appropriate connector terminals.
5. Screw down the hold-down screw until tight, using a small screwdriver.

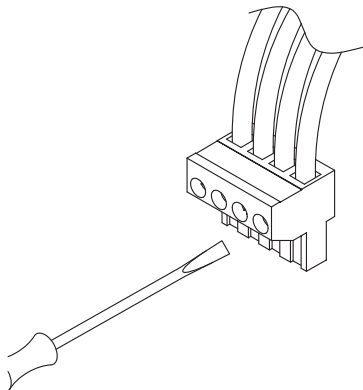

**Figure 4.2:** Tighten with screwdriver

**Wiring guidelines**

From left to right, Pin 1 is connected to Pin 2 and Pin 3 is connected to Pin 4 inside the speaker. Pins 1 and 4 are used as daisy-chain connections to other loudspeakers.

There are two possible layouts for wiring a group of speakers:

- Wiring in parallel
- Daisy-chaining

**Caution!**

Amplifier outputs may carry output voltages up to 100 V<sub>RMS</sub>. Touching uninsulated terminals or wiring may result in an unpleasant sensation. The external wiring of these terminals requires installation by an instructed person.

### Wiring in parallel

- ▶ Connect the wire pair of the subsequent speaker to pins 2 and 3.
- When one input connector is removed, subsequent speakers will remain connected.

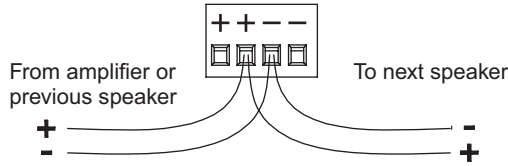

Figure 4.3: Parallel wiring

### Daisy-chaining

- ▶ Connect the wire pair of the subsequent speaker to pins 1 and 4.
- When one input connector is removed, subsequent speakers will also be disconnected.

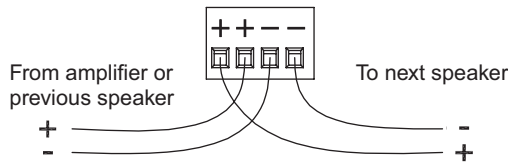

Figure 4.4: Daisy-chain wiring

### Plugging in the connector

To plug in the connector:

1. Plug the input connector into the socket in the speaker's terminal cup.
2. Tighten all screws to eliminate vibration.

## 4.4

### Securing the cable to the speaker

To secure the cable to the speaker:

1. Fully loosen the horizontal screw.
2. Fully loosen the strain relief screws.
3. Run the wires through the opening in the fitting.
4. Plug the input connector into the speaker's terminal block.
5. Tighten the strain relief fitting as appropriate to the cable used:
  - Plenum cable
  - Alternate conduit fitting

#### Plenum cable

1. Slide the wiring through the strain relief fitting on the terminal cover plate.
2. Follow instructions on *Attaching wiring to the terminal connector*, page 11.
3. Hold the strain relief fittings tight around the cable.
4. Tighten the strain relief screws first, then the horizontal screw.

In the cases of insulated speaker wire and plenum cable, it is often possible to provide acceptable strain relief force by simply tightening the strain relief screws onto the terminal cover plate.

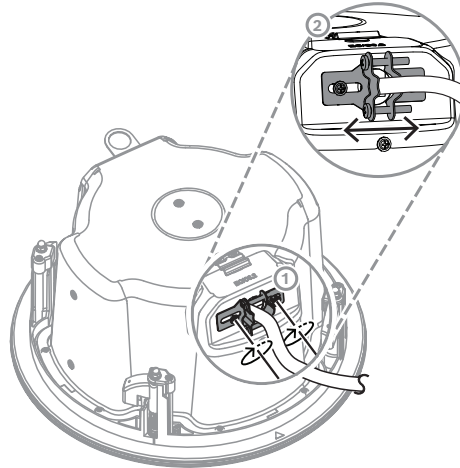

#### Alternate conduit fitting

If the installation uses flexible (BX) conduit, it is possible to use an alternate conduit fitting.



#### Notice!

Alternate fittings are available through most electrical suppliers.

1. Remove the existing fitting by unscrewing the two hold-down screws.  
This will expose a 7/8-inch (22 mm) knockout hole.
2. Install the alternate fitting.



#### Warning!

Always use a listed fitting in accordance with your area's building codes and regulations.

#### Refer to

- *Attaching wiring to the terminal connector, page 11*

## 4.5

### Reinstalling the terminal cover plate

To reinstall the terminal cover plate:

1. Thread the wire through the strain relief fitting on the terminal cover plate.
  2. Attach the wire to the input connector.
  3. Connect the input connector to the speaker.
  4. Guide the terminal cover plate into the terminal cover latch.
  5. Insert the terminal cover locking screw into the terminal cover plate.
  6. Tighten the terminal cover locking screw.
- Ensure the terminal cover plate is secure. Do not over tighten the terminal cover locking screw.

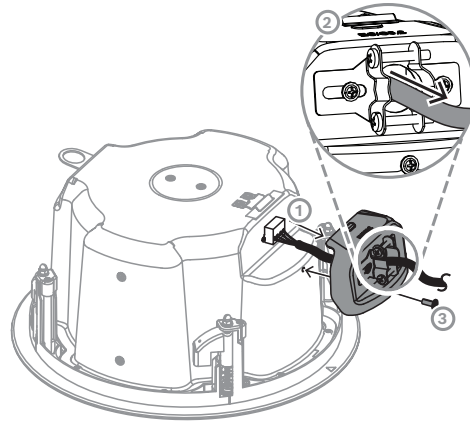

## 4.6

### Mounting the speaker into the ceiling

To mount the speaker into the ceiling:

1. Push the speaker into the ceiling hole until the front baffle is flush with the ceiling and you hear the mounting tabs click.

Make sure that the mounting tabs are loose before installing.

Once the speaker is in the ceiling, it will hold in place without additional help, allowing both hands to be removed from the speaker.

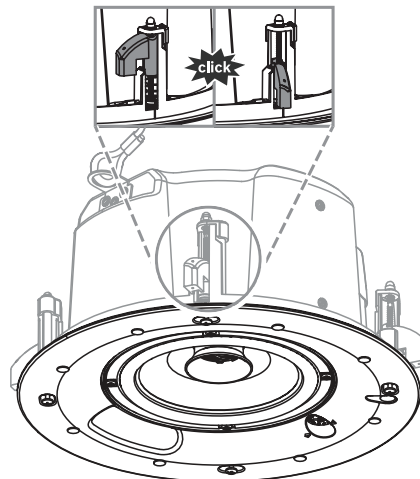

2. Tighten the mounting tabs by turning the screws clockwise until the speaker is tight against the ceiling surface.

Do not overtighten.

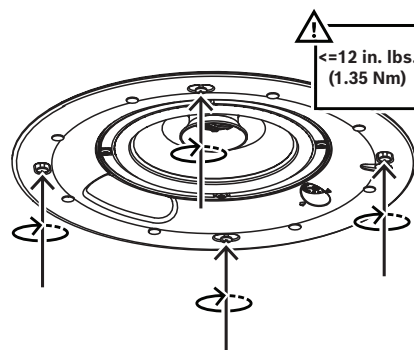

## 4.7 Adjusting the tap selector

The tap selector switch is located on the front baffle. Adjust the speaker to the appropriate tap setting before installing the grille. In some 70V/100V constant voltage installations it is advisable to leave the grilles off if final speaker audio level balance adjustments are to be made later. After the levels are adjusted the grilles can then be installed.

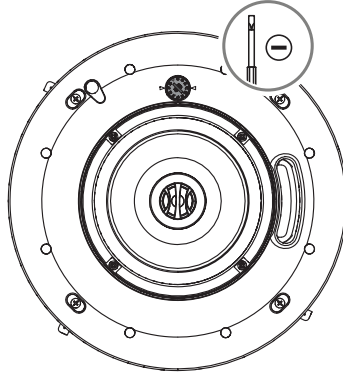

Transformer tap specifications

	EVID-C4.2-G2 EVID-C4.2LP-G2	EVID-C6.2-G2 EVID-C6.2LP-G2	EVID-C8.2-G2 EVID-C8.1S-G2	EVID-C8.2HC-G2
70 V		30 W 15 W 7.5 W 3.75 W 1.88 W	60 W 30 W 15 W 7.5 W 3.75 W	90 W 45 W 22.5 W 11.25 W 5.6 W
100 V		30 W 15 W 7.5 W 3.75 W	60 W 30 W 15 W 7.5 W	90 W 45 W 22.5 W 11.25 W

## 4.8 Attaching the grille



### Notice!

Grille safety tether

EVID-C-G2 Ceiling Loudspeakers grilles feature a safety tether to prevent the grille from falling if the grille is removed or comes loose after installation. The safety tether comes attached to the grille and must be installed on the speaker.

To attach the grille:

1. Push the fastener of the safety tether into the hole in the front of the baffle.
2. Push the grille against the baffle, making sure that it is centered and flat against the baffle. The magnetic grille will attach to the speaker.

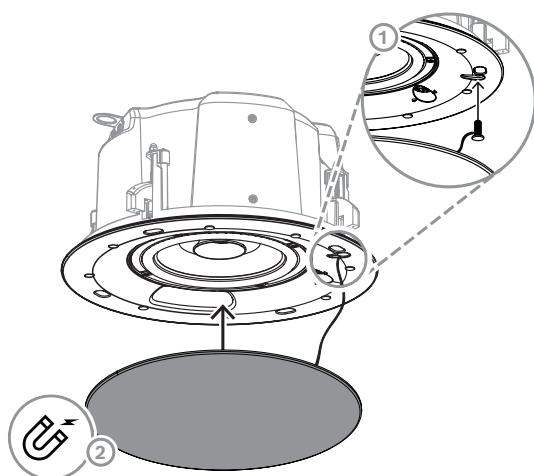

To remove the grille:

1. Grasp the edges of the grille with your fingertips.
2. Pull down.

## 5 Troubleshooting

Problem	Possible causes	Action
No output	Amplifier	<p>Ensure the amplifier channel is being fed an input signal (preferably via a signal input indicator on the amplifier).</p> <p>Verify the amplifier channel's volume is turned up.</p> <p>Connect the loudspeaker and cable, which had no output to another amplifier channel, ensuring an input signal is fed to the new amplifier channel. If you then get output, the problem was the amplifier channel. If not, then the problem is either the cable or the loudspeaker.</p>
	Loudspeaker cables(s)	Replace the cable(s) connecting the loudspeaker system and amplifier.
Questionable or intermittent output, such as crackling	Faulty connection	Check all cabling for proper connector contact. A bad connection can result in intermittent contact or dramatically increased resistance, which in turn can cause reduced output or noises unrelated to the signal.
	Improper power tap setting	Verify the power tap setting under the loudspeaker grille is appropriate for the installation and amplifier chosen.
Constant noise such as buzzing, hissing, or humming	A faulty electronic device in the signal chain	Loudspeakers cannot generate these sounds by themselves. You may have a faulty electronic device in the signal chain.
	Poor system grounding	Check and correct the system grounding, as required.
Poor low-frequency output	Out-of-polarity connection between multiple loudspeakers	When two loudspeakers are connected out of polarity (out of phase), the low frequencies cancel each other out. Try reversing the polarity of one of the loudspeakers either by turning around a dual-banana plug at the amplifier or by reversing the tip/sleeve leads on the jack. Whichever condition results in greater low-frequency output is the in-polarity condition.

If these suggestions do not solve your problem, contact your nearest Electro-Voice dealer or Electro-Voice distributor.

## 6 Technical data

EVID-C4.2-G2

Frequency range (-10 dB) (Hz) <sup>1</sup>	70 Hz – 20,000 Hz
Maximum SPL (continuous) (dB) <sup>2</sup>	106 dB
Maximum SPL (peak) (dB) <sup>2</sup>	112 dB
Sensitivity (1 W, 1 m) <sup>3</sup>	88 dB SPL 1 W, 1 m
Coverage angle conical (°)	130°
Power handling (continuous) (W) <sup>4</sup>	70 W
Power handling (peak) (W) <sup>4</sup>	280 W
Long term power handling (continuous) (W) <sup>5</sup>	50 W
Long term power handling (peak) (W) <sup>5</sup>	200 W
Nominal impedance (Ω) (Low Z)	8 Ω
Recommended high pass (Hz) <sup>6</sup>	70 Hz
Transformer taps 70 V line (W)	30 W; 15 W; 7.5 W; 3.75 W; 1.88 W
Transformer taps 100 V line (W)	30 W; 15 W; 7.5 W; 3.75 W
LF transducer size (in)	4 in
HF transducer size (in)	0.75 in
Material	Steel
Grille material	Powder coated steel
Connector type	4-pin Euroblock Input + Pass through
Wire size (AWG)	12AWG (maximum)
Wire diameter (mm <sup>2</sup> )	3.3 mm <sup>2</sup> (maximum)
Color	White; Customized colors
Color (RAL)	RAL 9003 Signal white
Mounting cutout (in)	7.20 in
Mounting cutout (mm)	183 mm
Dimensions (Ø x D) (in)	8.4 in x 6.40 in
Dimensions (Ø x D) (mm)	212 mm x 163.6 mm
Mounting depth (in)	6.2 in
Mounting depth (mm)	158 mm
Ceiling thickness (in)	0.5 in - 1.5 in
Ceiling thickness (mm)	12.5 mm - 38 mm
Weight (lb) <sup>7</sup>	5.9 lb
Weight (kg) <sup>7</sup>	2.7 kg

Shipping weight (lb) <sup>8</sup>	18.7 lb
Shipping weight (kg) <sup>8</sup>	8.5 kg
IP rating	IP34
Weatherization	Indoor
Operating temperature (°F)	32 °F – 122 °F
Operating temperature (°C)	0 °C – 50 °C
Safety agency ratings	UL 1480A, safe for use in air-handling spaces per UL 2043, CSA C22.2 No. 205 certified, IEC 62638

<sup>1</sup>Half-space (in-ceiling mounted)

<sup>2</sup>Calculated

<sup>3</sup>Half-space (1 W/1 m)

<sup>4</sup>Continuous pink noise (2 hours)

<sup>5</sup>Continuous pink noise (100 hours)

<sup>6</sup>24 dB/octave

<sup>7</sup>Single product

<sup>8</sup>Pair of products

## EVID-C4.2LP-G2

Frequency range (-10 dB) (Hz) <sup>1</sup>	80 Hz – 20,000 Hz
Maximum SPL (continuous) (dB) <sup>2</sup>	106 dB
Maximum SPL (peak) (dB) <sup>2</sup>	112 dB
Sensitivity (1 W, 1 m) <sup>3</sup>	88 dB SPL 1 W, 1 m
Coverage angle conical (°)	130°
Power handling (continuous) (W) <sup>4</sup>	70 W
Power handling (peak) (W) <sup>4</sup>	280 W
Long term power handling (continuous) (W) <sup>5</sup>	50 W
Long term power handling (peak) (W) <sup>5</sup>	200 W
Nominal impedance (Ω) (Low Z)	8 Ω
Recommended high pass (Hz) <sup>6</sup>	70 Hz
Transformer taps 70 V line (W)	30 W; 15 W; 7.5 W; 3.75 W; 1.88 W
Transformer taps 100 V line (W)	30 W; 15 W; 7.5 W; 3.75 W
LF transducer size (in)	4 in
HF transducer size (in)	0.75 in
Material	Steel
Grille material	Powder coated steel
Connector type	4-pin Euroblock Input + Pass through

Wire size (AWG)	12AWG (maximum)
Wire diameter (mm <sup>2</sup> )	3.3 mm <sup>2</sup> (maximum)
Color	White; Customized colors
Color (RAL)	RAL 9003 Signal white
Mounting cutout (in)	10.70 in
Mounting cutout (mm)	272 mm
Dimensions (Ø x D) (in)	11.9 in x 3.6 in
Dimensions (Ø x D) (mm)	302 mm x 91 mm
Mounting depth (in)	3.4 in
Mounting depth (mm)	86 mm
Ceiling thickness (in)	0.5 in - 1.5 in
Ceiling thickness (mm)	12.5 mm - 38 mm
Weight (lb) <sup>7</sup>	6.80 lb
Weight (kg) <sup>7</sup>	3.10 kg
Shipping weight (lb) <sup>8</sup>	22 lb
Shipping weight (kg) <sup>8</sup>	10 kg
IP rating	IP34
Weatherization	Indoor
Operating temperature (°F)	32 °F – 122 °F
Operating temperature (°C)	0 °C – 50 °C
Safety agency ratings	UL 1480A, safe for use in air-handling spaces per UL 2043, CSA C22.2 No. 205 certified, IEC 62638

<sup>1</sup>Half-space (in-ceiling mounted)

<sup>2</sup>Calculated

<sup>3</sup>Half-space (1 W/1 m)

<sup>4</sup>Continuous pink noise (2 hours)

<sup>5</sup>Continuous pink noise (100 hours)

<sup>6</sup>24 dB/octave

<sup>7</sup>Single product

<sup>8</sup>Pair of products

## EVID-C6.2-G2

Frequency range (-10 dB) (Hz) <sup>1</sup>	65 Hz – 20,000 Hz
Maximum SPL (continuous) (dB) <sup>2</sup>	109 dB
Maximum SPL (peak) (dB) <sup>2</sup>	115 dB
Sensitivity (1 W, 1 m) <sup>3</sup>	90 dB SPL 1 W, 1 m

Coverage angle conical (°)	110°
Power handling (continuous) (W) <sup>4</sup>	80 W
Power handling (peak) (W) <sup>4</sup>	320 W
Long term power handling (continuous) (W) <sup>5</sup>	70 W
Long term power handling (peak) (W) <sup>5</sup>	280 W
Nominal impedance (Ω) (Low Z)	8 Ω
Recommended high pass (Hz) <sup>6</sup>	60 Hz
Transformer taps 70 V line (W)	30 W; 15 W; 7.5 W; 3.75 W; 1.88 W
Transformer taps 100 V line (W)	30 W; 15 W; 7.5 W; 3.75 W
LF transducer size (in)	6 in
HF transducer size (in)	1 in
Material	Steel
Grille material	Powder coated steel
Connector type	4-pin Euroblock
Wire size (AWG)	12AWG (maximum)
Wire diameter (mm <sup>2</sup> )	3.3 mm <sup>2</sup> (maximum)
Color	White; Customized colors
Color (RAL)	RAL 9003 Signal white
Mounting cutout (in)	10.70 in
Mounting cutout (mm)	272 mm
Dimensions (Ø x D) (in)	11.9 in x 6 in
Dimensions (Ø x D) (mm)	302 mm x 153.8 mm
Mounting depth (in)	5.9 in
Mounting depth (mm)	149 mm
Ceiling thickness (in)	0.5 in - 1.5 in
Ceiling thickness (mm)	12.5 mm - 38 mm
Weight (lb) <sup>7</sup>	9 lb
Weight (kg) <sup>7</sup>	4.10 kg
Shipping weight (lb) <sup>8</sup>	27 lb
Shipping weight (kg) <sup>8</sup>	12.20 kg
IP rating	IP34
Weatherization	Indoor
Operating temperature (°F)	32 °F – 122 °F
Operating temperature (°C)	0 °C – 50 °C

Safety agency ratings	UL 1480A, safe for use in air-handling spaces per UL 2043, CSA C22.2 No. 205 certified, IEC 62638
-----------------------	---

<sup>1</sup>Half-space (in-ceiling mounted)

<sup>2</sup>Calculated

<sup>3</sup>Half-space (1 W/1 m)

<sup>4</sup>Continuous pink noise (2 hours)

<sup>5</sup>Continuous pink noise (100 hours)

<sup>6</sup>24 dB/octave

<sup>7</sup>Single product

<sup>8</sup>Pair of products

## EVID-C6.2LP-G2

Frequency range (-10 dB) (Hz) <sup>1</sup>	60 Hz – 20,000 Hz
Maximum SPL (continuous) (dB) <sup>2</sup>	109 dB
Maximum SPL (peak) (dB) <sup>2</sup>	115 dB
Sensitivity (1 W, 1 m) <sup>3</sup>	90 dB SPL 1 W, 1 m
Coverage angle conical (°)	110°
Power handling (continuous) (W) <sup>4</sup>	80 W
Power handling (peak) (W) <sup>4</sup>	320 W
Long term power handling (continuous) (W) <sup>5</sup>	70 W
Long term power handling (peak) (W) <sup>5</sup>	280 W
Nominal impedance (Ω) (Low Z)	8 Ω
Recommended high pass (Hz) <sup>6</sup>	60 Hz
Transformer taps 70 V line (W)	30 W; 15 W; 7.5 W; 3.75 W; 1.88 W
Transformer taps 100 V line (W)	30 W; 15 W; 7.5 W; 3.75 W
LF transducer size (in)	6 in
HF transducer size (in)	1 in
Material	Steel
Grille material	Powder coated steel
Connector type	4-pin Euroblock Input + Pass through
Wire size (AWG)	12AWG (maximum)
Wire diameter (mm <sup>2</sup> )	3.3 mm <sup>2</sup> (maximum)
Color	White; Customized colors
Color (RAL)	RAL 9003 Signal white
Mounting cutout (in)	12.70 in
Mounting cutout (mm)	322 mm

Dimensions (Ø x D) (in)	13.9 in x 5.3 in
Dimensions (Ø x D) (mm)	353 mm x 133.1 mm
Mounting depth (in)	4.8 in
Mounting depth (mm)	122 mm
Ceiling thickness (in)	0.5 in - 1.5 in
Ceiling thickness (mm)	12.5 mm - 38 mm
Weight (lb) <sup>7</sup>	9.90 lb
Weight (kg) <sup>7</sup>	4.50 kg
Shipping weight (lb) <sup>8</sup>	31 lb
Shipping weight (kg) <sup>8</sup>	14 kg
IP rating	IP34
Weatherization	Indoor
Operating temperature (°F)	32 °F – 122 °F
Operating temperature (°C)	0 °C – 50 °C
Safety agency ratings	UL 1480A, safe for use in air-handling spaces per UL 2043, CSA C22.2 No. 205 certified, IEC 62638

<sup>1</sup>Half-space (in-ceiling mounted)

<sup>2</sup>Calculated

<sup>3</sup>Half-space (1 W/1 m)

<sup>4</sup>Continuous pink noise (2 hours)

<sup>5</sup>Continuous pink noise (100 hours)

<sup>6</sup>24 dB/octave

<sup>7</sup>Single product

<sup>8</sup>Pair of products

## EVID-C8.2-G2

Frequency range (-10 dB) (Hz) <sup>1</sup>	60 Hz – 20,000 Hz
Maximum SPL (continuous) (dB) <sup>2</sup>	110 dB
Maximum SPL (peak) (dB) <sup>2</sup>	116 dB
Sensitivity (1 W, 1 m) <sup>3</sup>	90 dB SPL 1 W, 1 m
Coverage angle conical (°)	90°
Power handling (continuous) (W) <sup>4</sup>	90 W
Power handling (peak) (W) <sup>4</sup>	360 W
Long term power handling (continuous) (W) <sup>5</sup>	75 W
Long term power handling (peak) (W) <sup>5</sup>	300 W
Nominal impedance (Ω) (Low Z)	8 Ω

Recommended high pass (Hz) <sup>6</sup>	50 Hz
Transformer taps 70 V line (W)	60 W; 30 W; 15 W; 7.5 W; 3.75 W
Transformer taps 100 V line (W)	60 W; 30 W; 15 W; 7.5 W
LF transducer size (in)	8 in
HF transducer size (in)	1 in
Material	Steel
Grille material	Powder coated steel
Connector type	4-pin Euroblock Input + Pass through
Wire size (AWG)	12AWG (maximum)
Wire diameter (mm <sup>2</sup> )	3.3 mm <sup>2</sup> (maximum)
Color	White; Customized colors
Color (RAL)	RAL 9003 Signal white
Mounting cutout (in)	10.70 in
Mounting cutout (mm)	272 mm
Dimensions (Ø x D) (in)	11.9 in x 9.8 in
Dimensions (Ø x D) (mm)	302 mm x 249.2 mm
Mounting depth (in)	9.6 in
Mounting depth (mm)	244 mm
Ceiling thickness (in)	0.5 in - 1.5 in
Ceiling thickness (mm)	12.5 mm - 38 mm
Weight (lb) <sup>7</sup>	15.4 lb
Weight (kg) <sup>7</sup>	7 kg
Shipping weight (lb) <sup>8</sup>	36.4 lb
Shipping weight (kg) <sup>8</sup>	16.5 kg
IP rating	IP34
Weatherization	Indoor
Operating temperature (°F)	32 °F – 122 °F
Operating temperature (°C)	0 °C – 50 °C
Safety agency ratings	UL 1480A, safe for use in air-handling spaces per UL 2043, CSA C22.2 No. 205 certified, IEC 62638

<sup>1</sup>Half-space (in-ceiling mounted)

<sup>2</sup>Calculated

<sup>3</sup>Half-space (1 W/1 m)

<sup>4</sup>Continuous pink noise (2 hours)<sup>5</sup>Continuous pink noise (100 hours)<sup>6</sup>24 dB/octave<sup>7</sup>Single product<sup>8</sup>Pair of products

## EVID-C8.2HC-G2

Frequency range (-10 dB) (Hz) <sup>1</sup>	60 Hz – 20,000 Hz
Maximum SPL (continuous) (dB) <sup>2</sup>	118 dB
Maximum SPL (peak) (dB) <sup>2</sup>	124 dB
Sensitivity (1 W, 1 m) <sup>3</sup>	95 dB SPL 1 W, 1 m
Coverage angle conical (°)	75°
Power handling (continuous) (W) <sup>4</sup>	180 W
Power handling (peak) (W) <sup>4</sup>	720 W
Long term power handling (continuous) (W) <sup>5</sup>	150 W
Long term power handling (peak) (W) <sup>5</sup>	600 W
Nominal impedance (Ω) (Low Z)	8 Ω
Recommended high pass (Hz) <sup>6</sup>	50 Hz
Transformer taps 70 V line (W)	90 W; 45 W; 22.5 W; 11.25 W; 5.6 W
Transformer taps 100 V line (W)	90 W; 45 W; 22.5 W; 11.25 W
LF transducer size (in)	8 in
HF transducer size (in)	1 in
Material	Steel
Grille material	Powder coated steel
Connector type	4-pin Euroblock Input + Pass through
Wire size (AWG)	12AWG (maximum)
Wire diameter (mm <sup>2</sup> )	3.3 mm <sup>2</sup> (maximum)
Color	White; Customized colors
Color (RAL)	RAL 9003 Signal white
Mounting cutout (in)	12.70 in
Mounting cutout (mm)	322 mm
Dimensions (Ø x D) (in)	13.9 in x 9.9 in
Dimensions (Ø x D) (mm)	353 mm x 250.7 mm
Mounting depth (in)	9.5 in
Mounting depth (mm)	240 mm
Ceiling thickness (in)	0.5 in - 1.5 in

Ceiling thickness (mm)	12.5 mm - 38 mm
Weight (lb) <sup>7</sup>	21.4 lb
Weight (kg) <sup>7</sup>	9.7 kg
Shipping weight (lb) <sup>8</sup>	50.7 lb
Shipping weight (kg) <sup>8</sup>	23 kg
IP rating	IP34
Weatherization	Indoor
Operating temperature (°F)	32 °F – 122 °F
Operating temperature (°C)	0 °C – 50 °C
Safety agency ratings	UL 1480A, safe for use in air-handling spaces per UL 2043, CSA C22.2 No. 205 certified, IEC 62638

<sup>1</sup>Half-space (in-ceiling mounted)

<sup>2</sup>Calculated

<sup>3</sup>Half-space (1 W/1 m)

<sup>4</sup>Continuous pink noise (2 hours)

<sup>5</sup>Continuous pink noise (100 hours)

<sup>6</sup>24 dB/octave

<sup>7</sup>Single product

<sup>8</sup>Pair of products

## EVID-C8.1S-G2

Frequency range (-10 dB) (Hz) <sup>1</sup>	45 Hz – 380 Hz
Maximum SPL (continuous) (dB) <sup>2</sup>	113 dB
Maximum SPL (peak) (dB) <sup>2</sup>	119 dB
Sensitivity (1 W, 1 m) <sup>3</sup>	90 dB SPL 1 W, 1 m
Coverage angle omnidirectional (°)	360°
Power handling (continuous) (W) <sup>4</sup>	180 W
Power handling (peak) (W) <sup>4</sup>	720 W
Long term power handling (continuous) (W) <sup>5</sup>	150 W
Long term power handling (peak) (W) <sup>5</sup>	600 W
Nominal impedance (Ω) (Low Z)	8 Ω
Transformer taps 70 V line (W) <sup>6</sup>	60 W; 30 W; 15 W; 7.5 W; 3.75 W
Transformer taps 100 V line (W) <sup>6</sup>	60 W; 30 W; 15 W; 7.5 W
LF transducer size (in)	8 in
Material	Steel
Grille material	Powder coated steel

Connector type	4-pin Euroblock Input + Pass through
Wire size (AWG)	12AWG (maximum)
Wire diameter (mm <sup>2</sup> )	3.3 mm <sup>2</sup> (maximum)
Color	White; Customized colors
Color (RAL)	RAL 9003 Signal white
Mounting cutout (in)	12.70 in
Mounting cutout (mm)	322 mm
Dimensions (Ø x D) (in)	13.9 in x 9.9 in
Dimensions (Ø x D) (mm)	353 mm x 250.7 mm
Mounting depth (in)	9.5 in
Mounting depth (mm)	240 mm
Ceiling thickness (in)	0.5 in - 1.5 in
Ceiling thickness (mm)	12.5 mm - 38 mm
Weight (lb) <sup>7</sup>	16 lb
Weight (kg) <sup>7</sup>	7.25 kg
Shipping weight (lb) <sup>8</sup>	40 lb
Shipping weight (kg) <sup>8</sup>	18.10 kg
IP rating	IP34
Weatherization	Indoor
Operating temperature (°F)	32 °F – 122 °F
Operating temperature (°C)	0 °C – 50 °C
Safety agency ratings	UL 1480A, safe for use in air-handling spaces per UL 2043, CSA C22.2 No. 205 certified, IEC 62638

<sup>1</sup>Half-space (in-ceiling mounted) - UL tested (20 Hz to 20 kHz)

<sup>2</sup>Calculated

<sup>3</sup>Half-space (1 W/1 m)

<sup>4</sup>Continuous pink noise (2 hours)

<sup>5</sup>Continuous pink noise (100 hours)

<sup>6</sup>Continuous pink noise (20 Hz to 20 kHz)

<sup>7</sup>Single product

<sup>8</sup>Pair of products

## 7 Appendices

### 7.1 Painting the speaker grille

If the speaker is installed in an area where the interior design requires a color match, our bezel-less design makes this painting process very simple.

To paint the speaker grille:

- ▶ Simply remove the grille and paint it using an enamel-based spray paint.

#### Painting Process

1. Remove the grille from the speaker.



#### Warning!

Do not use gasoline, kerosene, acetone, or other harsh solvents or chemicals, and do not use abrasive products such as sandpaper or steel wood.

2. Spray the grille at a 45-degree angle, applying a single light coat moving from left to right, and then a secondary coat from right to left.
3. Let the paint dry and, if needed, repeat the step above.

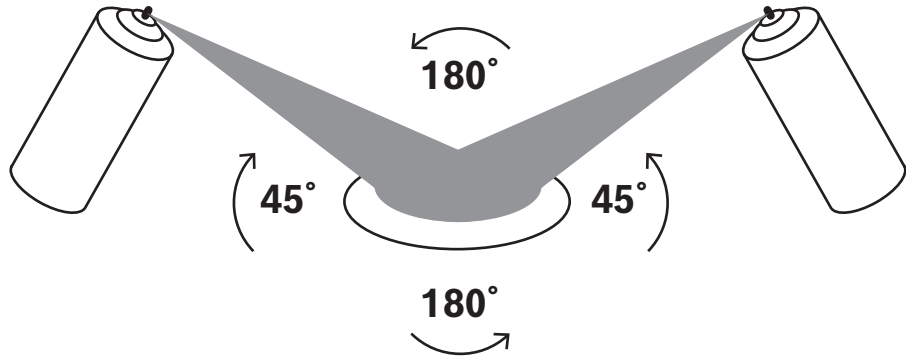

Figure 7.1: Spray painting angles

4. Reinstall the grille on the speaker.

### 7.2 Protecting the speaker grille while painting the room

To protect the speaker grille from paint:

1. Remove the grille from the speaker.
2. Cover the grille with the paint cover.
3. Reinstall the grille with the cover.

After painting the room:

1. Remove the grille from the speaker.
2. Remove the paint cover from the grille.
3. Reinstall the grille on the speaker.

## 7.3 System design guide

### 7.3.1 Selecting and positioning ceiling loudspeakers

Several key criteria determine the type and quantity of ceiling speakers to employ in a job. Specific EVID Ceiling Series models accommodate each job, depending on how these criteria are specified.

- Room size
- Coverage density desired
- Coverage angle specification of the speaker
- Ceiling height
- Audio program material being played

This information, and the free design program downloadable from [www.electrovoice.com](http://www.electrovoice.com), will help you optimize your EVID design.

In the traditional approach to overhead distributed systems, loudspeakers are placed in a grid whose dimensions are dictated by the room height and the directivity of the speaker elements.

Two basic placement patterns prevail:

- Square spacing
- Hexagonal (or crisscross) spacing

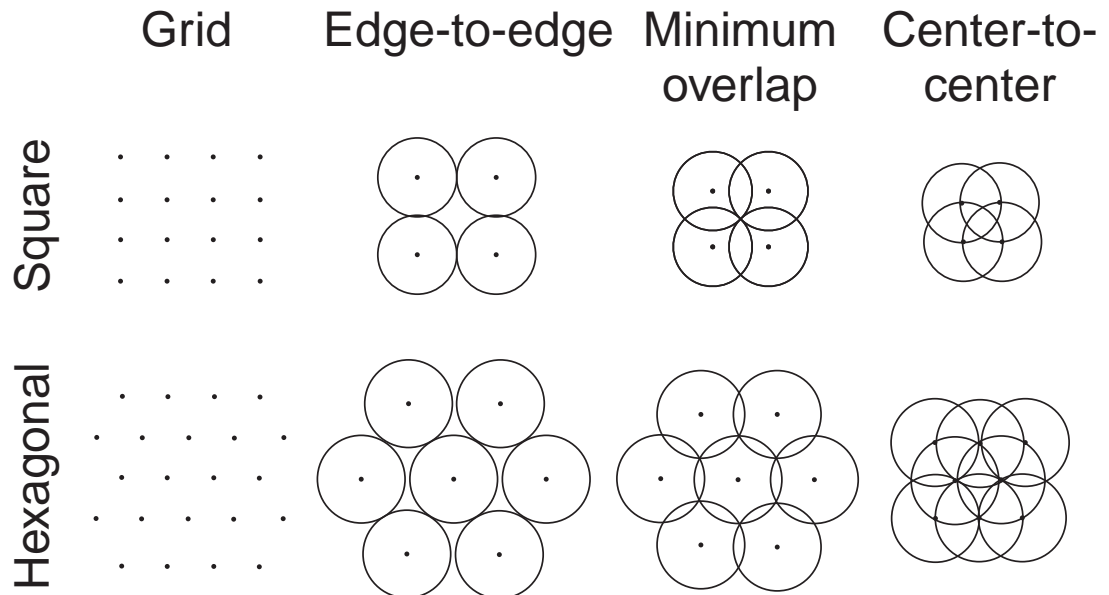

Figure 7.2: Coverage patterns

In addition to the spacing pattern, the designer must choose between three coverage density types:

- Edge-to-edge
- Minimum overlap
- Center-to-center

The greater the overlap, the more uniform the coverage. The , page 31 illustration shows these various layout patterns.

#### Refer to

- , page 31

### 7.3.2 Ceiling systems: size vs. coverage

In the past, system designers usually specified 8-inch cone loudspeakers for distributed overhead systems, at least in part because they represented the traditional choice. EVID-G2 systems, however, allow for far more flexible options.

In many cases, you can achieve excellent results — at a significant savings — by using 4-inch transducers. This is especially true in jobs that do not require extended low-end response or high SPL levels. Four-inch transducers, such as those used in the EVID-C4.2-G2, offer wider dispersion to allow for fewer speakers to be employed in the job. For example, due to its smaller cone diameter, the EVID-C4.2-G2 exhibits significantly wider dispersion (130 degrees) than the EVID-C8.2-G2 (110 degrees) at the -6 dB points.

The effect of this characteristic on an overhead system is indicated in the , page 31 illustration. In replacement applications where existing speaker positions are used, the EVID-C4.2-G2 (shown in angle A) offers greater overlap and, thus, more uniform coverage than an older conventional 8-inch unit (shown in angle B). When specifying a new system, you can take advantage of the EVID-C4.2-G2's wider dispersion to decrease the number of speakers required to cover a given area. This will result in even greater savings.

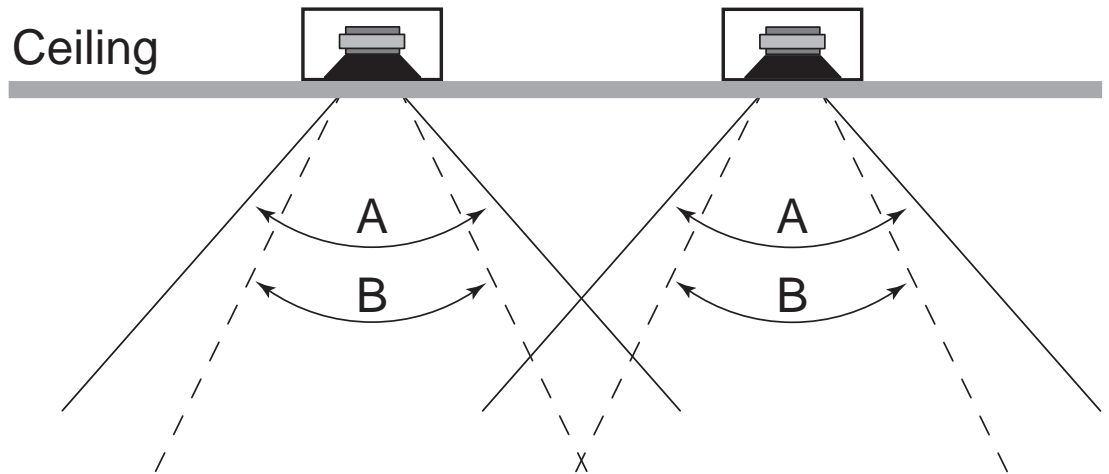

**Figure 7.3:** Size vs coverage

Of course, the EVID-C4.2-G2 is somewhat less sensitive than the 8-inch EVID-C8.2-G2. The difference is - 5 dB. The EVID-C4.2-G2 will also have slightly reduced low-frequency capabilities below 65 Hz. However, neither of these factors is a significant problem in many distributed systems. The EVID-C4.2-G2 is conservatively rated to handle 80 watts of continuous power equal to or greater than most other brands of 8-inch units, so its continuous SPL output will be more than adequate. Moreover, its low-frequency output can easily be augmented with the addition of the EVID-C8.1S-G2 subwoofer. For these reasons, the EVID-C4.2-G2 represents a great way for you to provide good audio coverage while maintaining a competitive edge in price quotes in installations that do not need the extended performance of the larger models.

### Reverberant Rooms and High Ceilings

Situations arise, however, in which controlled coverage is more desirable than broad dispersion. Very large live spaces such as gymnasiums, convention centers, shopping mall atriums, and the like all benefit from more controlled sound projection. In such installations, the EVID-C8.2HC-G2 is the best choice. Its 75-degree coverage pattern above 1 kHz provides more intelligibility in large, acoustically live spaces. It also has a high 93 dB sensitivity rating for optimum efficiency.

### SPL requirements: how loud?

The EVID-C8.2-G2 is a great speaker to use when higher SPL is required. The fidelity and bandwidth of the unit is substantial and is ideal for applications requiring high quality foreground music reproduction. The EVID-C8.2-G2 has substantial low frequency energy down below 60 Hz. This is more than sufficient for most applications.

**Layout: how many?**

The **Coverage diameter by ceiling height** table shows the effective coverage diameter of the EVID-G2 models assuming a 4-foot listening plane height. Using these figures you can lay out a coverage pattern for the job after deciding the overlap criteria.

Model	Ceiling height				
	8'	12'	16'	20'	24'
EVID-C4.2-G2 EVID-C4.2LP-G2	17'	34'	51'	69'	86'
EVID-C6.2-G2 EVID-C6.2LP-G2	11'	23'	34'	46'	57'
EVID-C8.2-G2	8'	16'	24'	32'	40'
EVID-C8.2HC-G2	6'	12'	18'	25'	31'

**Table 7.1:** Coverage diameter by ceiling height<sup>1</sup>

<sup>1</sup> Coverage calculated at 4-foot listening height

**Refer to**

– , page 31

**7.3.3****Use of subwoofers**

The EVID-C8.1S-G2 subwoofer can add considerable low frequency performance to any EVID-G2 installation. It is important to note that the EVID-C8.1S-G2 subwoofer depends on the ceiling and walls to properly load itself and to reinforce its bass output. Correct positioning is important to get maximum impact.

In smaller rooms when a single EVID-C8.1S-G2 is used, a center or near-center position is best. This gives the most even coverage. For larger rooms where more than one EVID-C8.1S-G2 are employed, the added effect of the room's walls can be used. In such a space, position the subwoofers evenly throughout the room and a few feet from the wall or corners. The added loading of the walls will enhance the response in these larger areas.







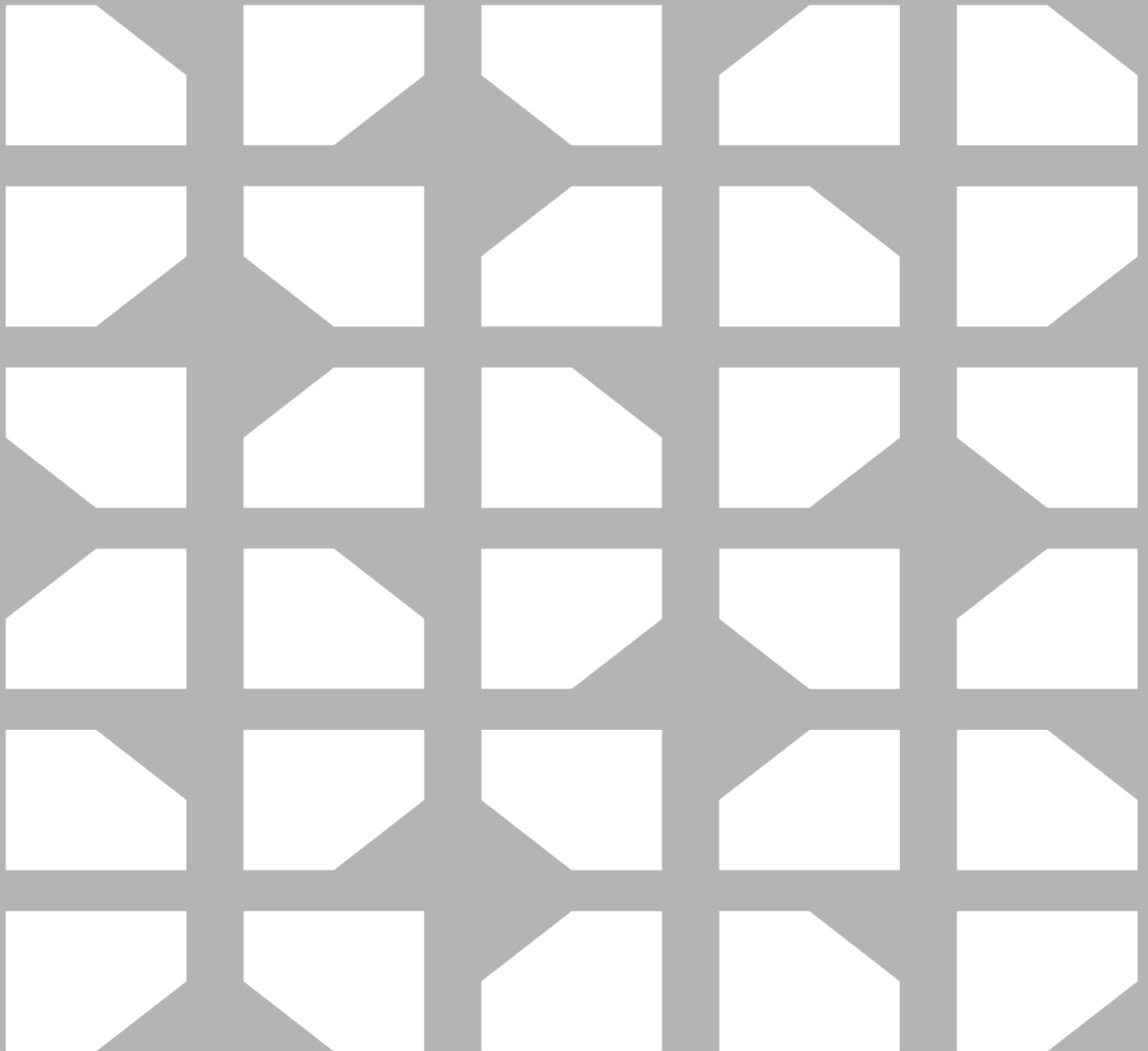

**Bosch Security Systems, LLC**

130 Perinton Parkway

Fairport, NY 14450

USA

[www.electrovoice.com](http://www.electrovoice.com)

© Bosch Security Systems, LLC, 2025

**EU importer:**

**EVI Audio GmbH**

Sachsenring 60

94315 Straubing

Germany

© EVI Audio GmbH, 2025