

# EVH-1152S/94 Arrayable point-source coaxial horn-loaded loudspeaker

- High-performance horn-loaded arrayable coaxial point-source loudspeaker
- Rotatable mid- and high-frequency constant directivity waveguides
- 105 dB sensitivity, 138 dB maximum SPL; System rating: 500W Continuous (2000W Peak)
- Partially-weatherized PI and fully-weatherized FG versions available with gland nut and stainless-steel grille rated IEC 60529 IP55

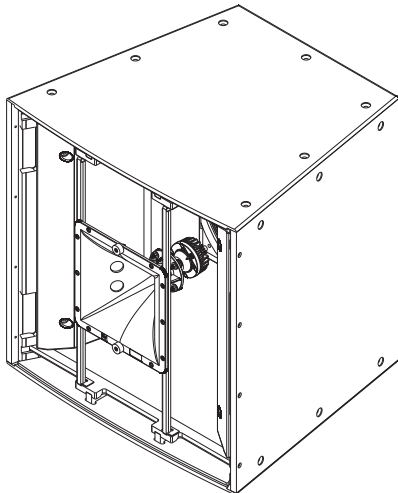

The Electro-Voice EVH-1152S/94 is a high power, 2-way Horn loaded coaxial loudspeaker system that can be used in a variety of applications where excellent quality sound reinforcement, wide bandwidth directivity control, and high efficiency are required in a compact package.

The EVH-1152S/94 utilizes an ND2B and an SMX2151. The ND2B is a high output 2" titanium compression driver, coupled to a rotatable 12" x 12" Constant Directivity 90° x 40° waveguide. The new SMX2151 is a high output, low distortion 15" woofer. Developed by EV engineering the motor, suspension, and electrical characteristics of the woofer are optimized to maximize efficiency and minimize distortion. The passive crossover network employs 24 dB/octave slopes for a smooth response in the vocal range, linear off-axis response, and features a comprehensive protection circuit for long term reliability. This combination of technologies results in a smooth response to 16 kHz and excellent pattern control down to 500Hz.

The EVH-1152S/94 features make it ideal for any fixed install application. The trapezoidal enclosure is constructed out of 13 ply, 18mm birch, and coated with EVCoat™ for maximum protection from the elements. PI weather resistant models uses a stainless steel grill grille backed with multiple material layers to prevent weather or humidity ingress. The EVH family of models employ an intelligent combination of superior acoustic design and rigging which allow for vertical and horizontal arrays to be built using any combination of loudspeakers from the entire EVF & EVH Series. 28 suspension points for use with rated eyebolts or EV -I array hardware provide low cost, simple rigging solutions. With 5 horn patterns to

choose from and an assortment of low frequency and subwoofer loudspeakers, EVH provides you the tools to easily design a custom tailored solution, no matter what the application or budget. The innovative input panel can be customized to one of three input choices, including a phoenix style connector (included in all standard models), dual NL4 type connectors, or a gland nut cover plate (for weatherizing applications). An externally accessible jumper selects passive or active operation. An available 70.7/100 Volt transformer kit can be easily installed for use in distributed systems.

## Technical specifications

Frequency response <sup>1</sup> (-3 dB):	60 Hz - 15 kHz
Frequency range <sup>1</sup> (-10 dB):	50 Hz - 16 kHz
Rec. hipass frequency:	60 Hz
Axial sensitivity:	105 dB (1W/1m)
Max. calculated SPL:	138 dB
Horizontal coverage:	90° (or 40°)
Vertical coverage:	40° (or 90°)
Power handling:	500W continuous, 2000W peak
LF transducer:	SMX2151, 15 in (381mm) driver
HF transducer:	ND2B, 2 in (51mm) diaphragm compression driver
Crossover frequency:	1300 Hz
Nominal impedance:	8 Ohms
Minimum impedance:	6.0 Ohms

Connectors:	(2) 4 Contact 10 AWG (2.6mm) Phoenix/Euroblock style screw terminals PI version - Gland nut with included input panel cover
Enclosure material:	13 Ply weather resistant birch
Grille:	16 GA Galvanneal, powdercoat, with rotatable logo PI version -Stainless steel with hydrophobic cloth
Suspension:	(28) M10 Threaded points
Dimensions (H x W x D):	30.26" x 30.26" x 26.77" (768.6mm x 768.6mm x 680.1mm)
Net weight:	143 lbs (64.9 kg)
Shipping weight:	158 lbs (71.8 kg)

<sup>1</sup> Half space measurement

**Frequency Response and Impedance:**

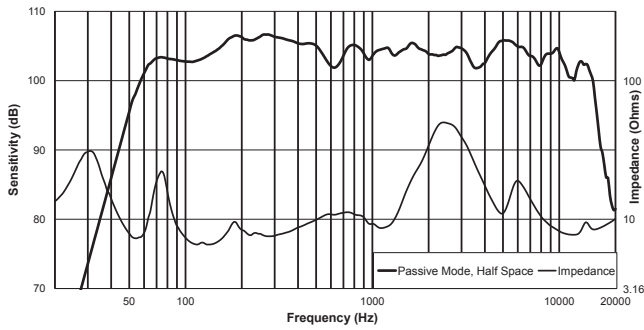

**Horizontal Off-Axis Frequency Response:**

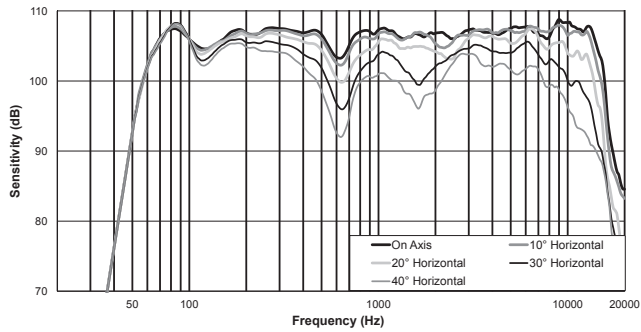

**Vertical Off-Axis Frequency Response:**

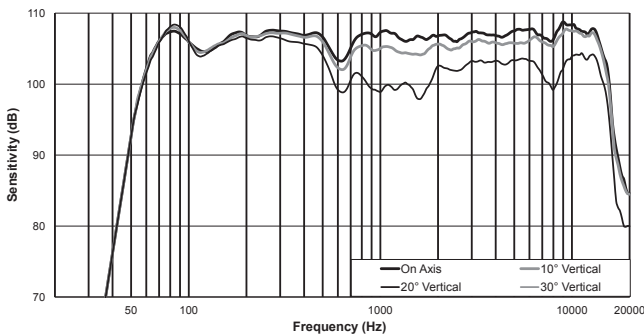

**Beamwidth:**

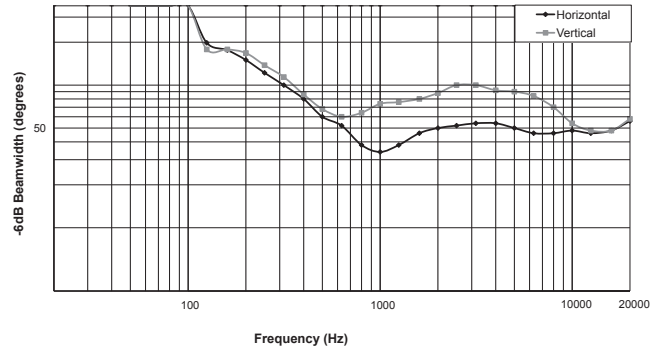

**Directivity:**

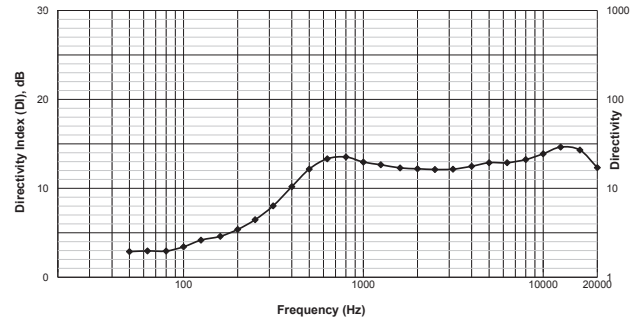

**Block Diagram (Biamp):**

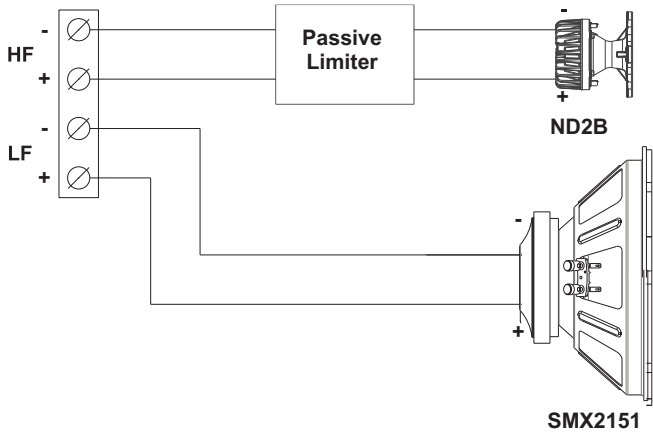

**Block Diagram (Passive):**

Standard shipping configuration

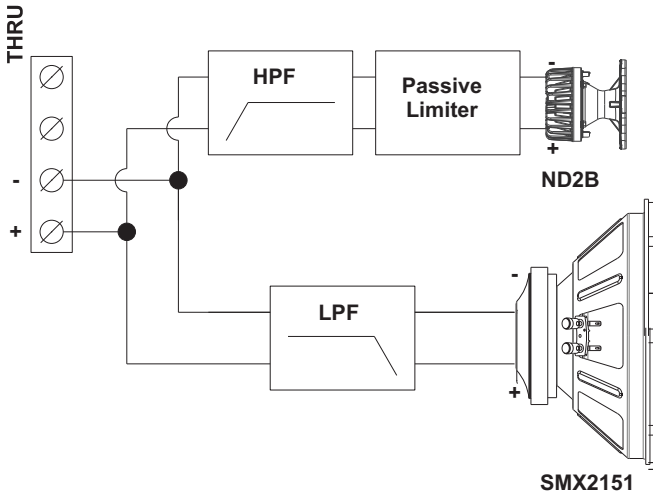

**Horizontal and Vertical Polar Response:**

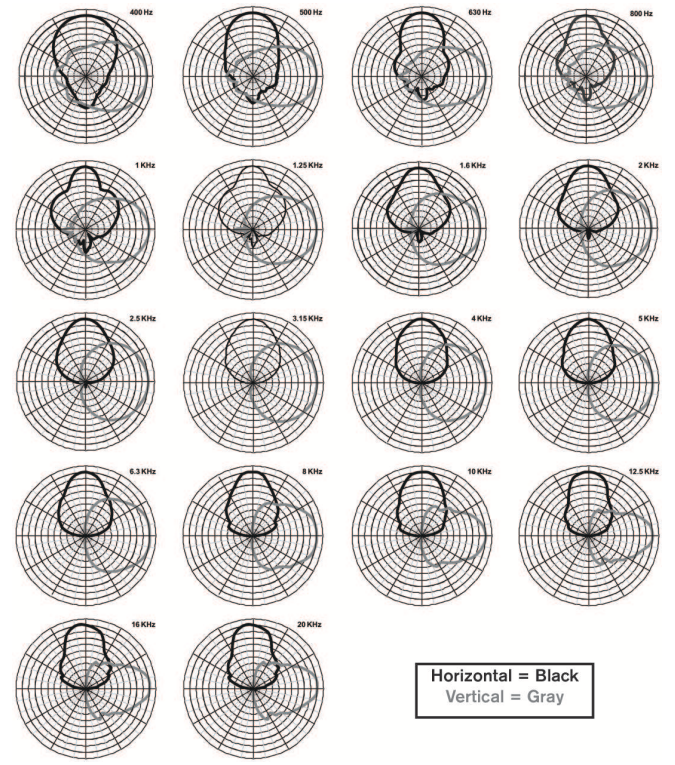

**Dimension Drawing:**

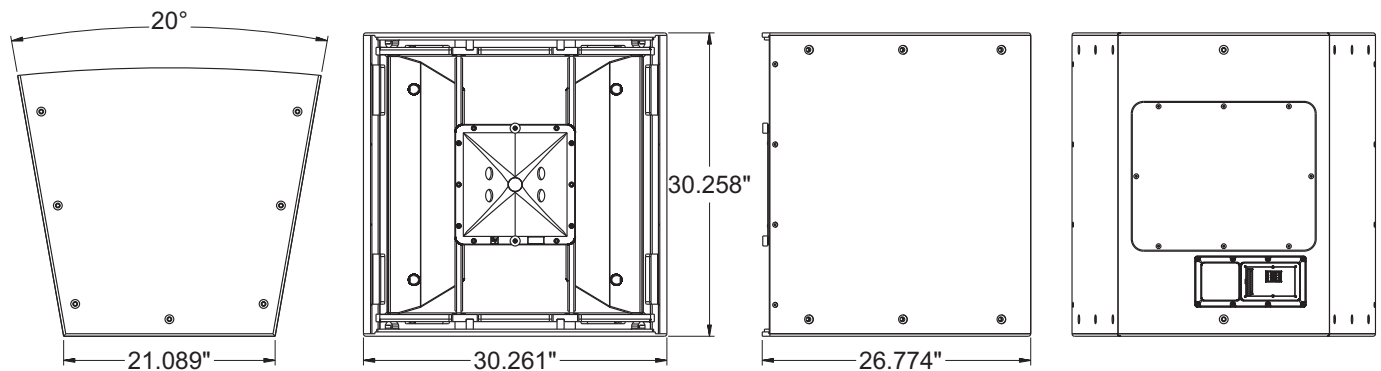

**i Notice**  
 This Electro-Voice loudspeaker should be suspended overhead only in accordance with the procedures and limitations specified in the User's Manual and possible manual update notices. This system should be suspended with certified rigging hardware by an authorized rigging professional and in compliance with local, state, and federal overhead suspension ordinances.

**Compatible System Solutions:**

EVF-1121S	12" Bass Element
EVF-1151S	15" Bass Element
EVF-1181S	18" Bass Element
EVH-1152S/6	Coaxial 60° x 40° Coverage
4	
EVH-1152S/6	Coaxial 60° x 60° Coverage
6	
EVH-1152S/9	Coaxial 90° x 60° Coverage
6	
EVH-1152S/9	Coaxial 90° x 90° Coverage
9	
CPS2.9	120V Power Amplifier, 2 x 900W
CPS2.12	120V Power Amplifier, 2 x 1200W
CPS4.5	120V Power Amplifier, 4 x 500W
CPS4.10	120V Power Amplifier, 4 x 1000W

**Ordering information**

**EVH1152S94BLB 15" speaker 90x40 indoor black**  
 15" / 2-way Full-range Systems; SMX woofer & ND2B driver - 500 W cont.; 90° x 40°, EVCoat, black  
 Order number **EVH1152S94BLB | F.01U.272.778**

**EVH1152S94WLB 15" speaker 90x40 indoor white**  
 15" / 2-way Full-range Systems; SMX woofer & ND2B driver - 500 W cont.; 90° x 40°, EVCoat, white  
 Order number **EVH1152S94WLB | F.01U.272.779**

**EVH1152S94PBLB 15" speaker 90x40 weatherized black**  
 15" / 2-way Full-range Systems; SMX woofer & ND2B driver - 500 W cont.; 90° x 40°, EVCoat, PI-weatherized, black  
 Order number **EVH1152S94PBLB | F.01U.272.780**

**EVH1152S94PWL B 15" speaker 90x40 weathrized white**  
 15" / 2-way Full-range Systems; SMX woofer & ND2B driver - 500 W cont.; 90° x 40°, EVCoat, PI-weatherized, white  
 Order number **EVH1152S94PWL B | F.01U.272.781**

**EVH1152S94-FBLB 15" speaker 90x40 fiberglass black**  
 15" / 2-way Full-range Systems; SMX woofer & ND2B driver - 500 W cont.; 90° x 40°, EVCoat, fiberglass, black  
 Order number **EVH1152S94-FBLB | F.01U.272.967**

**EVH1152S94-FWL B 15" speaker 90x40 fiberglass white**  
 15" / 2-way Full-range Systems; SMX woofer & ND2B driver - 500 W cont.; 90° x 40°, EVCoat, fiberglass, white  
 Order number **EVH1152S94-FWL B | F.01U.272.968**

**EVH-1152S/94-BLKE 15" speaker 90x40 indoor black**  
 15" / 2-way Full-range Systems; SMX woofer & ND2B driver - 500 W cont.; 90° x 40°, EVCoat, black  
 Order number **EVH-1152S/94-BLKE | F.01U.239.334**

**EVH-1152S/94-WHTE 15" speaker 90x40 indoor white**  
 15" / 2-way Full-range Systems; SMX woofer & ND2B driver - 500 W cont.; 90° x 40°, EVCoat, white  
 Order number **EVH-1152S/94-WHTE | F.01U.239.335**

**EVH-1152S/94-PIBE 15" speaker 90x40 weatherized black**  
 15" / 2-way Full-range Systems; SMX woofer & ND2B driver - 500 W cont.; 90° x 40°, EVCoat, PI-weatherized, black  
 Order number **EVH-1152S/94-PIBE | F.01U.239.336**

**EVH-1152S/94-PIW**  
 15" / 2-way Full-range Systems; SMX woofer & ND2B driver - 500 W cont.; 90° x 40°, EVCoat, PI-weatherized, white  
 Order number **EVH-1152S/94-PIWE | F.01U.239.337**

**Accessories**

**CSG-LB Input panel cover plate single gland nut**  
 Single gland nut cover kit for EVA, EVC, EVF & EVH, black  
 Order number **CSG-LB | F.01U.283.496**

**CDG-LB Input panel cover plate, dual gland nut**  
 Dual gland nut cover kit for EVA, EVC, EVF & EVH  
 Order number **CDG-LB | F.01U.283.497**

**CDNL4-LB Input panel cover plate, dual NL4 type**

Dual NL4 cover kit for EVA, EVC, EVF & EVH, black  
Order number **CDNL4-LB | F.01U.283.495**

---

**TK-150 70/100 Volt transformer kit**

Transformer kit for EVC, EVF, and EVH, 150W/70V  
Order number **TK-150 | F.01U.132.318**

---

**HRK-2B-LB Horizontal rigging kit black, EVF + EVH**

Horizontal rigging kit for EVF & EVH full-range to EVF sub,  
black  
Order number **HRK-2B-LB | F.01U.283.504**

---

**HRK-2W-LB Horizontal rigging kit white, EVF + EVH**

Horizontal rigging kit for EVF & EVH full-range to EVF sub,  
white  
Order number **HRK-2W-LB | F.01U.283.505**

---

**HRK-3B-LB Horizontal rig kit black, EVH + EVH**

Horizontal rigging kit for EVH, black  
Order number **HRK-3B-LB | F.01U.283.498**

---

**HRK-3W-LB Horizontal rig kit white, EVH + EVH**

Horizontal rigging kit for EVH, white  
Order number **HRK-3W-LB | F.01U.283.499**

---

**VRK-2B-LB Vertical rigging kit black, EVF + EVH**

Vertical rigging kit for EVF & EVH full-range to EVF subs,  
black  
Order number **VRK-2B-LB | F.01U.283.508**

---

**VRK-2W-LB Vertical rigging kit white, EVF + EVH**

Vertical rigging kit for EVF & EVH full-range to EVF subs,  
white  
Order number **VRK-2W-LB | F.01U.283.509**

---

**VRK-3B-LB Vertical rig kit black, EVH + EVH**

Vertical rigging kit for EVH, black  
Order number **VRK-3B-LB | F.01U.283.500**

---

**VRK-3W-LB Vertical rig kit white, EVH + EVH**

Vertical rigging kit for EVH, white  
Order number **VRK-3W-LB | F.01U.283.501**

---

**Represented by:**

**Germany:**  
Bosch Sicherheitssysteme GmbH  
Robert-Bosch-Ring 5  
85630 Grasbrunn  
Germany  
www.electrovoice.com

Bosch Security Systems, LLC  
12000 Portland Avenue South  
Burnsville MN 55337  
USA