

X-Line Advance Install

X1i | X2i | X12i-128

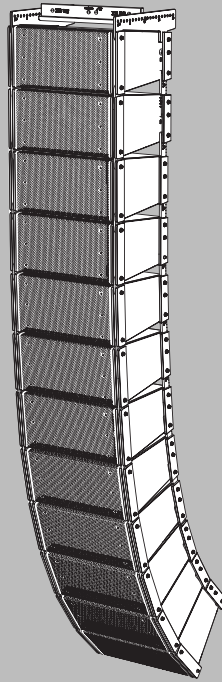

Table of contents

1	Important safety instructions	4
1.1	Suspension	4
1.2	Chlorine	5
1.3	Precautions	5
1.4	Copyright and disclaimer	5
1.5	Symbols	6
1.6	Declaration of conformity	6
2	System overview	7
3	Dimensions	9
3.1	X1i and X2i speaker dimensions	9
3.2	X12i subwoofer dimensions	11
4	Wiring and connections	12
4.1	X1i schematic and wiring diagram	12
4.2	X2i schematic and wiring diagram	12
4.3	X12i-128 schematic and wiring diagram	13
4.4	Installing weather plate and gland nuts	14
5	Designing an X1i or X2i array	16
6	Designing an X12i-128 array	18
6.1	Ground stack subwoofer array	18
6.2	Custom frame example	21
6.3	Single subwoofer suspension using M10 eyebolts	22
6.4	Cardioid subwoofer arrays	24
6.5	Drain holes	26
7	Custom frame design considerations	27
8	Notes	30

1 Important safety instructions

1. Read these instructions.
2. Keep these instructions.
3. Heed all warnings.
4. Follow all instructions.
5. Clean only with a damp cloth. No harsh chemicals or solvents.
6. Do not install near any heat sources such as radiators, heat registers, stoves, or other apparatus (including amplifiers) that produce heat.



Old electrical and electronic appliances

Electrical or electronic devices that are no longer serviceable must be collected separately and sent for environmentally compatible recycling (in accordance with the European Waste Electrical and Electronic Equipment Directive).

To dispose of old electrical or electronic devices, you should use the return and collection systems put in place in the country concerned.

1.1 Suspension

Warning!

Read and fully understand the manual and all safety instructions before attempting to suspend this loudspeaker. Qualified professionals must carry out suspension and installation. Follow all applicable local laws and regulations. Incorrect or improper suspension could expose persons to serious injury or death. Carefully inspect loudspeakers and associated hardware for defects or signs of damage before proceeding to suspend the speakers. Inspect all components at least once per year or as local laws and regulations require. If any parts are damaged or suspect, or if there is any doubt as to the proper functioning and safety of the items, stop using them immediately. It is the responsibility of the person installing the assembly to make sure the wall, ceiling, structure, and any attachments are capable of supporting all objects suspended overhead. Any hardware used to suspend a loudspeaker not provided by Electro-Voice is the responsibility of others. Electro-Voice assumes no liability for any damage or personal injury resulting from improper use, installation, or operation of the product.



Warning!

Never suspend Electro-Voice loudspeakers in a manner other than explicitly described in this manual. Never modify Electro-Voice loudspeakers or rigging components or use a partial assembly of rigging components.

Only use rigging components with the loudspeaker models they are designed for.



Warning!

Arrays designed for outdoor use must take into account environment effects such as wind loads, snow or any other condition that can add external forces to the array. Always use a qualified professional to certify outdoor arrays for safety to local environmental conditions.





1.2 Chlorine



Warning!

These Electro-Voice loudspeakers have structural components that use stainless steel. Chlorine can degrade stainless steel over time and reduce its structural performance. Do not use these Electro-Voice loudspeakers in environments with high chlorine content, such as indoor swimming pools. Failure to do so can result in serious injury or death.

1.3 Precautions

	These Electro-Voice loudspeakers were designed for use in an environment with ambient temperatures between -20°C (-4°F) and +50°C (122°F).
	Indoor X-Line Advance Install loudspeakers are not designed for direct exposure to rain and/or outdoor environments. Use only fully weatherized loudspeaker versions for direct outdoor and rain exposure.
	Electro-Voice loudspeakers are easily capable of generating sound pressure levels sufficient to cause permanent hearing damage. Caution should be taken to avoid prolonged exposure to sound pressure levels exceeding 90 dB.

1.4 Copyright and disclaimer

All rights reserved. No part of this document may be reproduced or transmitted in any form by any means, electronic, mechanical, photocopying, recording, or otherwise, without the prior written permission of the publisher. For information on getting permission for reprints and excerpts, contact Electro-Voice.

All content including specifications, data, and illustrations in this manual are subject to change without prior notice.

1.5 Symbols



Warning!

A safety helmet, safety boots, and safety glasses must be used at all times during the installation of the X-Line Advance install system.

Failure to do so can result in injury or death.



1.6 Declaration of conformity

Bosch Security Systems Inc.

130 Perinton Pkwy, Fairport, NY 14450 USA

Hereby declares conformity to the following standards:

- IEC60065:2014
- IEC60529 IP55 (FG models only)
- RoHS 3 EU 2015/853
- ISO 12100:2010
- DGUV Regulation 17

2 System overview

The X-Line Advance Install loudspeaker is a premium line-array loudspeaker system designed for high performance permanent install applications, such as sports arenas, houses of worship, and performing arts centers. The system represents a culmination of EV's extensive experience in designing large format line array systems for touring applications, as well as deep knowledge in designing ruggedized install loudspeaker systems that can survive in harsh, direct exposure environments.

All models feature stainless steel hardware and grilles, weatherized transducers, and durable void-free birch enclosures with internal bracing and a rugged polyurea coating. The heavy-duty cast aluminum input panel has dual 8-conductor terminal blocks with a current capacity that exceeds 40 amps continuous. Plates with gland nuts are included with each speaker to fully seal the terminal blocks inside the input panel and to present a clean, consistent look for the rear of the loudspeaker.

The fiberglass models are specifically designed for harsh environments, including direct exposure to the elements. In addition to the features already described, each fiberglass enclosure is coated with a durable fiberglass resin on all external and internal surfaces to seal the marine-grade plywood. The grilles are backed with a special hydrophobic cloth that minimizes water intrusion without impeding the acoustic output of the speaker.

X-Line Advance Install is part of a comprehensive product portfolio for commercial and installation applications, capable of supplying a complete system solution. This includes the main loudspeaker system, rigging, amplifiers, digital signal processing, and paging loudspeakers. By providing an entire system solution, we ensure optimum performance, consistency and reliability.

X-Line Advance Install is designed to be powered and controlled by Dynacord IPX series amplifiers and SONICUE sound system control software. Presets for all X-Line Advance Install products are configured within SONICUE for ease of setup and installation. Drive electronics for X-Line Advance Install can also be configured, controlled and monitored in EV's IRIS-Net software environment.

Users can configure X-Line Advance Install arrays with EV's proprietary **PREVIEW Loudspeaker Software**. **PREVIEW** will also validate the mechanical forces at each rigging connection point and will warn the designer if any part of the array is deployed beyond a safe working load. **PREVIEW Loudspeaker Software** must be used in order to properly design and suspend the array.

X1i Passive line array elements

Each X1i-212 full-range element consists of one SMX2121 12-inch (304.8 mm) LF driver coupled to a MBH (Mid Band Hydra), and two ND2R 2-inch (50.8 mm) titanium diaphragm HF drivers. Each HF driver is mounted on a Wavefront-shaping Circular Hydra (WCH) planar-wave. Each X1i element is designed in a two-way configuration, with either 90° or 120° horizontal coverage pattern, and 10° vertical coverage pattern. X1i elements have an integrated passive crossover and EQ network, which allows multiple elements to be driven on a single amplifier channel. The enclosure is trapezoidal in the vertical plane with a 10° total included angle. X1i is available in indoor and fully weatherized configurations, as well as white and black colors. Grids and rigging kits are available to suspend each element in a variety of array configurations, and eight M10 hard points are built into the product to suspend the array from third-party structural frames.

X2i Biamp line array elements

Each X2i-212 full-range element consists of one DVN3125 12-inch (304.8 mm) LF driver coupled to a MBH, and two ND6A 3-inch (76.2 mm) titanium diaphragm HF drivers. Each HF driver is mounted on a Pin Diffraction Hydra (PDH) planar-wave generator. Each X2i element is designed in a two-way configuration, with either 90° or 120° horizontal coverage pattern, and 10° vertical coverage pattern. X2i can be driven in biamp mode only. The enclosure is trapezoidal in the vertical plane with a 10° total included angle. X2i is available in indoor and fully weatherized configurations, as well as white and black colors. Grids and rigging kits are available to suspend each element in a variety of array configurations, and eight M10 hard points are built into the product to suspend the array from third-party structural frames.

X12i-128 Subwoofer system

X12i-128 is a high output dual-18-inch (457.2 mm) subwoofer element designed for use in large subwoofer arrays. The X12i-128 subwoofer includes two high output DVF4180 woofers designed specifically for subwoofer applications, providing reliable low-frequency performance at high SPL levels. Subwoofer elements do not have internal passive crossovers and require an active crossover and dedicated amplifier channel(s) for proper operation. The X12i-128 is available in an indoor version that can be suspended or ground stacked, as well as a fully weatherized version that can be suspended. Each variant is also available in white or black finish.

X12i-GRID and X12i-RIGKIT line array rigging system

The X12i-GRID and X12i-RIGKIT are accessories that can suspend up to twelve X1i or X2i elements. The grid connects to the top element in the array and is suspended from the venue. At least one grid is required at the top of the array. A second grid may be used at the bottom of the array to create a pullback point to the venue. The rigging kit is used to suspend each element in the array to the element above, or to the grid. Use one rigging kit for each element in the loudspeaker array. The X12i-GRID and X12i-RIGKIT use aluminum plates and stainless steel hardware to ensure the rigging components will not corrode over time in direct exposure environments.

3 Dimensions

3.1 X1i and X2i speaker dimensions

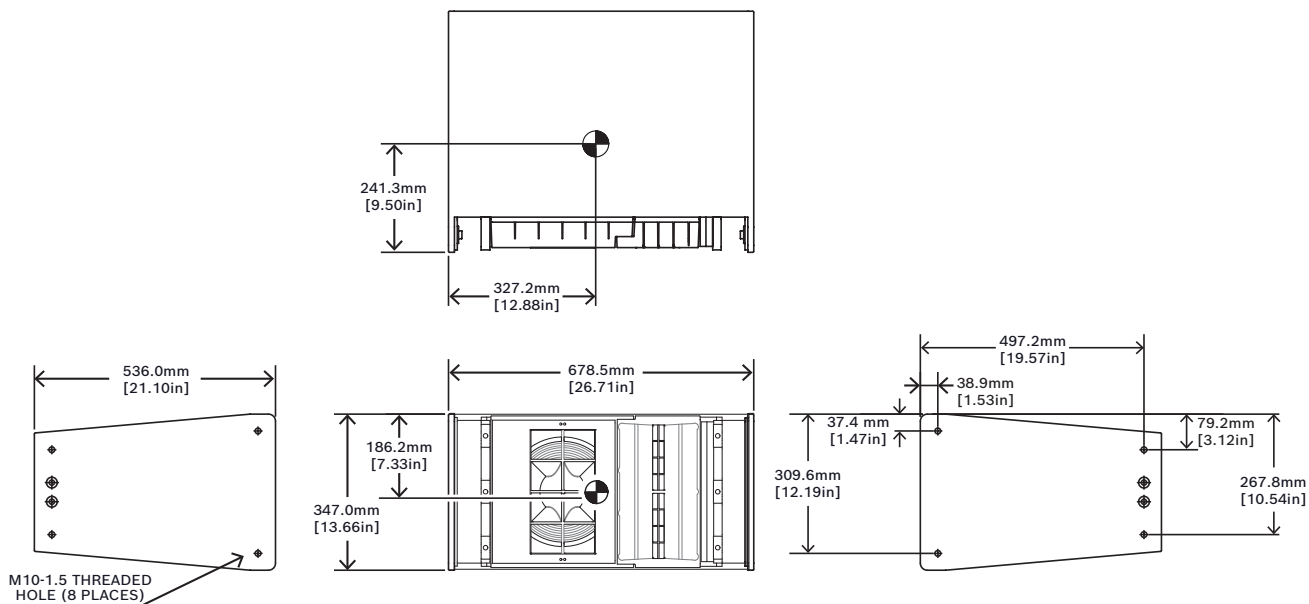

Figure 3.1: X1i dimensions without rigging

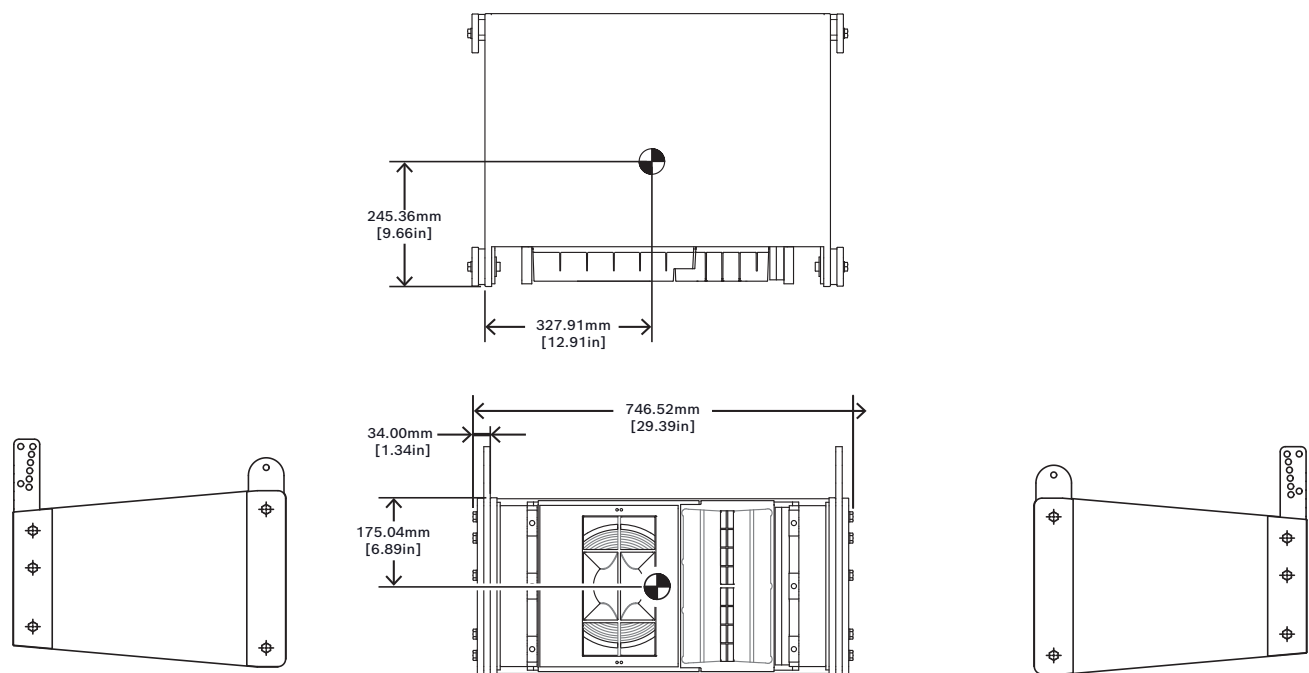

Figure 3.2: X1i dimensions with rigging

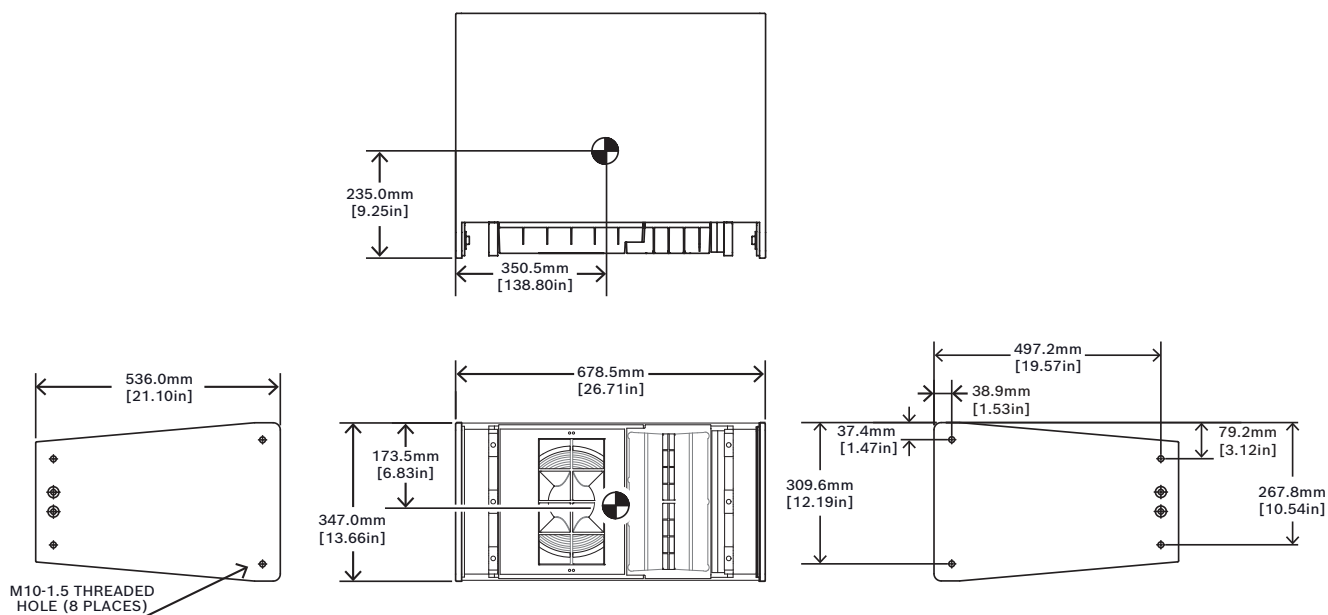

Figure 3.3: X2i dimensions without rigging

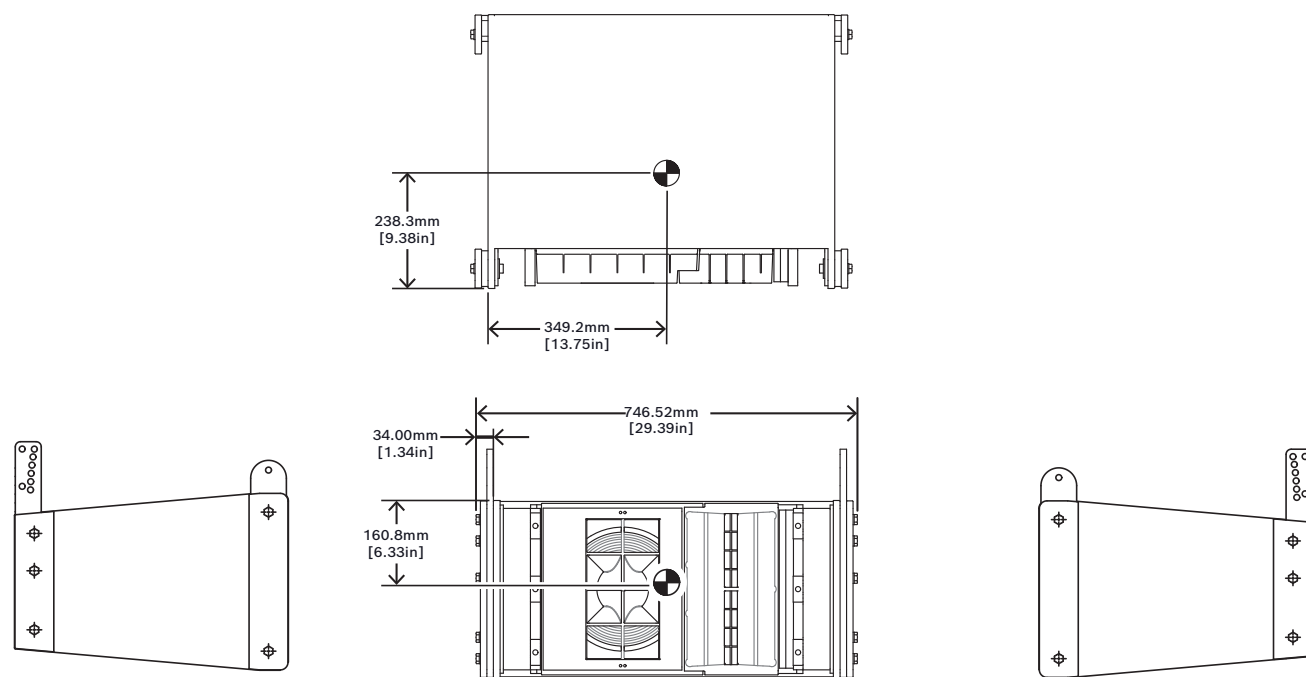
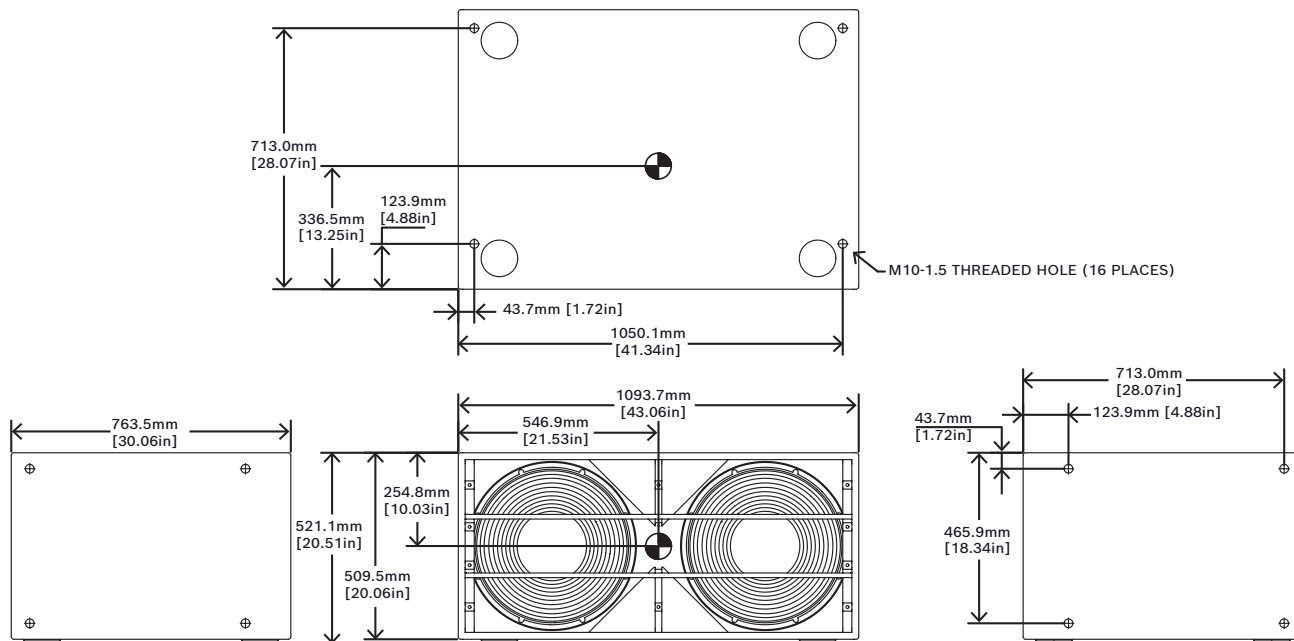



Figure 3.4: X2i dimensions with rigging

3.2 X12i subwoofer dimensions



Notice!

The  symbol denotes the center of mass of the loudspeaker.

4 Wiring and connections

X-Line Advance Install loudspeakers utilize heavy duty input panels, with dual 8-conductor Phoenix terminal blocks (Phoenix Contact P/N 1709212). The connectors can accommodate up to 8 AWG stranded wire. Each loudspeaker includes a weather plate and gland nuts to ensure that all electrical contacts are protected from rain. The weather plate and gland nuts are required for speakers used in outdoor environments. For indoor environments, the weather plate and gland nuts are not required, but recommended for added security and concealment of the cables.

4.1 X1i schematic and wiring diagram

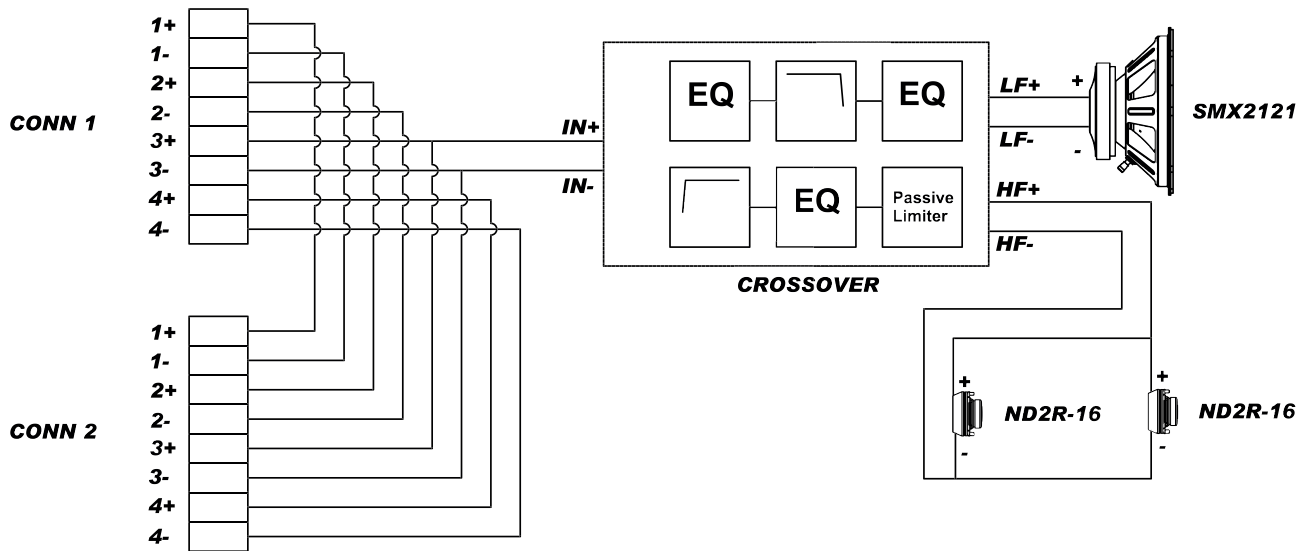

4.2 X2i schematic and wiring diagram

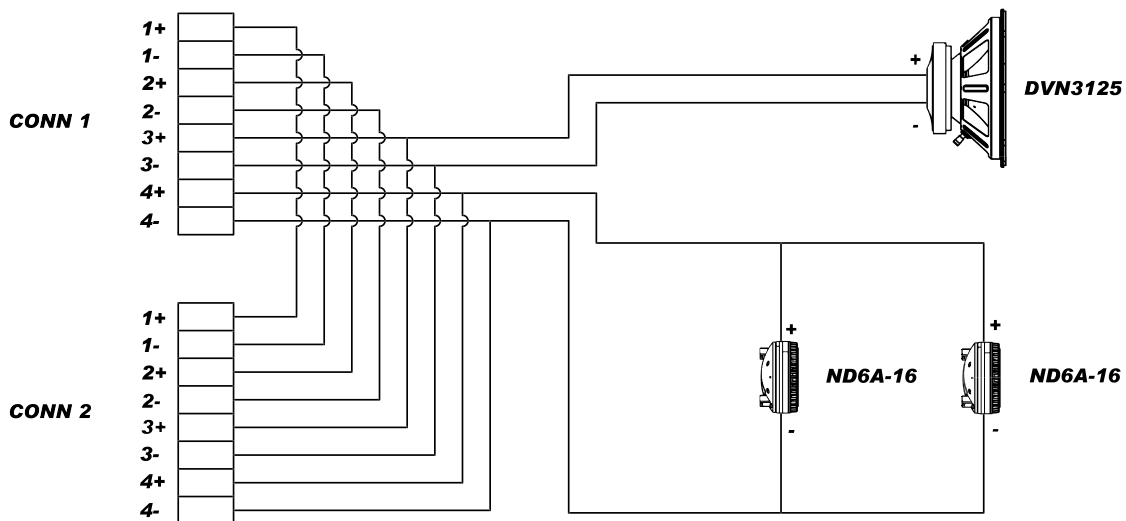

4.3 X12i-128 schematic and wiring diagram

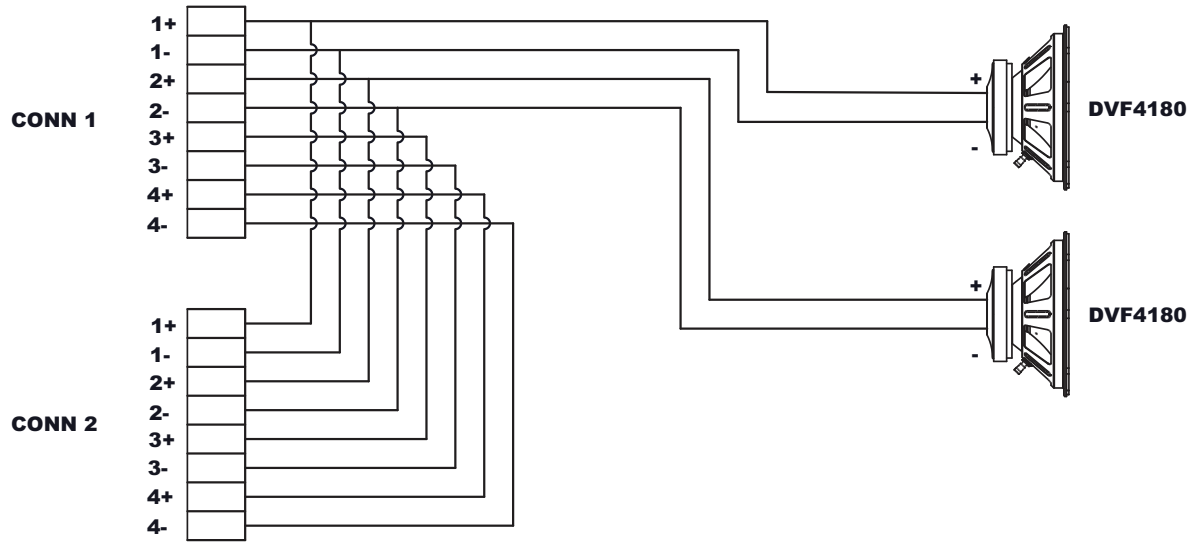

4.4 Installing weather plate and gland nuts

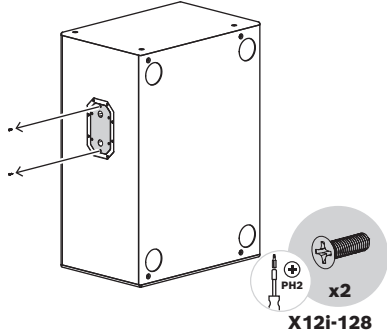
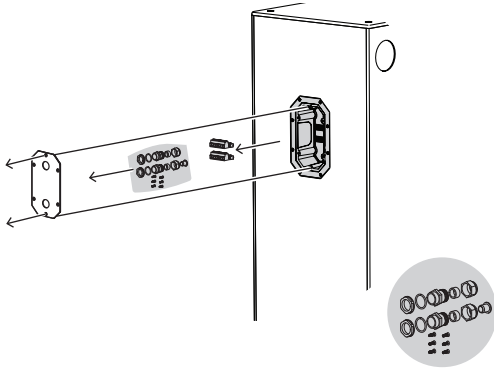
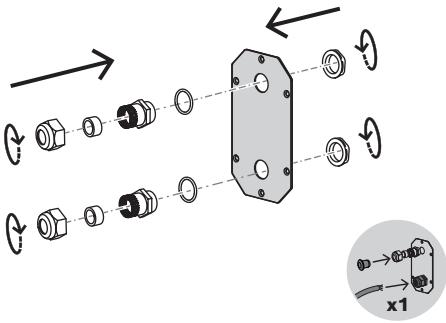
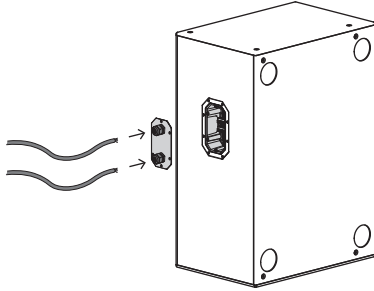
	<ol style="list-style-type: none"> 1. Remove the weather plate and (2) screws (X12i-128 only) from the input panel.
	<ol style="list-style-type: none"> 2. Remove the gland nut kit and (2) terminal block connectors from inside the input panel.
	<ol style="list-style-type: none"> 3. Install the gland nuts onto the plates. If the loudspeaker only requires one cable, use the gland nut plug on one of the gland nuts.
	<ol style="list-style-type: none"> 4. Feed the cable through the gland nut and weather plate.

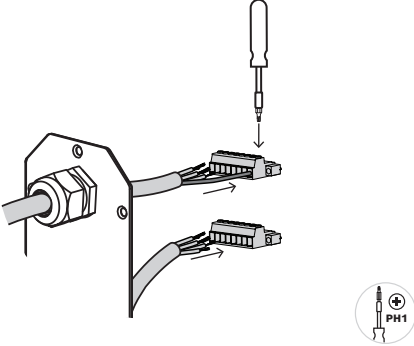
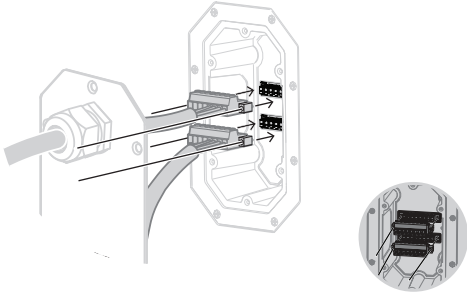
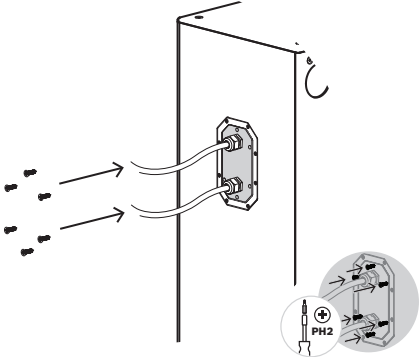
	<p>5. Connect each wire to the appropriate terminal on the terminal block.</p>
	<p>6. Connect the terminal block onto the input connector, and secure in place with the (2) captive screws. Adjust the cable assembly in the cup and tighten the gland nuts.</p>
	<p>7. Install the weather plate to the input cup using the (6) screws.</p>

5 Designing an X1i or X2i array

X1i and X2i rigging methods

There are two methods of deploying X1i and X2i line arrays: With a custom frame, or with the optional Electro-Voice grid and rigging kits. The Electro-Voice grid and rigging kits (sold separately) are a cost-effective method to suspend smaller, simple arrays quickly. One rigging kit is needed for each element in the array. Each array requires at least one grid. Larger and more complex arrays will require a custom frame. Custom frames are not designed or provided by Electro-Voice and need to be provided by third parties.



Warning!

Qualified professionals must carry out the design, construction, and installation of custom frames, in accordance with applicable laws and regulations. Any hardware used to suspend a loudspeaker not provided by Electro-Voice is the responsibility of others.

Custom rigging frame	X12i-GRID and X12i-RIGKIT

In general, a custom rigging frame should be used when:

- more than twelve elements are needed in the array.
- the application requires a steep down angle.
- the array requires excessive curvature.
- other loudspeakers, such as the X12i subwoofer, need to be suspended in the same array.

In general, the grid and rigging kits can be used when:

- the array consists of twelve or fewer elements.
- the array does not require a steep down angle.
- the array does not have excessive curvature.



Notice!

These are general guidelines only. Always use **PREVIEW** to determine if a particular array can be used with the rigging kits and grid.



Warning!

PREVIEW Loudspeaker Software MUST be used to design the array. **PREVIEW** will state whether the array configuration is valid for use with the X12i-RIGKIT and X12i-GRID accessories. Follow all warnings within the software. Failure to design the array properly may result in serious injury or death.

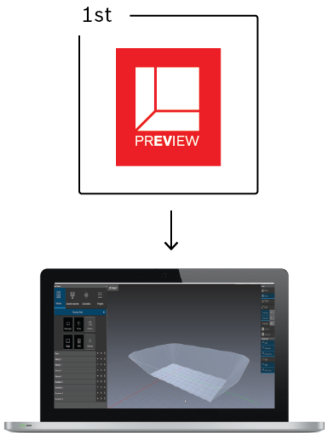
	<ol style="list-style-type: none">1. Use PREVIEW Loudspeaker Software to design the array. PREVIEW will determine whether the array can be suspended with the optional grid and rigging kits for your particular application, with the safety factor that you determine based on local laws and regulations.2. If PREVIEW states the array configuration is valid, the optional grid and rigging kit may be used to suspend the array. Follow the directions in the X-Line Advance Install Rigging manual, available at www.electrovoice.com3. If PREVIEW determines that the desired array configuration is not valid or not possible, a custom rigging solution is needed. Please see section <i>Custom frame design considerations</i>, page 27
--	--



Notice!

Electro-Voice has experienced and knowledgeable application engineers willing to assist with any design related questions. Contact information for technical support is located at www.electrovoice.com

6 Designing an X12i-128 array

There are 3 methods of installing X12i-128 subwoofers.

- Ground stack
- Custom frame
- Single subwoofer suspended with M10 eyebolts

6.1 Ground stack subwoofer array

X12i-128 subwoofers can be ground stacked using the feet that are included with the subwoofer. The feet interlock with recesses in the subwoofer enclosure to ensure that the subwoofers do not “walk” and tip over. Indoor subwoofer models are ground stackable, but fiberglass versions are not.

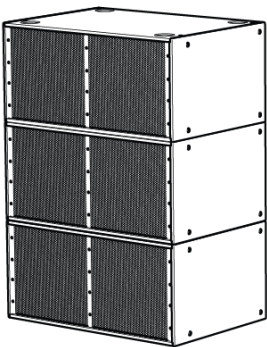
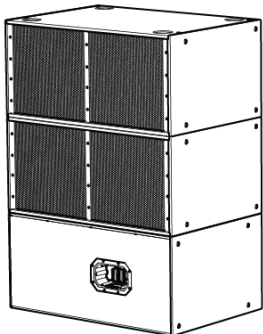
Standard ground stack array	Cardioid ground stack array
	



Warning!

Use two or more people to lift and move X12i-128 subwoofers. Failure to do so can result in injury.

Warning!

Do not stack four or more X12i-128 subwoofers horizontally.
Never stack two or more X12i-128 subwoofers vertically.
Failure to do so can result in injury or death.

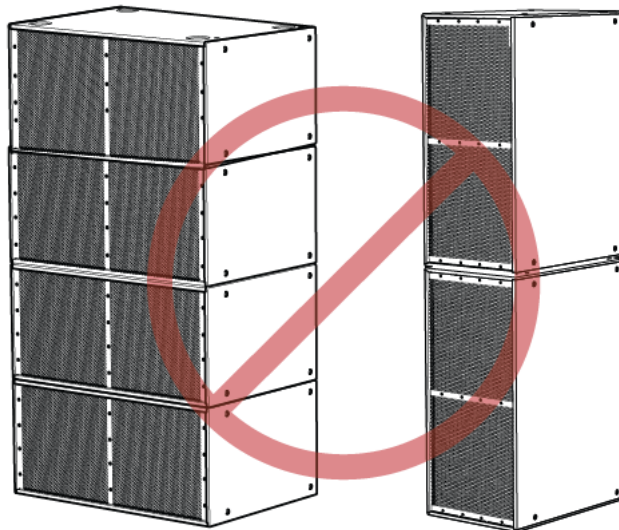

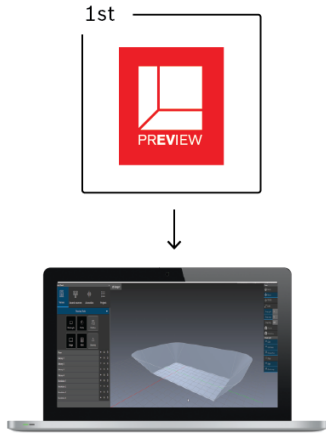
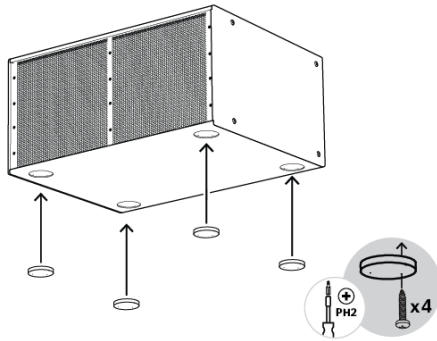
<p>1st</p> 	<p>1. Use PREVIEW to design the array.</p>
	<p>2. Attach feet to bottom of subwoofer.</p>

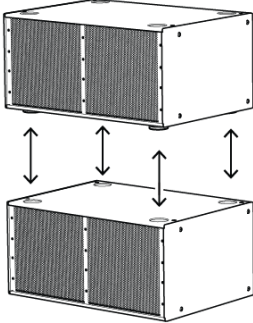
	<p>3. Stack subwoofers into the array. The feet from each added subwoofer will fit into the recesses on the subwoofer below. Repeat as necessary to complete the array.</p>
---	---

6.2 Custom frame example



Warning!

Qualified professionals must carry out the design, construction, and installation of custom frames, in accordance with applicable laws and regulations. Any hardware used to suspend a loudspeaker not provided by Electro-Voice is the responsibility of others.

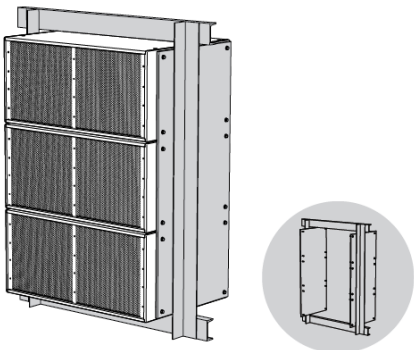
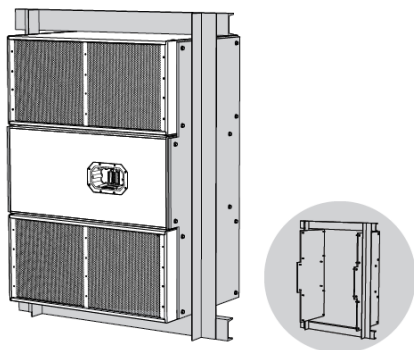
Standard custom frame	Cardioid array in custom frame
	



Warning!

Use two or more people to lift and move X12i-128 subwoofers. Failure to do so can result in injury.

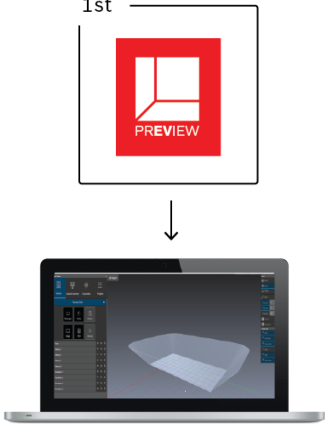
<p>1st</p> 	<p>1. Use PREVIEW to design the array.</p>
--	---

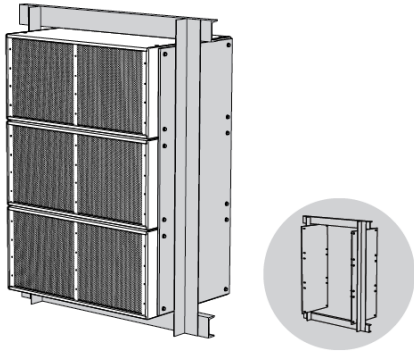
	<p>2. Design the custom frame according the guidelines in <i>Custom frame design considerations</i>, page 27.</p>
---	---

6.3 Single subwoofer suspension using M10 eyebolts

X12i-128 indoor and fiberglass models can be suspended individually using the M10 hard points. There are sixteen M10 points available on the subwoofer, four on each side of the enclosure, four on the top of the enclosure and four on the bottom of the enclosure.

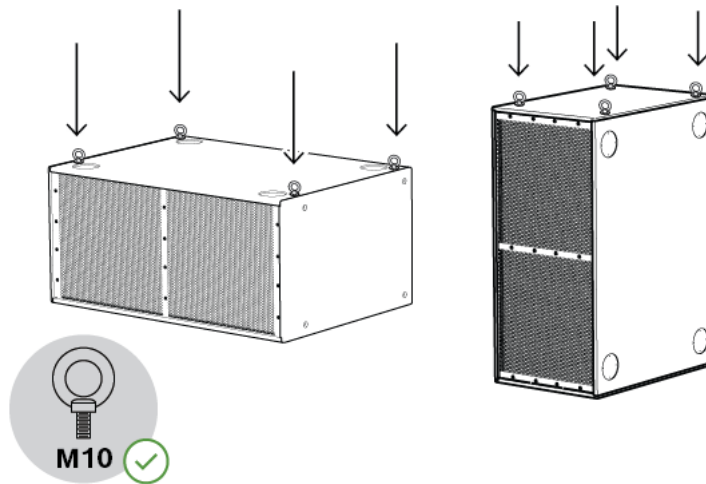

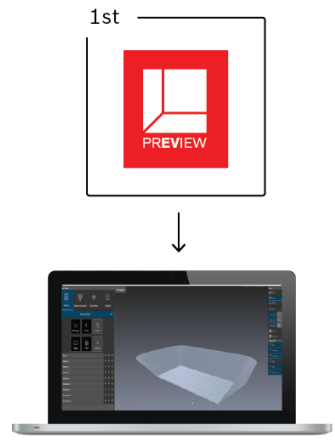
<p>1st</p> 	<p>1. Use PREVIEW to check the acoustic coverage.</p>
--	--

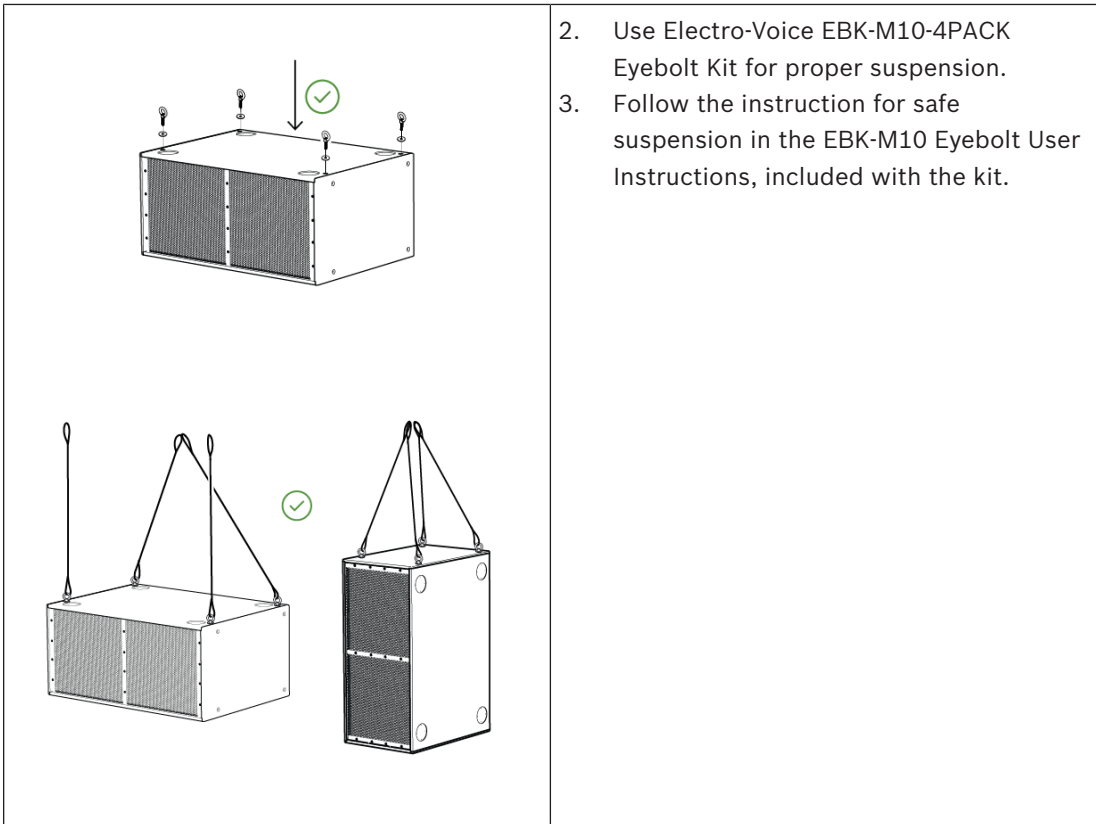

Warning!

Always suspend X12i-128 from the top of the enclosure, relative to its orientation. Never suspend an X12i-128 or any other speaker from the bottom of an X12i-128. Failure to heed these warnings may result in serious injury or death.

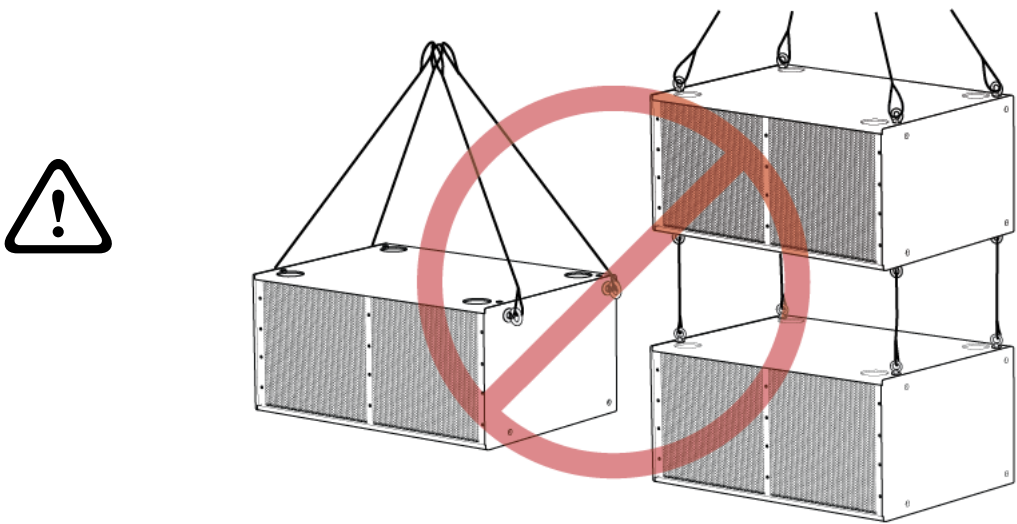

6.4 Cardioid subwoofer arrays

By using a cardioid configuration, the output of multiple X12i-128 subwoofers can be directed toward the audience while at the same reducing the low-frequency energy behind the array. These arrays can be used to keep bass off of a stage, provide more consistent bass coverage in the audience, or reduce bass in the surrounding area.

A cardioid deployment requires at least two X12i-128 subwoofers. Electro-Voice provides optimized DSP speaker settings for the X12i-128 in cardioid configurations. These settings can be implemented in hardware controlled by SONICUE or IRIS-Net software. In addition, you can model the acoustical output of cardioid arrays in **PREVIEW Loudspeaker Software**. Contact information for technical support is located at www.electrovoice.com.

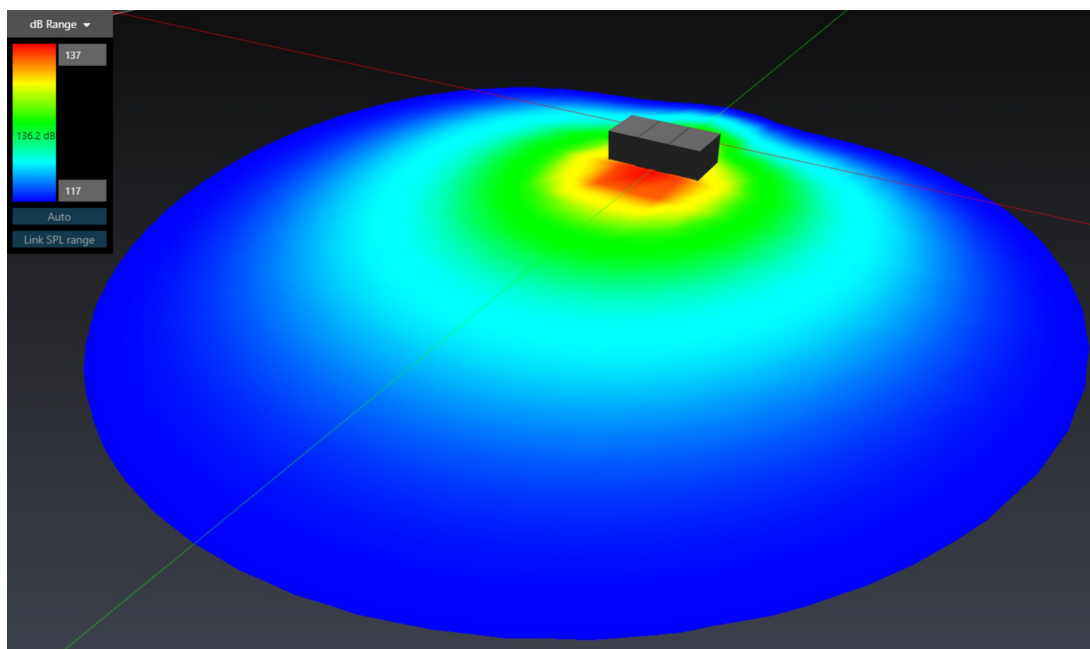

The rejection may be less in smaller indoor environments than in larger outdoor environments. The subwoofers must be physically placed in one of the options shown.

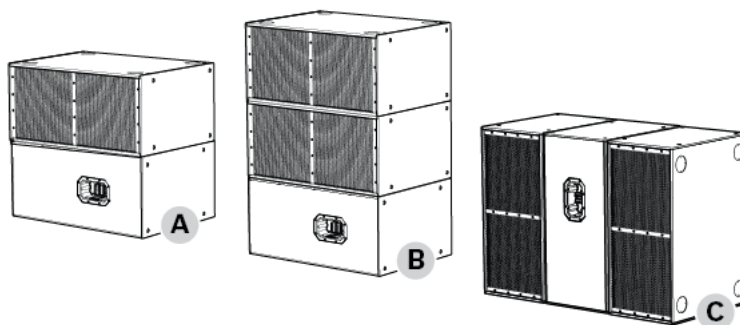
**Cardioid option A:**

Two X12i-128 subwoofers orientated horizontally. Direct the top subwoofer towards the audience and the bottom subwoofer away from the audience.

Cardioid option B:

Three X12i-128 subwoofers orientated horizontally. For ground stack applications, direct the top two subwoofers towards the audience and the bottom subwoofer away from the audience. For flown applications, the middle subwoofer should be facing away from the audience instead of the bottom subwoofer.

Cardioid option C:

Three X12i-128 subwoofers orientated vertically. Direct the left and right subwoofers towards the audience and the center subwoofer away from the audience.

6.5 Drain holes

The X12i-128 fiberglass models have optional drain holes on the bottom of the enclosure. The drain holes are designed to drain any water that may accumulate over time.

In applications where the X12i-128 is located in an environment with direct rain exposure, Electro-Voice recommends that the drain holes are used.

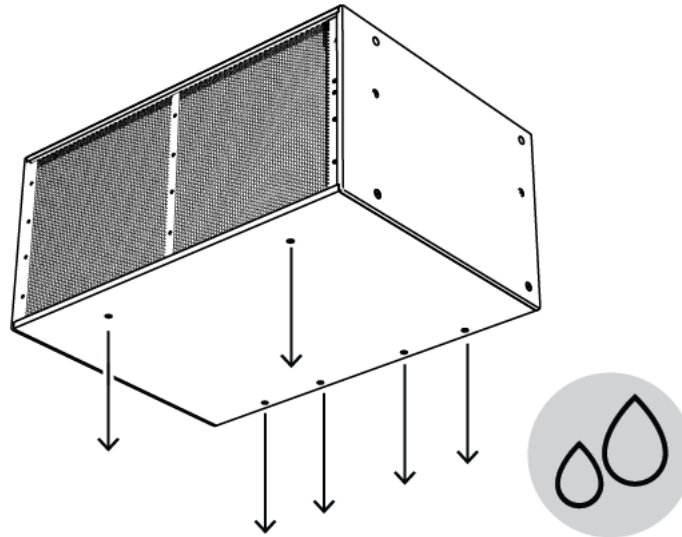

Notice!

Opening the drain holes may cause minor air noises close to the subwoofer that will be inaudible at normal listening distances.

	<ol style="list-style-type: none"> 1. Determine if the subwoofer(s) will be angled upward (A), flat (B), or angled downward (C).
	<ol style="list-style-type: none"> 2. Option A: remove the (4) M8 screws towards the back of the subwoofer enclosure. 3. Option B: remove all (6) M8 screws on the bottom of the subwoofer enclosure. 4. Option C: remove the (2) M8 screws towards the front of subwoofer enclosure.

7 Custom frame design considerations



Warning!

Suspending any object overhead is potentially dangerous and should only be attempted by individuals who have a thorough knowledge of the techniques and regulations of suspending objects overhead.

Only certified structural engineers should be used to design any custom suspension frame. Failure to do so could result in serious injury or death.



Warning!

Any hardware used to suspend a loudspeaker array not associated with Electro-Voice is the responsibility of others.



Warning!

The simplified designs shown are for illustrative purposes only and do not represent or imply a complete design from Electro-Voice.

Any custom framing must be designed by experienced structural engineering in accordance with local laws and regulations.

Electro-Voice does not take responsibility for any custom suspension system.

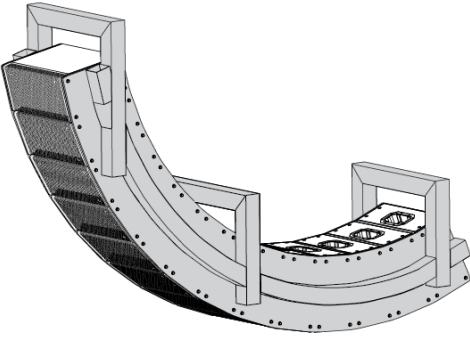
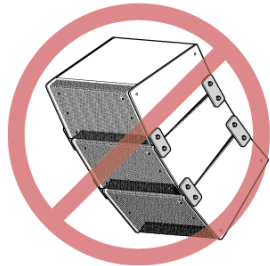
Correct	Incorrect
<p data-bbox="383 1027 933 1095">Suspend each element of the array from the frame.</p> 	<p data-bbox="933 1027 1492 1095">DO NOT suspend one element from the bottom of another element.</p> 

Use all eight M10 structural hard points on the loudspeaker element, four on each side of the element.

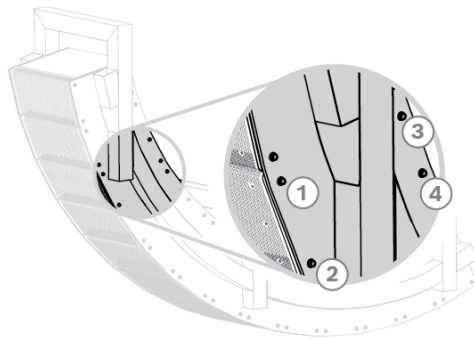

DO NOT use only some of the M10 hard points.

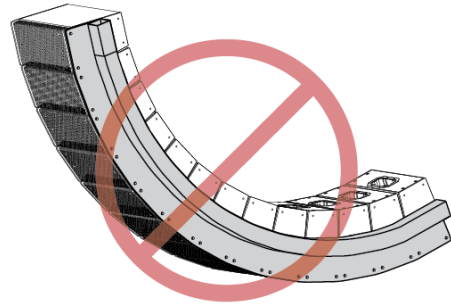

DO NOT modify the loudspeaker to add a custom hard point. Use only the M10 hard points provided.

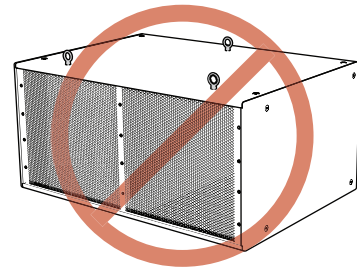

Custom frame must be rigid between side mounting points. Install lateral support bars after the loudspeakers are mounted to the frame sides to ensure they are tight to the loudspeakers.

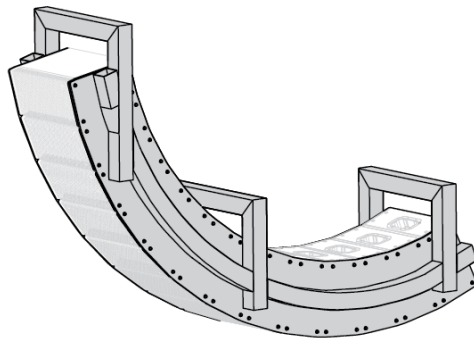

DO NOT use plates on each side of the array without lateral support.

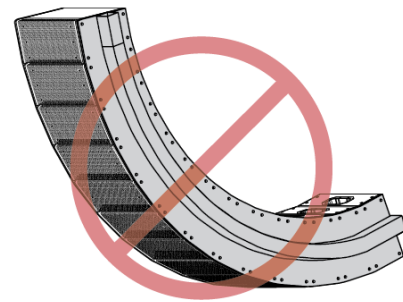

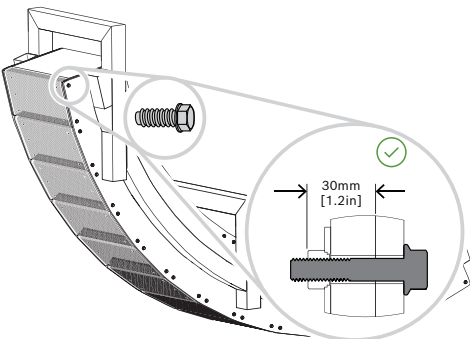
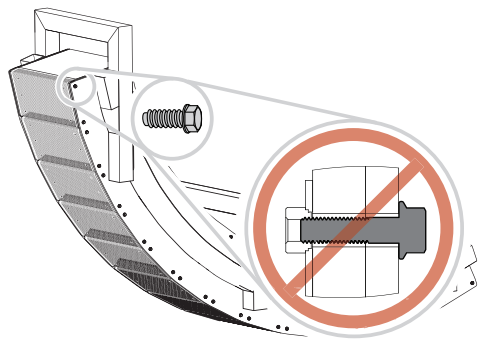
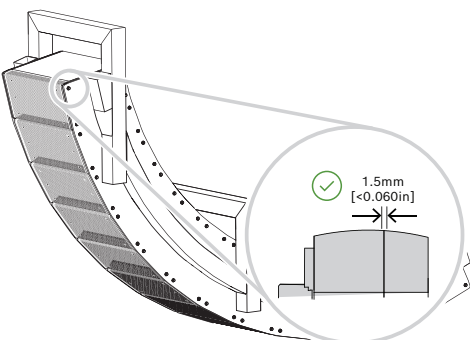
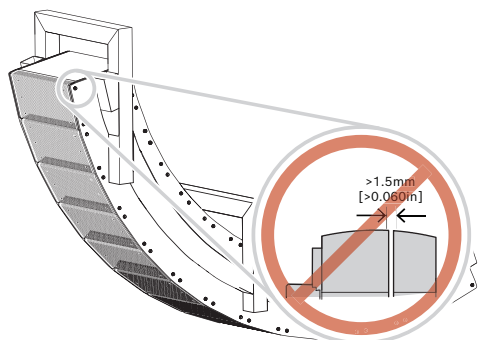
<p>Use M10 fasteners that penetrate the loudspeaker element 30 - 45 mm (1.2 - 1.8 in). Use thread locker and appropriate torque for the type of fastener used. Fastener torque must not exceed 13.5 N*m (120 in*lbs). Only use fasteners that are capable of supporting the weight of the loudspeaker with a safety factor appropriate for local laws and regulations.</p>  <p>The diagram shows a cross-section of a curved loudspeaker enclosure. A callout shows a green checkmark next to a fastener that has penetrated the enclosure by 30mm (1.2in). A dimension line indicates this penetration depth.</p>	<p>DO NOT use fasteners that are too long or too short.</p>  <p>The diagram shows a cross-section of the enclosure with a callout showing a red prohibition sign over a fastener that is too long, protruding through the enclosure.</p>
<p>The gap between the custom frame and the enclosure must be less than 1.5 mm (0.06 in).</p>  <p>The diagram shows a cross-section of the enclosure with a callout showing a green checkmark and a dimension line indicating a gap of 1.5mm (<0.060in).</p>	<p>DO NOT allow any gap between the enclosure and the custom frame that exceeds 1.5 mm (0.06 in).</p>  <p>The diagram shows a cross-section of the enclosure with a callout showing a red prohibition sign over a gap that is greater than 1.5mm (>0.060in).</p>

8 Notes

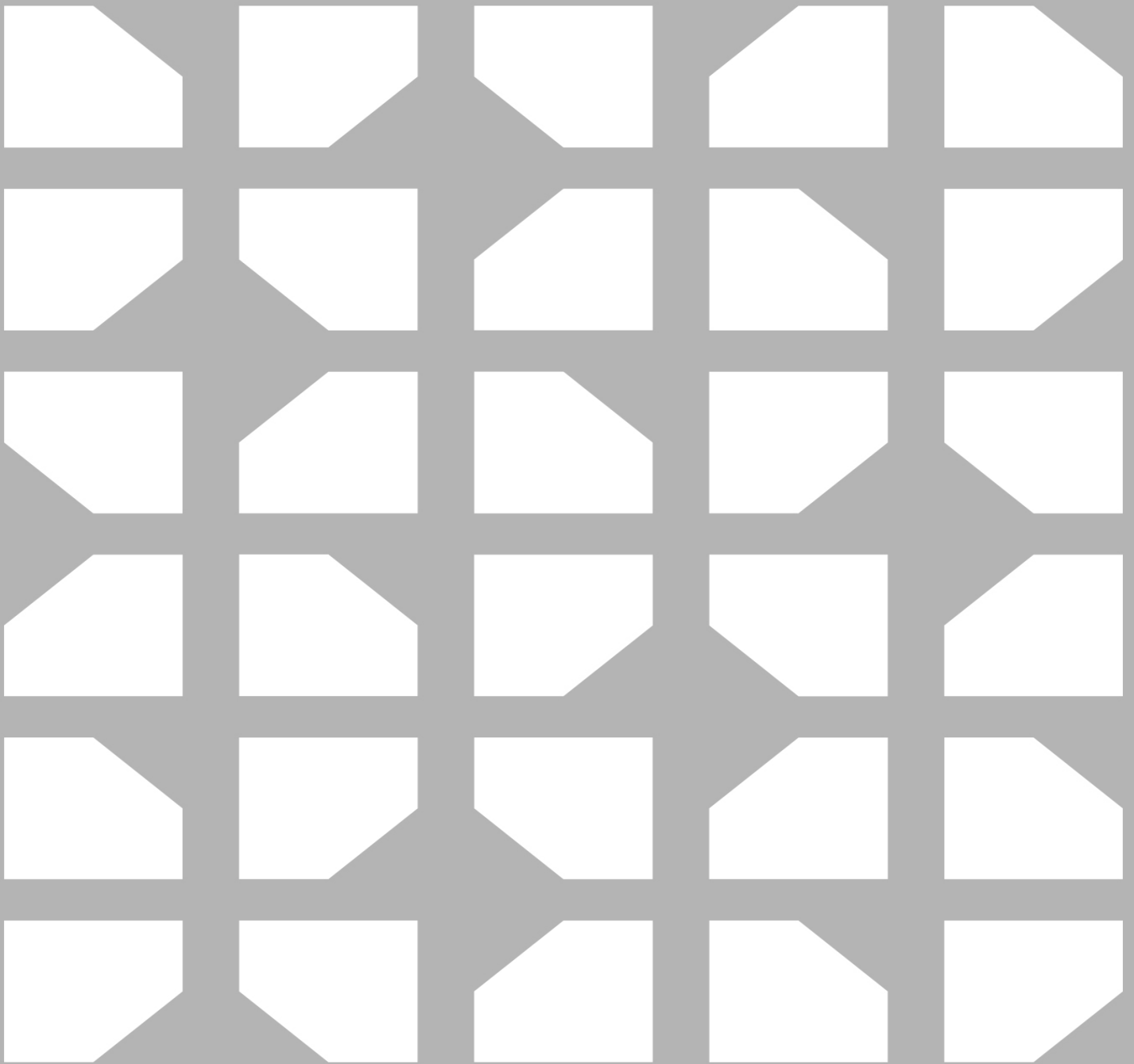

Bosch Sicherheitssysteme GmbH

Robert-Bosch-Ring 5
85630 Grasbrunn
Germany

www.boschsecurity.com

© Bosch Sicherheitssysteme GmbH, 2019

Bosch Security Systems, Inc

12000 Portland Avenue South
Burnsville MN 55337
USA

www.electrovoice.com

© Bosch Security Systems, Inc., 2019