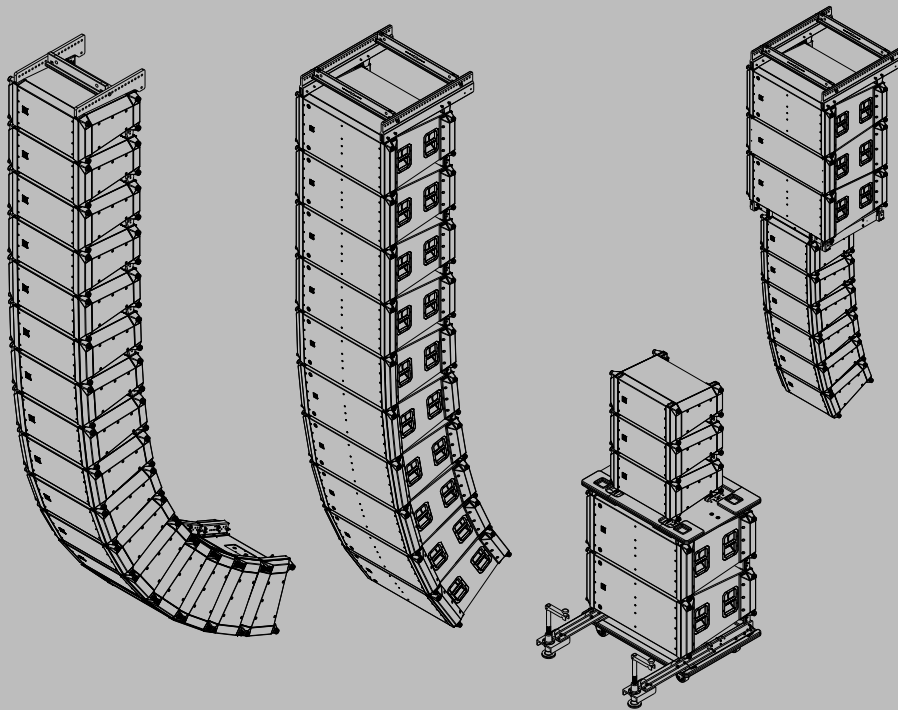


# X-LINE ADVANCE System Rigging & Transport





## Table of contents

<b>1</b>	<b>Safety</b>	<b>5</b>
1.1	Important safety instructions	6
1.2	Suspension	6
1.3	Precautions	6
1.4	Notices	6
<b>2</b>	<b>Short Information</b>	<b>8</b>
<b>3</b>	<b>System overview</b>	<b>9</b>
<b>4</b>	<b>Designing an X-Line Advance speaker system array</b>	<b>12</b>
4.1	Applications for which X-Line Advance arrays are most appropriate	12
4.2	Electro-Voice line array configuration software	12
<b>5</b>	<b>Preparing X-Line Advance elements for installation</b>	<b>13</b>
5.1	Unpacking and inspection	13
5.2	Scope of delivery	13
5.3	Recommended preflight procedures	13
5.4	Element configuration	13
<b>6</b>	<b>Rigging system</b>	<b>14</b>
6.1	Overview of the flying system	14
6.2	Rigging the elements together	14
6.3	Setting rear link angles	15
6.3.1	Single pin and double pin	17
<b>7</b>	<b>Transportation dollies</b>	<b>20</b>
7.1	Stacking X1, X2, and X12-125F elements onto a dolly	21
7.1.1	X12T-DOLLY side panels and top cover	25
7.1.2	X12-125F-DOLLY top cover	26
7.2	X12-125F-DOLLY accessories	27
7.2.1	Installing the X12-125F-DAK dolly adapter kit onto the top cover of the X12-125F-DOLLY	27
7.2.2	Assembling an X12-125F-DOK dolly outrigger kit to an X12-125F-DOLLY	29
7.3	Stacking X12-128 subwoofers onto a X12-128-DOLLY	30
7.3.1	X12-128-DOLLY top cover and ratchet strap	32
<b>8</b>	<b>Ground stacking</b>	<b>33</b>
8.1	Ground stacking X1/X2 loudspeakers	33
8.2	Ground stacking subwoofers	33
8.2.1	Subwoofer array configuration	34
8.2.2	Subwoofer cardioid options	36
8.2.3	Installing the X12-125F-CGK Cardioid Grille Kit	37
8.3	Ground stacking a mixed array	38
<b>9</b>	<b>Flying the system</b>	<b>40</b>
9.1	Deciding which grid configuration to use	40
9.1.1	X12TC-GRID compact grid	40
9.1.2	X12TE-GRID extended grid	43
9.1.3	X12PU-BGK or X12-125FPU-BGK pull-up kits	47
9.1.4	X12-125F-GRID grid	53
9.1.5	X12-125F-AG adapter grid for X1/X2 to X12-125F flying subwoofer	54
9.2	Assembling and flying an array	55
9.2.1	Lifting and flying arrays directly from a dolly	55
9.2.2	X12TC-GRID with pull-back to venue	58
9.2.3	Storing empty dollies	59
9.2.4	Landing arrays onto a dolly	60

---

<b>9.3</b>	Array building techniques	<b>65</b>
<b>9.3.1</b>	Multiple ways to fly the X12TC-GRID	<b>65</b>
<b>9.3.2</b>	Multiple ways to fly the X12TE-GRID	<b>66</b>
<b>9.3.3</b>	Array build strength considerations	<b>67</b>
<b>10</b>	<b>Rigging structural strength ratings and safety factors</b>	<b>69</b>
<b>10.1</b>	Structural introduction	<b>69</b>
<b>10.2</b>	Structural rating overview	<b>69</b>
<b>10.3</b>	Electro-Voice line array configuration software structural evaluations simplified structural rating guidelines	<b>70</b>
<b>10.4</b>	Specific safety considerations	<b>70</b>
<b>10.5</b>	Working-load limit and safety factor definitions	<b>71</b>
<b>11</b>	<b>Rigging inspection and precautions</b>	<b>73</b>
<b>12</b>	<b>Technical data</b>	<b>74</b>
<b>12.1</b>	Dimensions	<b>76</b>
<b>12.2</b>	Accessories	<b>77</b>
<b>12.2.1</b>	Accessories technical data	<b>77</b>
<b>12.2.2</b>	Accessories dimensions	<b>80</b>
<b>13</b>	<b>References</b>	<b>90</b>
<b>13.1</b>	Rigging (printed)	<b>90</b>
<b>13.2</b>	Mechanical engineering (printed)	<b>90</b>
<b>13.3</b>	Rigging (websites)	<b>90</b>

# 1 Safety

This document details general rigging practices appropriate to the entertainment industry, as they would apply to the rigging and rigging ready products of X-Line Advance product family from Electro-Voice. It is intended to familiarize the user with standard rigging hardware and techniques for suspending X-Line Advance loudspeaker systems overhead. Only persons with the knowledge of proper hardware and safe rigging techniques should attempt to suspend any sound systems overhead. Prior to suspending any X-Line Advance loudspeaker systems overhead, it is essential the user is familiar with the strength ratings, rigging techniques and special safety considerations outlined in this manual. The rigging techniques and practices recommended in this manual are, of necessity, in general terms to accommodate the many variations in loudspeaker arrays and rigging configurations. As such, the user is expressly responsible for the safety of all specific X-Line Advance loudspeaker array designs and rigging configurations as implemented in practice.

All the general rigging material contained in this manual is based on the best available engineering information concerning materials and practices, as commonly recognized in the United States, and is believed to be accurate at the time of original printing. As such, the information may not be directly applicable in other countries. Furthermore, the regulations and requirements governing rigging hardware and practices may be superseded by local regulations. It is the responsibility of the user to make sure any Electro-Voice loudspeaker system is suspended overhead in accordance with all current federal, state, and local regulations.

All specific material concerning the strength ratings, rigging techniques, and safety considerations for the X-Line Advance loudspeaker systems is based on the best available engineering information concerning the use and limitations of the products. Electro-Voice continually engages in testing, research and development of its loudspeaker products. As a result, the specifications are subject to change without notice. It is the responsibility of the user to make sure that any Electro-Voice loudspeaker system is suspended overhead in accordance with the strength ratings, rigging techniques, and safety considerations given in this document and any manual update notices. Visit our website: [www.electrovoice.com](http://www.electrovoice.com) for current product technical documentation or software. All non-Electro-Voice associated hardware items necessary to rig a partial and/or a complete X-Line Advance loudspeaker array (chain hoists, building or tower supports, and miscellaneous mechanical components) are the responsibility of others.

Electro-Voice  
April 2019

## 1.1 Important safety instructions

1. Read these instructions.
2. Keep these instructions.
3. Heed all warnings.
4. Follow all instructions.
5. Clean only with a damp cloth. No harsh chemicals or solvents.
6. Do not install near any heat sources such as radiators, heat registers, stoves, or other apparatus (including amplifiers) that produce heat.

## 1.2 Suspension



### Warning!

Suspending any object is potentially dangerous and should only be attempted by individuals who have a thorough knowledge of the techniques and regulations of suspending objects overhead. Electro-Voice strongly recommends that loudspeakers be suspended taking into account all current national, federal, state, and local laws and regulations. It is the responsibility of the installer to ensure all loudspeakers are safely installed in accordance with all such requirements. When loudspeakers are suspended, Electro-Voice strongly recommends the system be inspected at least once per year or as laws and regulations require. If any sign of weakness or damage is detected, remedial action should be taken immediately. The user is responsible for making sure the wall, ceiling, or structure is capable of supporting all objects suspended overhead. Any hardware used to suspend a loudspeaker not associated with Electro-Voice is the responsibility of others.

## 1.3 Precautions

	These Electro-Voice loudspeakers were designed for use in an environment with ambient temperatures between -20°C (-4°F) and +50°C (122°F).
	These Electro-Voice loudspeakers are not rated for continuous outdoor conditions. However, they may be exposed to occasional short-term rain, water, or high humidity.
	Electro-Voice loudspeakers are easily capable of generating sound pressure levels sufficient to cause permanent hearing damage. Caution should be taken to avoid prolonged exposure to sound pressure levels exceeding 90 dB.

## 1.4



### Notices

#### Old electrical and electronic appliances

Electrical or electronic devices that are no longer serviceable must be collected separately and sent for environmentally compatible recycling (in accordance with the European Waste Electrical and Electronic Equipment Directive).

To dispose of old electrical or electronic devices, you should use the return and collection systems put in place in the country concerned.

**Copyright and disclaimer**

All rights reserved. No part of this document may be reproduced or transmitted in any form by any means, electronic, mechanical, photocopying, recording, or otherwise, without the prior written permission of the publisher. For information on getting permission for reprints and excerpts, contact Electro-Voice.

All content including specifications, data, and illustrations in this manual are subject to change without prior notice.

## 2 Short Information

The following table lists products in a family, with CTN (Commercial Type Number) and identifying product name DESCRIPTION.

CTN	DESCRIPTION
X1-212/90	X1 compact 2-way 1X12-in. 90° line array
X1-212/120	X1 compact 2-way 1X12-in. 120° line array
X2-212/90	X2 HP compact 2-way 1X12-IN 90° line array
X2-212/120	X2 HP compact 2-way 1X12-in. 120° line array
X12-125F	X12 1-way 2X15-in. flying sub, line array
X12-128	X12 1-WAY 2X18-IN NON-FLYING SUB
X12TC-GRID	Compact grid for X1/X2 tops
X12TE-GRID	Extended grid for X1/X2 tops
X12PU-BGK	Pull up bottom grid kit for X1/X2 tops
X12-125F-GRID	Grid for X12-125F subwoofers
X12-125F-AG	Grid adapter for X1/X2 to X12-125F
X12-125FPU-BGK	Pull up grid kit for X12-125F
X12-125F-CGK	Grill kit X12-125F as cardioid element
X12T-DOLLY	Dolly for X1/X2, 6 tops per dolly
X12-125F-DOLLY	Dolly for X12-125F flying subwoofers
X12-125F-DAK	Adapter kit, X12-125F-DOLLY to X1/X2
X12-125F-DOK	Outrigger kit for X12-125F-DOLLY
X12-128-DOLLY	Dolly for X12-128 non-flying subwoofers



### 3 System overview

Each X1-212/90 full-range element consists of one SMX2121 12-inch (304.8 mm) LF driver coupled to a Mid Band Hydra (MBH) and two ND2R 2-inch-diaphragm (50.8 mm) HF drivers. Each HF driver is mounted on a Wavefront-shaping Circular Hydra (WCH) planar-wave generator orientated vertically.

X1 is designed in a two-way configuration with a 90° horizontal x 10° vertical coverage pattern and an internally selectable passive crossover/EQ network. The enclosure is trapezoidal in the vertical plane with a 10° total included angle.

Each X2-212/90 full-range element consists of one DVN3125 12-inch (304.8 mm) LF driver coupled to a MBH and two ND6A 3-inch-diaphragm (76.2 mm) HF drivers. Each HF driver is mounted on a Pin Diffraction Hydra (PDH) planar-wave generator and vertically orientated. X2 is designed in a two-way configuration with a 90° horizontal x 10° vertical coverage pattern for bi-amp use only. A passive crossover/EQ network is neither included nor available. The enclosure is trapezoidal in the vertical plane with a 10° total included angle.

Each X1-212/120 full-range element consists of one SMX2121 12-inch (304.8 mm) LF driver coupled to a MBH and two ND2R 2-inch-diaphragm (50.8 mm) HF drivers. Each HF driver is mounted on a WCH planar-wave generator vertically orientated.

X1 is designed in a two-way configuration with a 120° horizontal x 10° vertical coverage pattern and an internally selectable passive crossover/EQ network. The enclosure is trapezoidal in the vertical plane with a 10° total included angle.

Each X2-212/120 full-range element consists of one DVN3125 12-inch (304.8 mm) LF driver coupled to a MBH and two ND6A 3-inch-diaphragm (76.2 mm) HF drivers. Each HF driver is mounted on a PDH planar-wave generator orientated vertically.

X2 is designed in a two-way configuration with a 120° horizontal x 10° vertical coverage pattern for bi-amp use only. A passive crossover/EQ network is neither included nor available. The enclosure is trapezoidal in the vertical plane with a 10° total included angle.

The X12-125F dual-15-inch subwoofer includes two HWNS4158 woofers designed specifically for subwoofer applications, providing reliable low-frequency performance at high SPL levels with low distortion and solid impact. Subwoofer elements do not have internal passive crossovers and require an active crossover and dedicated amplifier channel or channels for proper operation.

X12-125F is a vertically trapezoidal dual-15-inch subwoofer element designed specifically for use in flown arrays as either a high impact low frequency array or dedicated subwoofer array. Subwoofer arrays may be deployed in either conventional (front-firing) or cardioid configuration either flown or ground stacked on the X12-125F-DOLLY .

The X12-128 dual-18-inch subwoofer includes two DVF4180 woofers designed specifically for subwoofer applications, providing reliable low-frequency performance at high SPL levels with low distortion and solid impact. Subwoofer elements do not have internal passive crossovers and require an active crossover and dedicated amplifier channel(s) for proper operation.

X12-128 is a compact rectangular dual-18-inch subwoofer element designed for use only as a ground stack subwoofer array. It may be configured in multiple subwoofer array configurations, including cardioid, end fired and others.

All X-Line Advance elements are available in black and, except for the X12-128 subwoofer, are supplied with the hardware necessary to interface one element to another.

### **Accessories:**

#### **Grids**

The X-Line Advance grid options are sold separately. Consult Electro-Voice line array configuration software for proper grid selection and array design.

X12TC-GRID: Standard compact grids for up to 24 X1 or X2 elements for simple or mostly straight arrays, where extreme tilt angles are not required.

X12TE-GRID: Extended grids for up to 24 X1 or X2 elements for extreme down angles in small to medium arrays and typical up or down angles in large arrays.

X12PU-BGK: Pull up bottom grid kit for X1 or X2 elements. A pull-up kit is used when the compression rigging method is being used with an array or when extreme down angles beyond the capabilities of the extended grid are required.

X12-125F-GRID: Subwoofer grid is appropriate for subwoofer arrays where extreme up or down angles are not required. It is rated for a maximum hang of up to 18 X12-125F subwoofers in a single column. Use Electro-Voice line array configuration software to determine if X12-125F-GRID combined with the number of subwoofer elements will achieve the acoustical coverage in the venue at a safe working load.

X12-125F-AG: Adapter grid to attach up to nine X1 or X2 loudspeakers (depending on the array configuration) under X12-125F subwoofer as a mixed flown array.

X12-125FPU-BGK: Pull up bottom grid kit for X12-125F elements. A pull-up kit is used when the compression rigging method is being used with an array or when extreme down angles beyond the capabilities of the extended grid are required.

X12-125F-CGK: Cardioid grille kit may be used to hide the back of the X12-125F subwoofer when it faces the audience in a cardioid subwoofer group.

#### **Dollies**

The X-Line Advance dolly options are sold separately.

X12T-DOLLY is used for transporting X1 or X2 loudspeaker systems. The dolly accommodates two columns of X1 or X2 elements stacked three high for transportation (a total of six systems per dolly). Systems are secured to the dolly via their rigging. A rigid top cover provides a solid surface for stacking and two dolly side panels provide protection for speaker grilles. The dolly may also be used as a wheeled ground stack platform or the dolly cover as a stationary ground stack platform.

X12-125F-DOLLY is used for transporting X12-125F subwoofers. The dolly will accommodate one column of X12-125F subwoofers stacked two high when both subwoofers are facing forward or three high when in cardioid configuration (two forward facing and one backward facing) for transportation. The subwoofers are secured by the integrated rigging system for additional protection during transport. The X12-125F-DOLLY top cover is designed to accept the X12-125F-DAK dolly adapter kit which allows a small mixed array of X1 or X2 loudspeakers and X12-125F subwoofers to be assembled as a ground stack.

---

X12-125F-DOK dolly outrigger kit is used as a ground stack stabilizer for the X12-125F-DOLLY when the X12-125F-DAK dolly adapter kit is used to convert the top cover of the X12-125F-DOLLY into a mounting platform for X1 or X2 loudspeakers assembled as a small ground stack mixed array with X12-125F subwoofers.

**Caution!**

When ground stacking mixed arrays of X1 or X2 loudspeakers and X12-125F subwoofers, one or more X12-125F-DOK outrigger kits must be used.

Failure to properly deploy outriggers may result in property damage and personal injuries.

---

X12-128-DOLLY is used for transporting X12-128 subwoofers. The dolly will accommodate one column of X12-128 subwoofers stacked two high for transportation. The systems should be secured with ratchet straps (included) for additional protection during transport.

## 4 Designing an X-Line Advance speaker system array

### 4.1 Applications for which X-Line Advance arrays are most appropriate

The X-Line Advance loudspeaker systems were specifically designed to construct acoustically coherent line-arrays. Line-array systems typically consist of independent columns of loudspeaker enclosures. The most common implementation is a sound reinforcement system with two columns (left and right). Additional columns are sometimes added to cover different seating sections of a venue, for example, seating areas that wrap around the side or back of a stage. An additional column may be added for left-center-right configurations, with the center channel used for speech. Where multiple hangs are not required, sufficient coverage may be obtained with a single mono array. Multiple arrays may be employed in distributed systems in large venues such as arenas and stadiums.



#### Notice!

The X1 and X2 line arrays, even though mechanically identical, are not designed acoustically to work in the same column.

The quantity of X-Line Advance loudspeaker elements in a column and the relative vertical angles between them will vary depending on the vertical acoustic coverage and SPL requirements for a specific venue. The quantity of loudspeaker columns and the relative horizontal angles between them will also vary depending on the horizontal acoustic coverage requirements for the venue. Furthermore, loudspeaker elements having different coverage angles may be chosen within each column to further tailor the horizontal acoustic coverage.

### 4.2 Electro-Voice line array configuration software

Acoustic design techniques are outside the scope of this document. For acoustic design assistance, the reader is directed to the Electro-Voice line array configuration software available for download from the Electro-Voice website [www.electrovoice.com](http://www.electrovoice.com). This software will guide the user through design considerations to make the best choice of loudspeakers and loudspeaker array configurations for a specific venue application.

The Line Array Prediction Software versions LAPS 3.3.7 and earlier only support the following X-Line Advance products:

- X1-212/90
- X1-212/120
- X2-212/90
- X2-212/120
- X12-128
- X12TC-GRID
- X12TE-GRID
- X12PU-BGK
- X12T-DOLLY

Subsequent versions of the line array configuration software support all of the X-Line Advance products described in this document.

## **5 Preparing X-Line Advance elements for installation**

### **5.1 Unpacking and inspection**

Carefully open the packaging and take out the loudspeaker. Inspect the loudspeaker's enclosure for any damage that might have happened during transportation. Each loudspeaker is examined and tested in detail before leaving the manufacturing site. Please inform the transport company immediately if the loudspeaker shows any damage. Being the addressee, you are the only person who can claim damages in transit. Keep the cardboard box and all packaging materials for inspection by the transport company.

Keeping the cardboard box including all packing materials is also recommended, even if the loudspeaker shows no external damage.

When shipping the loudspeaker, make sure to always use its original box and packaging materials. By packing the loudspeaker exactly as it was packed by the manufacturer, you will guarantee optimum protection from transport damage.

### **5.2 Scope of delivery**

Keep the original invoice that states the purchase/delivery date in a safe place.

### **5.3 Recommended preflight procedures**

For any sound system, certain checks made at the installer's place of business can prevent expensive on-site delays. A short-list follows, and sets the stage for proper array performance:

1. Unpack all loudspeakers in the shop.
2. Check for proper model numbers.
3. Check the overall condition of the loudspeakers.
4. Check for continuity at the loudspeaker inputs.

It is a good idea, once on-site and the loudspeakers are connected, to check again for continuity at the power-amplifier end.

### **5.4 Element configuration**

After using Electro-Voice line array configuration software to design an appropriate array, it is recommended all necessary hardware and accessories to suspend the array are checked and accounted for. Ensure all hardware is in good working order, no defects, damage or imperfections are present, and all hardware is capable of meeting or exceeding the total load requirements of the entire array.

## 6 Rigging system

### 6.1 Overview of the flying system

The Integrated Rigging System (IRS) on X-Line Advance loudspeaker systems was developed as a faster, safer way of flying, aiming and landing a large vertical array.

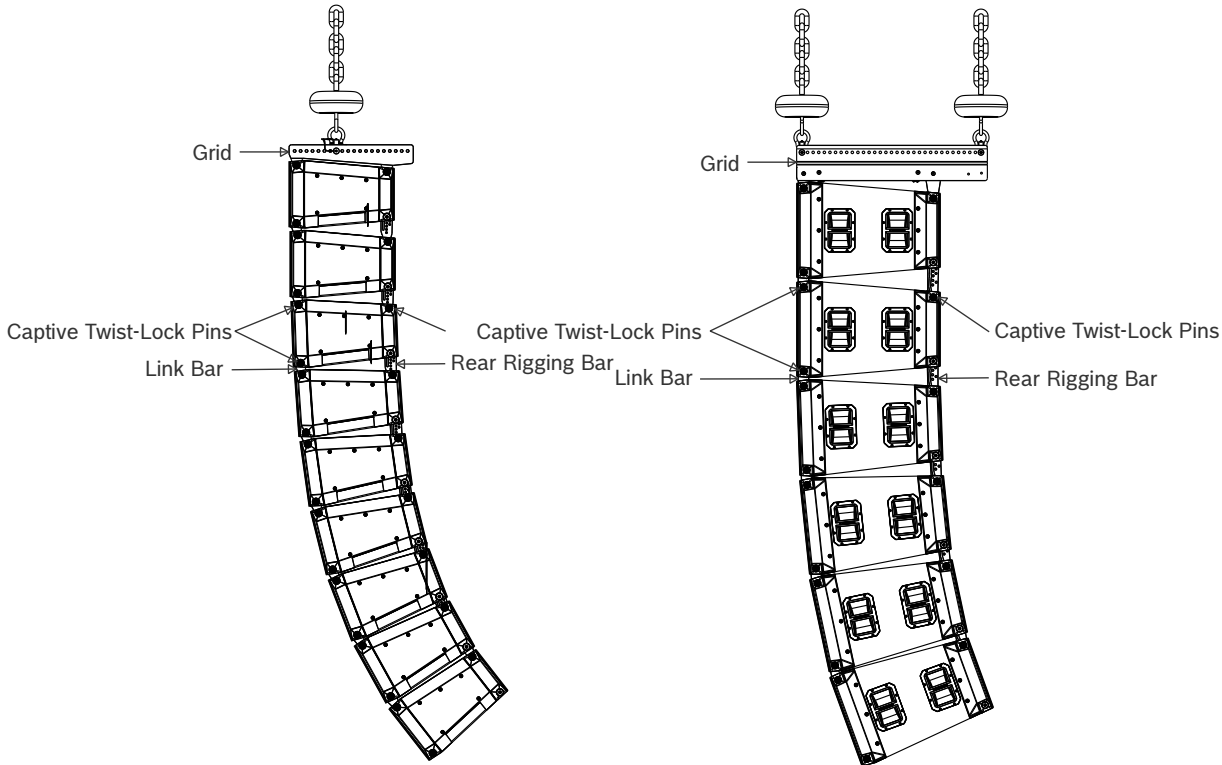


Figure 6.1: Integrated Rigging System

### 6.2 Rigging the elements together

The X1/X2 full-range elements and the X12-125F flying subwoofer are designed with the same rigging concept.

The individual elements are fastened together by spring-loaded captive twist lock pins. The captive twist lock pins are located at each of the four upper corners and two lower front corners of each element. The upper pins attach each element to the extended link bars of the element above it or to a grid. The pins can be locked in their retracted (open) position by grasping each pin knob and pulling out as far as it will go, then turning the knob left or right. The link bars of the element or grid above can then be dropped safely into the V-blocks located at the top corners of the aluminum rigging. There is no fumbling for pin holes because alignment is accomplished by the V-blocks. Once seated, the pins are engaged by simply twisting each knob to unlock, allowing the spring to fire the pin into position. Lower front link bars are released or retracted and locked into position the same way. Rear link bars are set to the desired splay angle position with standard quick-release pins.



#### Notice!

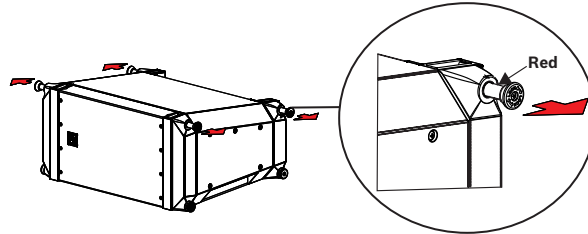
In this section, the rigging steps illustrated with X1/X2 full-range drawings are performed the same way for the X12-125F subwoofer. Rigging differences between the X1/X2 full-range elements and the X12-125F subwoofer are noted in the steps, when applicable.

**Notice!**

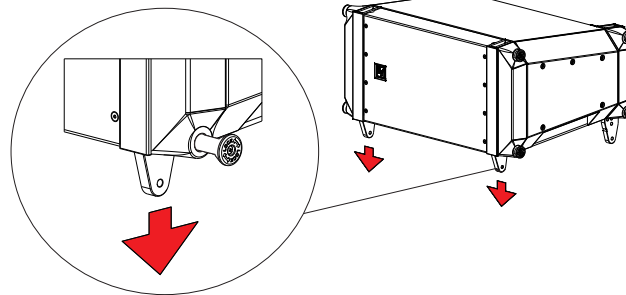
Before flying the array, make sure that all captive twist lock pins are fully engaged in the rigging (no red showing between the pin knob and the element).

To rig the elements together, do the following:

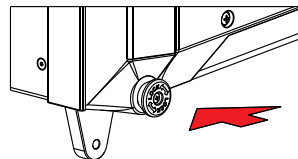
1. Pull and twist four captive twist lock pins on the top of the lower enclosure.  
Four captive twist lock pins are locked in the retracted (open) position.



2. Repeat for the two front link bars on the bottom of the upper enclosure.



3. Return the two captive twist-lock pins on the front link bars to the engaged (closed) position.



4. Extend and pin the rear link bars.
5. Guide the link bars of the element or grid above into the V-blocks located at the top corners of the aluminum rigging.
6. Twist the four captive twist-lock pins on top of the lower enclosure to return them to the engaged (closed) position.

## 6.3 Setting rear link angles

This section provides the steps to set rear link angles for the X1/X2 full-range elements and the X12-125F flying subwoofer.

The rear link angle is selected by choosing corresponding holes in the white ANGLE SELECT sections of the rear rigging on each side as determined by the Electro-Voice line array configuration software. Unless the rigging is locked into a rigid configuration by secondary pins in the lower black ANGLE LOCK sections, the elements always default to 0° when lifted. Use of the bottom pull-up grid accessory enables the array to be easily compressed with each element stopping at its pre-selected splay angle. Smaller arrays may be rigidly pinned by lifting the rear of each element until it hits the pre-selected angle stop, then inserting a second pin on each side into the appropriate hole in the ANGLE LOCK section. There should be no fumbling for pin holes because when lifted, the rigging will stop at the pre-selected position.

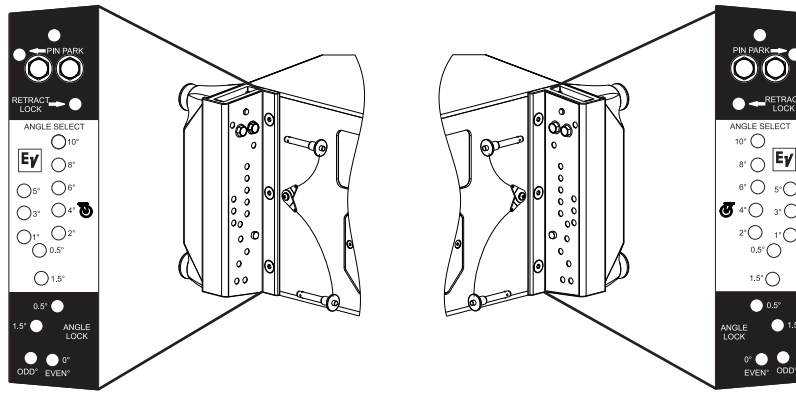


Figure 6.2: X1/X2 rigging hardware

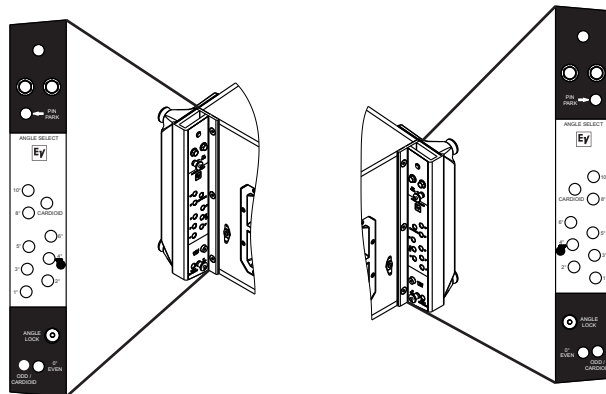


Figure 6.3: X12-125F rigging hardware

Rear link angle selection

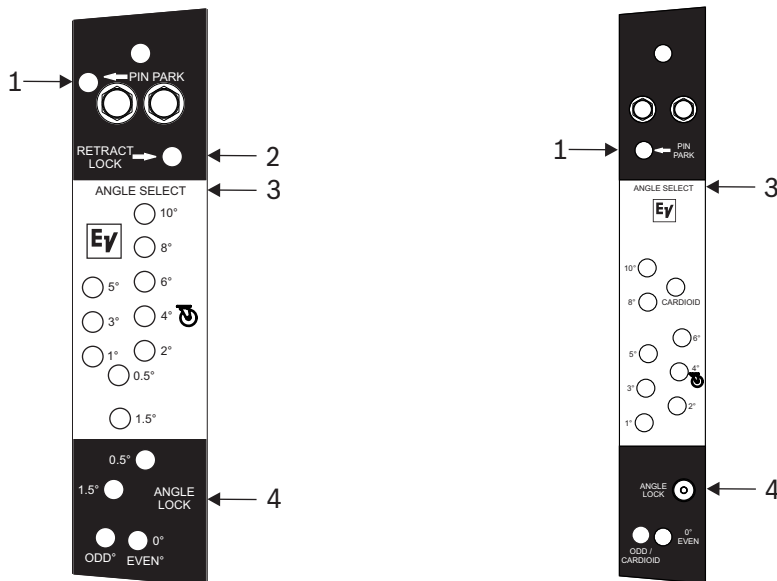


Figure 6.4: X1/X2 full-range (left) and X12-125F (right) link angle labels

1. **PIN PARK** is used to store or park the unused pin when an angle is not set for the element.
2. **RETRACT LOCK** is used to lock the link bar in the stored position. (X1 or X2 full-range only)



3. **ANGLE SELECT** (in the white section) is used to set the desired splay angle from the report in the line array configuration software. This is used for both fixed-pin angles and rear-rigging compression pull-up.
  - X1 or X2 full-range available angles are: **0.5, 1°, 1.5, 2°, 3°, 4°, 5°, 6°, 8°, and 10°**. For a 0° angle, use the 0° angle hole in the Angle Lock section.
  - X12-125F available angles are: **1°, 2°, 3°, 4°, 5°, 6°, 8°, CARDIOID and 10°**. For a 0° angle, use the 0° angle hole in the Angle Lock section.
  - **DOLLY WHEEL** (the 4° hole) is used to secure the bottom element of a stack to a dolly.
  - **CARDIOID** angle selection is only used when a cardioid subwoofer block is being suspended or ground stacked (X12-125F only).
4. **ANGLE LOCK** is used to lock the rear link bar for fixed-pinned angles. Except for a 0° angle, this section is not used for rear-rigging compression pull up.
  - **0.5° and 1.5°** are used to lock those two angles. (X1 or X2 full-range only)
  - **ODD°** is used to lock the odd number angles. (X1 or X2 full-range only)
  - **ODD/CARDIOID** is used to lock the odd number angles or the angles for a cardioid subwoofer block. (X12-125F only)
  - **0° EVEN°** is used to lock the even number angles and the 0° angle.

### 6.3.1

#### Single pin and double pin

Single pin compression method is used when a pull-up to the grid is employed to pull the rear rigging together into compression. Double pin is used to set the rear rigging at fixed angles. Make sure both sides of the element are pinned identically.

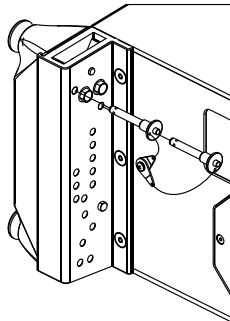


#### Notice!

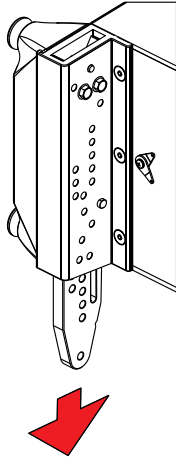
In this section, the rigging steps illustrated with X1/X2 full-range drawings are performed the same way for the X12-125F subwoofer. Rigging differences between the X1/X2 full-range elements and the X12-125F subwoofer are noted in the steps, when applicable.

To single pin or double pin, do the following:

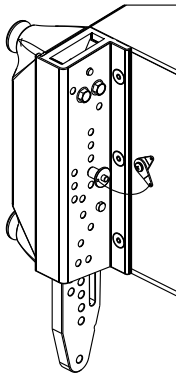
1. Release the quick-release pin from RETRACT LOCK hole.  
This step applies to the full-range X1/X2 loudspeakers.  
OR  
Release the quick-release pin from 0° EVEN hole.  
This step applies to the X12-125F subwoofer.



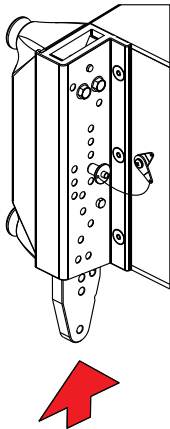
- Lift the element to take the weight off the rear link bars.



- Pull the angle lock pins.  
The rear link bars will then drop if they are not already fully extended.
- Insert a quick-release pin into the desired ANGLE SELECT degree hole on one side of the element.
- Insert a quick-release pin into the desired ANGLE SELECT degree hole on the other side of the element.
- Verify both pins are thoroughly pushed in and the blue button is not depressed.
- Make sure the same degree hole is selected on both sides.

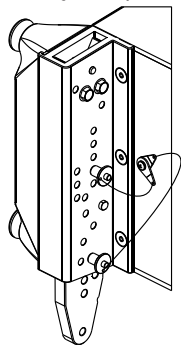


- If using double pin continue to the next step.
- Lower the element until its weight is resting on the angle select pins.



- Insert the second quick-release pin into desired ANGLE LOCK hole.

11. Verify the pin is pushed in all the way and the blue button is not depressed.



12. Insert a quick-release pin into the ANGLE LOCK hole on the other side of the element.
13. Verify both pins are pushed in all the way and the blue buttons are not depressed.
14. Repeat this process on all elements in the array setting the angles per the report from Electro-Voice line array configuration software.

## 7 Transportation dollies

X12T-DOLLY is used for transporting X1 or X2 loudspeaker systems. The dolly accommodates two columns of X1 or X2 elements stacked three high for transportation (a total of six systems per dolly). Systems are secured to the dolly via their rigging. A rigid top cover provides a solid surface for stacking and two dolly side panels provide protection for speaker grilles. The dolly may also be used as a wheeled ground stack platform or the dolly cover as a stationary ground stack platform.

X12-125F-DOLLY is used for transporting X12-125F subwoofers. The dolly will accommodate one column of X12-125F subwoofers stacked two high when both subwoofers are facing forward or three high when in cardioid configuration (two forward facing and one backward facing) for transportation. The subwoofers are secured by the integrated rigging system for additional protection during transport. The X12-125F-DOLLY top cover is designed to accept the X12-125F-DAK dolly adapter kit which allows a small mixed array of X1 or X2 loudspeakers and X12-125F subwoofers to be assembled as a ground stack.

X12-125F-DOK dolly outrigger kit is used as a ground stack stabilizer for the X12-125F-DOLLY when the X12-125F-DAK dolly adapter kit is used to convert the top cover of the X12-125F-DOLLY into a mounting platform for X1 or X2 loudspeakers assembled as a small ground stack mixed array with X12-125F subwoofers.



### Caution!

When ground stacking mixed arrays of X1 or X2 loudspeakers and X12-125F subwoofers, one or more X12-125F-DOK outrigger kits must be used. Failure to properly deploy outriggers may result in property damage and personal injuries.

X12-128-DOLLY is used for transporting X12-128 subwoofers. The dolly will accommodate one column of X12-128 subwoofers stacked two high for transportation. The systems should be secured with ratchet straps (included) for additional protection during transport.

### Notice!

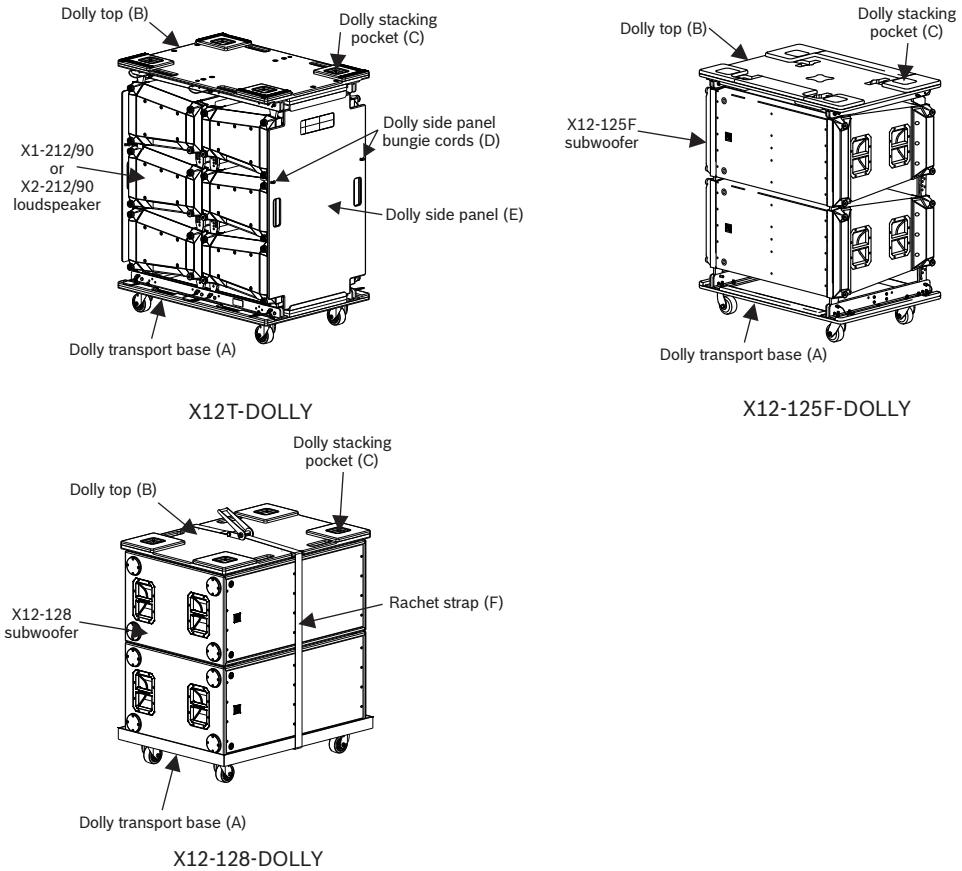
#### Dolly stacking limits

X12T-DOLLY accommodates two columns of X1 or X2 loudspeaker systems stacked three high for transportation. The dolly is designed for a total of six loudspeakers per dolly.

X12-128-DOLLY accommodates one column of X12-128 subwoofers stacked two high for transportation. The dolly is designed for a total of two subwoofers per dolly.

X12-125F-DOLLY accommodates one column of X12-125F subwoofers stacked two high when both subwoofers are facing forward or three high when in cardioid configuration (two forward facing and one backward facing) for transportation.





**Figure 7.1:** Transportation dolly options

A	Dolly transport base	B	Dolly top
C	Dolly stacking pocket	D	Dolly side panel bungie cords
E	Dolly side panel	F	Ratchet strap

## 7.1 Stacking X1, X2, and X12-125F elements onto a dolly



**Caution!**

We recommend that two or more persons lift and place heavier loudspeakers. Single person lift and placement of heavier loudspeakers could cause injury.



**Caution!**

When lifting a column of enclosures, make sure the correct dolly pins are released from the dolly base. There are four dolly pins for each stack on the dolly base. (A total of eight pins on the X12T-DOLLY base.)

If the column of enclosures is lifted with any of the dolly pins still locking the speakers to the base, the dolly base will lift and tip. Property damage and personal injuries may occur.



**Notice!**

**Dolly wheel (the 4° hole):**

The bottom element to be landed on the dolly base must be pinned in the 4° hole (⌚) in the ANGLE SELECT section. Compress the rear link bars until they contact the angle select pin and lock by adding a second pin in the EVEN holes of the ANGLE LOCK section. Ensure the two front link bars are lowered and locked.

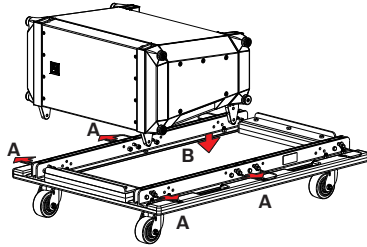


**Notice!**

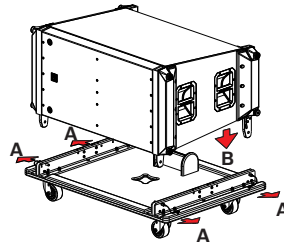
In this section, the rigging steps illustrated with X1/X2 full-range drawings are performed the same way for the X12-125F subwoofer. Rigging differences between the X1/X2 full-range elements and the X12-125F subwoofer are noted in the steps, when applicable.

To stack X1, X2, or X12-125F elements onto a dolly, do the following:

1. Release the four dolly pins (A) on the dolly.  
All four dolly lock pins are released and hanging from the dolly.

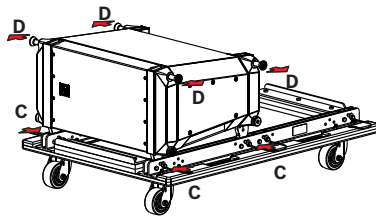


X12T-DOLLY

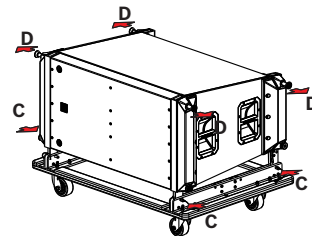


X12-125F-DOLLY

2. Extend and lock the two front link bars.
3. Extend and lock the two rear link bars at 4°.
4. Align the two front link bars over the V-blocks nearest the end of the dolly.
5. Guide the element (B) onto the dolly with the grille facing out.
6. Insert the four dolly pins (C) to lock the element onto the dolly.  
Ensure the four dolly pins are secure.

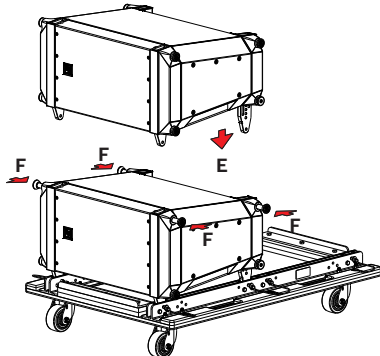


X12T-DOLLY

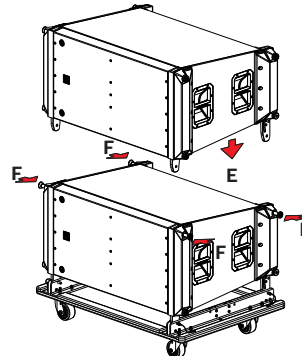


X12-125F-DOLLY

7. Pull and twist the four captive twist lock pins (D).  
All four captive twist lock pins should be in the retracted (open) position.
8. On the next element, extend and lock the two front link bars.
9. Extend and lock the two rear link bars at 0° EVEN.
10. Guide the next element (E) onto the stack.



X12T-DOLLY



X12-125F-DOLLY

11. Release the four captive twist-lock pins (F).  
All four captive twist-lock pins should now be in the closed position. Ensure the element is secure.
12. Repeat steps 7-11 to add up to three X1 or X2's in a single column.  
The next two steps apply to the X12T-DOLLY only.
13. Rotate the dolly.
14. Repeat steps 1-11 to stack the second column.



### Stacking a cardioid subwoofer array on the X12-125F-DOLLY

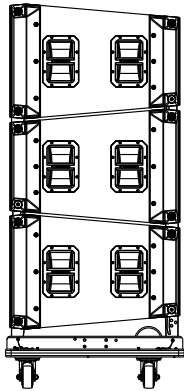


#### Warning!

During transportation of a cardioid subwoofer array it is recommended that two people maneuver the loaded dolly. The combined weight of a cardioid subwoofer array on the dolly will exceed 750lb (340 kg). It is possible for the array to tip over if the dolly is not handled properly.

Disregarding this warning could result in major injury or possibly death.

To build a 3-element cardioid array of X12-125F subwoofers, do the following:



#### Bottom element

1. Release the four dolly pins on the dolly.  
All four dolly lock pins are released and hanging from the dolly.
2. Lift the front of the element.
3. Pull and twist one of the front captive twist lock pins on the bottom element.  
The front link bar will extend.
4. Twist and lock the captive twist lock pin at the front of the element.  
The captive twist lock pin at the front of the element should now be in the closed position with the front link bar extended.

5. Repeat steps 2-4, on the other side of the element.
6. Identify the rear side of the dolly with the raised stop for the bottom element.
7. Orient the front side of the element with the front side of the dolly.
8. Guide the two front link bars into the V-blocks at the front of the dolly.
9. Insert the front dolly ball-detent pin on one side of the element.
10. Insert the front dolly ball-detent pin on the other side of the element.
11. Verify both ball-detent pins are thoroughly pushed into the dolly rail.
12. Lift the rear of the element to take the weight off the rear link bars.
13. Pull the angle lock pins.  
The rear link bars will then drop if they are not already fully extended.
14. Insert a quick-release pin into the ANGLE SELECT 4° hole (🔒) on one side of the element.
15. Insert a quick-release pin into the ANGLE SELECT 4° hole (🔒) on the other side of the element.
16. Verify both pins are pushed in all the way and the blue buttons are not depressed.
17. Lower the element until its weight is resting on the angle select pins.
18. Insert the second quick-release pin into the ANGLE LOCK hole 0° EVEN on one side of the element.
19. Insert the second quick-release pin into the ANGLE LOCK hole 0° EVEN on the other side of the element.
20. Verify both pins are pushed in all the way and the blue buttons are not depressed.
21. Insert the rear dolly ball-detent pin on one side of the element.
22. Insert the rear dolly ball-detent pin on the other side of the element.
23. Verify both ball-detent pins are pushed all the way through both dolly rails.

### **Adding elements 2 & 3**

1. Pull and twist the four upper captive twist lock pins on the previously stacked element.  
Make sure all four captive twist lock pins are in the open position.
2. On the next element, lift the front of the element.
3. Pull and twist one of the front captive twist lock pins on the element.  
The front link bar will extend.
4. Twist and lock the captive twist lock pin at the front of the element.  
The captive twist lock pin at the front of the element should now be in the closed position with the front link bar extended.
5. Repeat steps 2-4, on the other side of the element.
6. Pull the angle lock pins.  
The rear link bars will then drop if they are not already fully extended.
7. Insert a quick-release pin into the ANGLE SELECT CARDIOID hole on one side of the element.
8. Insert a quick-release pin into the ANGLE SELECT CARDIOID on the other side of the element.
9. Verify both pins are pushed in all the way and the blue buttons are not depressed.
10. Lower the element until its weight is resting on the angle select pins.
11. Insert the second quick-release pin into the ANGLE LOCK ODD/CARDIOID hole on one side of the element.
12. Insert the second quick-release pin into the ANGLE LOCK ODD/CARDIOID hole on the other side of the element.
13. Verify both pins are pushed in all the way and the blue buttons are not depressed.
14. Orient the next element to align the front with the rear of the previously installed element.



- The front of the next element is aligned with the rear of the previously installed element.
15. Align the extended link bars with the open V-blocks at the top four corners of the previously installed element.
  16. Guide the cardioid steering element onto the previously installed element.
  17. Twist and lock the four captive twist lock pins at the top of the previously installed element.
- All four captive twist lock pins are in the closed position. Ensure the element is secure.
18. Repeat steps 1-17, to add the third element in the stack.

#### Refer to

- *X12T-DOLLY side panels and top cover, page 25*
- *X12-125F-DOLLY top cover, page 26*
- *X12-125F-DOLLY accessories, page 27*
- *Ground stacking, page 33*
- *Storing empty dollies, page 59*
- *Landing arrays onto a dolly, page 60*

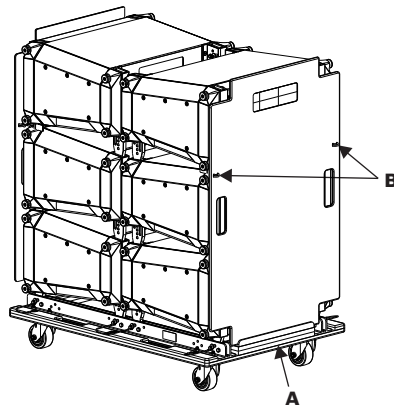
### 7.1.1

#### X12T-DOLLY side panels and top cover

##### Installing the dolly side panels

To install the dolly side panels, do the following:

1. Guide one dolly side panel into the dolly base between the two locking rails and the side panel guide (A) with the carpeted side facing the loudspeaker grilles.
2. Ensure the dolly side panel is aligned between the two locking rails and squared to the side panel guide with the scribble label at the top.



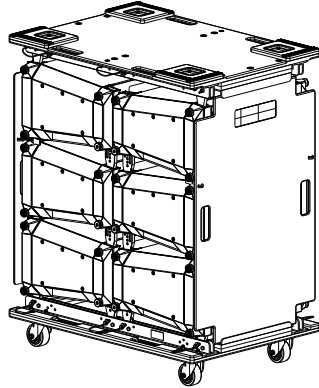
3. Secure the bungie cord (B) around the two nearest captive twist-lock pin heads on both edges of the cover.
4. Repeat steps 1-2 for the three remaining loudspeakers.

##### Installing the dolly top cover

To install the dolly top cover, do the following:

1. Pull and twist open the two captive twist lock pins by the grille on the top two loudspeakers.  
Ensure the top two captive twist lock pins are open on both loudspeakers on the stack.
2. Guide the link bars of the dolly top cover into the V-blocks of the loudspeaker rigging.

Ensure both dolly side panels are squared and inside all side panel guides.



3. Release the four captive twist-lock pins in the top cover link bars.  
All four captive twist-lock pins should now be in the closed position. Ensure the top dolly cover is secure.

### 7.1.2

#### X12-125F-DOLLY top cover



##### Notice!

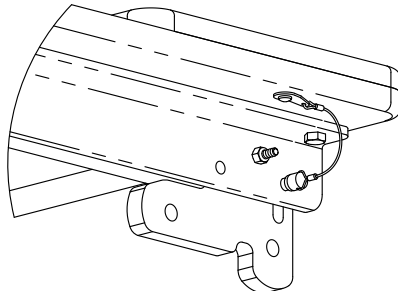
The dolly top cover comes with the dolly top cover rear link bars in the retracted (storage) position.

This position enables X12-125F dollies to be stacked flat for storage.

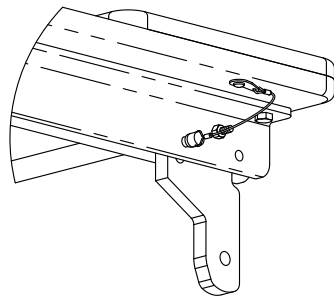
##### Preparing the top cover for installation

To prepare the top cover for installation, do the following:

1. On each side, pull the pin securing the rear link bar in the retracted (storage) position.



2. Slide the link bar to the rear.
3. Rotate the link bar  $\frac{1}{4}$  turn to the rear.
4. Slide the link bar as far forward as it will go
5. Insert the attached pin in the forward pin hole to secure the link bar in the extended position.

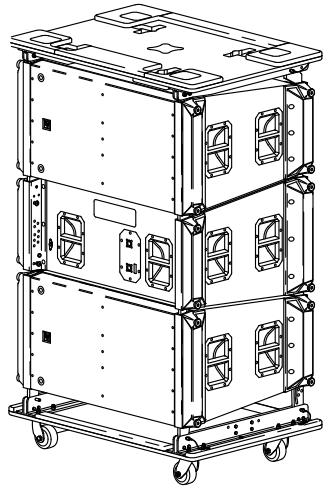


Reverse the process to return to the storage position.

### Installing the dolly top cover

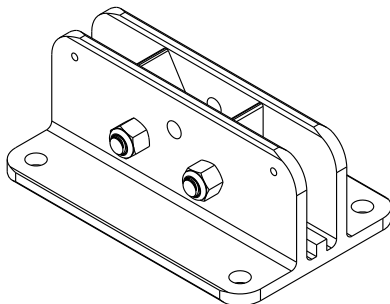
To install the dolly top cover, do the following:

1. Pull and twist open the four captive twist lock pins on the top subwoofer.-
  2. Verify the dolly top cover rear link bars are in the extended position.
  3. Align the dolly top cover with the top subwoofer.  
The short bars align with the grille side of the top subwoofer. The long bars align with the input panel side of the top subwoofer.
  4. Guide the extended link bars of the dolly top cover into the V-blocks of the top subwoofer.
  5. Twist and engage the four captive twist lock pins.
- All four captive twist lock pins are in the closed position. Ensure the dolly top cover is secure.



## 7.2 X12-125F-DOLLY accessories

### 7.2.1 Installing the X12-125F-DAK dolly adapter kit onto the top cover of the X12-125F-DOLLY



**Figure 7.2:** X12-125F-DAK Dolly Adapter Kit

**Tools needed:**

- One 5/32" Hex (Allen) key
- One 9/16" wrench
- One 9/16" deep well socket wrench

Ensure all of the parts in this X12-125F-DAK dolly adapter kit are present and accounted for.

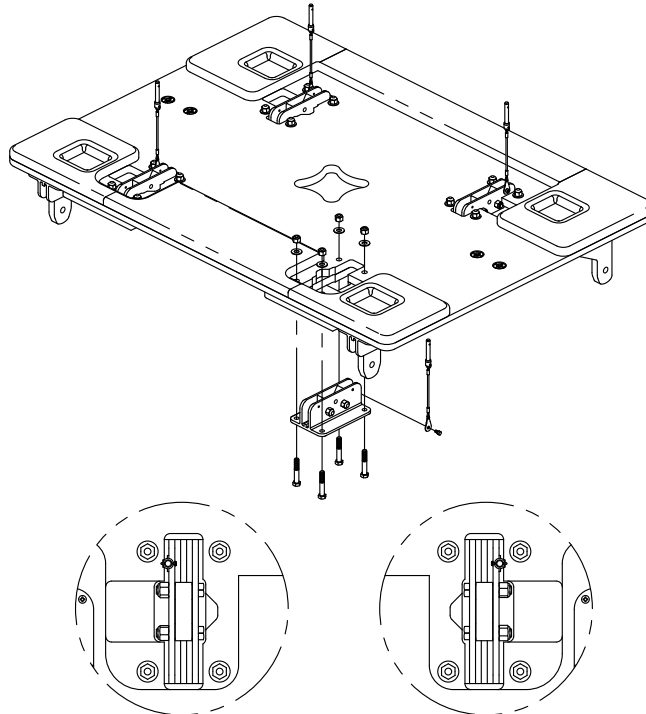
**Caution!**

Install with non-powered tools only. Do not use an impact driver. Do not over tighten the bolts and nuts. Bolts and nuts are properly tightened when the washers under the nuts are just beginning to sink into the wood.

Further tightening the bolts and nuts will only crush the wood.

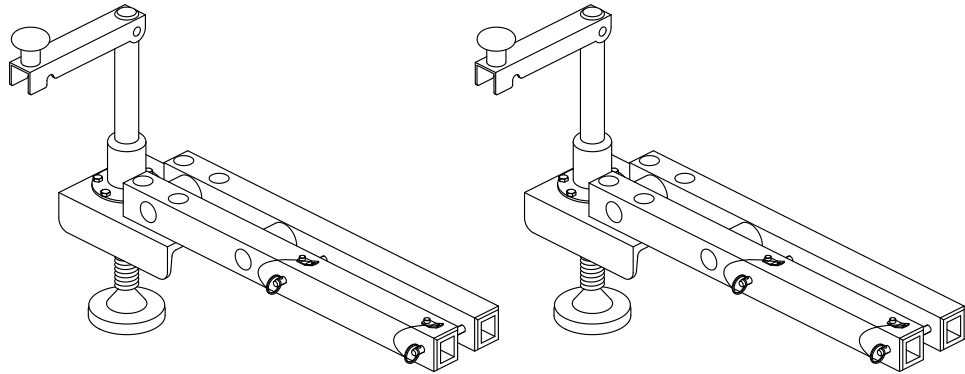
To install the X12-125F-DAK dolly adapter kit, do the following:

1. Insert one X12-125F-DAK ground stack block assembly into one of the cut-outs in the dolly top cover from the underside of the cover.  
See the illustration for proper orientation.



2. Thread four 3/8-16 hex head bolts up through the holes in the base of the block until the bolts are fully seated in the base of the block and the threads are protruding up through the top surface of the dolly.
3. Place a washer over each protruding bolt thread and start a nylon locking nut.
4. Finger tighten the four nylon locking nuts.
5. Using a 9/16" wrench to hold the bolt heads and a 9/16" deep well socket to turn the nuts, gradually tighten the four nuts and bolts in a crisscross pattern until the washers under the nuts just begin to sink into the wood.  
This is sufficient for maximum strength. Do not over tighten.
6. Using one #10-24 hex socket head cap screw, secure one pin and lanyard assembly to one of the tapped holes in the ground stack block.  
A dab of thread locker may be used, if desired, to prevent this screw from loosening.  
Tighten until snug with a 5/32" hex (Allen) key. Do not over tighten.
7. Repeat steps 1-6 for the three remaining X12-125F-DAK ground stack block locations.  
The X12-125F-DAK ground stack kit does not interfere with normal operation of the dolly and may be left installed permanently.

## 7.2.2

**Assembling an X12-125F-DOK dolly outrigger kit to an X12-125F-DOLLY****Figure 7.3:** X12-125F-DOK Dolly Outrigger Kit**Warning!**

Ensure the dolly base is level and there is contact to the ground or floor at all four corners. The points of contact must be on a hard surface capable of supporting the weight. A ground-stacked array that is not solidly supported may topple over, causing property damage or personal injury.

**Caution!**

If working on uneven ground, we recommend that two people install the X12-125F-DOK. One person should be in control of the loaded dolly while the other person installs the X12-125F-DOK.

A loaded dolly rolling out of control could cause property damage or personal injury.

**Notice!**

Use X12-125F-DOK outriggers in pairs on the front or back side of dolly ONLY.

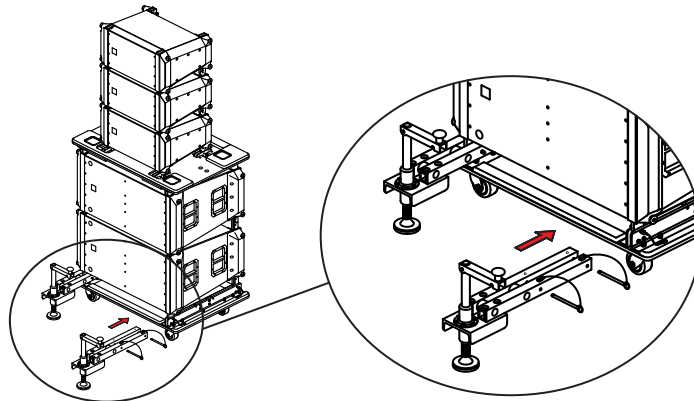
Two X12-125F-DOK outrigger kits (four outriggers) may be installed on the same X12-125F-DOLLY for added stability or leveling.

For maximum acoustical performance and to ensure safety, design your ground stacked array using Electro-Voice line array configuration software. Consult Electro-Voice line array configuration software to determine if outriggers are needed and whether the outriggers need to be added to the front or back of the dolly. Always use both outrigger assemblies on the same side (front or back) of the X12-125F-DOLLY.

To assemble an X12-125F-DOK outrigger kit to an X12-125F-DOLLY, do the following:

1. Determine if you need to install the X12-125F-DOLLY outrigger kit to the front or back side of the X12-125F-DOLLY.

2. Pull one ball-detent pin from the dolly rails of the X12-125F-DOLLY where the first outrigger of the X12-125F-DOK outrigger kit is to be attached.



3. Pull the ball-detent pin from the dolly rails where the second outrigger of the X12-125F-DOK outrigger kit is to be attached.
4. Pull the first long ball-detent pin from the X12-125F-DOK outrigger assembly.
5. Pull the second ball-detent pin from the X12-125F-DOK outrigger assembly.
6. Fully retract the jack screw floor pad of the outrigger.
7. Slide one of the outrigger assemblies onto the dolly so that it straddles the rails at one end of the dolly.
8. Slide the outrigger in until the spacer block on the outrigger touches the end of the dolly rails.
9. Back the outrigger assembly slightly away from the end of the dolly rails.
10. Insert one of the long ball-detent pins attached to the outrigger through the front pin hole on the outer outrigger bar.
11. Make sure the ball-detent pin is inserted all the way through the dolly rails, subwoofer rigging link bar and out the back side of the opposite outrigger bar. The short ball-detent pin attached to the dolly in this location is not used while the outrigger assembly is in place.
12. Pivot the outrigger assembly on the newly installed front ball-detent pin until it is parallel with the dolly rails.
13. Insert the remaining attached long ball-detent pin into the remaining pin hole of the outer outrigger bar.
14. Push it all the way through the corresponding pin holes in the dolly rails and out the back side of the opposite outrigger bar.
15. Make sure both long pins are fully inserted through both outrigger bars and dolly rails.
16. Repeat steps 2 thru 14 for the remaining outrigger assembly.
17. Verify the short ball-detent pins securing the subwoofer link bars to the dolly rails on the side of the dolly opposite the outriggers are fully inserted.

## 7.3

### Stacking X12-128 subwoofers onto a X12-128-DOLLY

#### Warning!



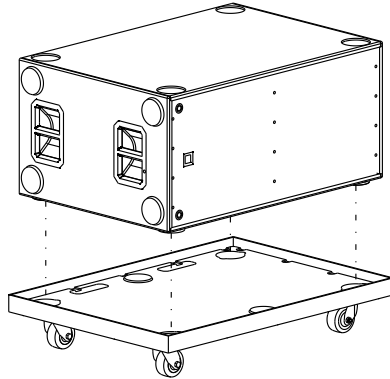
During transportation of X12-128 subwoofers, you must secure the loudspeakers to the dolly with the provided ratchet strap. We recommend that two people maneuver the loaded subwoofer dolly. Two X12-128 subwoofers with the dolly will exceed 450 lb (204 kg). It is possible for the subwoofers to tip over if the dolly is not handled properly. Disregarding this warning could result in major injury or possibly death.

**Caution!**

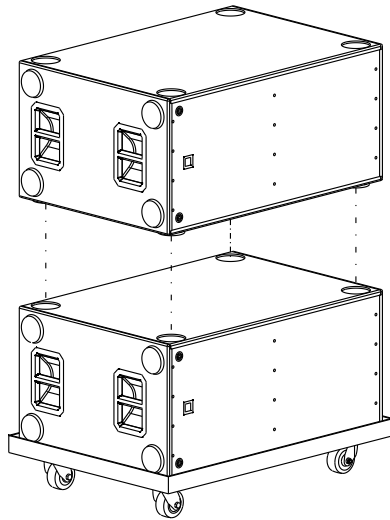
We recommend that two or more persons lift and place heavier loudspeakers. Single person lift and placement of heavier loudspeakers could cause injury.

To stack X12-128 subwoofers onto a dolly, do the following:

1. Guide one subwoofer onto the dolly.  
The plastic feet on the bottom of the subwoofer drop into the corresponding recesses in the dolly base.



2. Guide a second subwoofer onto the stack.  
Mate the plastic feet of the top subwoofer into the recesses on the top of the base subwoofer.

**Refer to**

- *Ground stacking subwoofers, page 33*
- *Storing empty dollies, page 59*

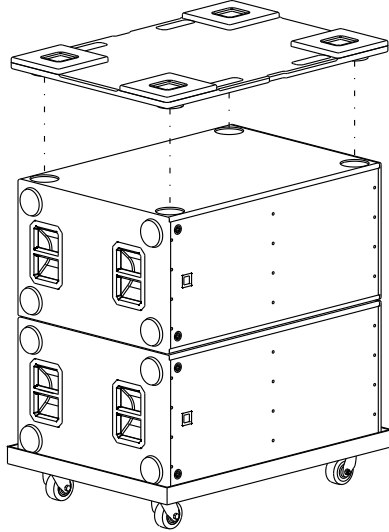
### 7.3.1

## X12-128-DOLLY top cover and ratchet strap

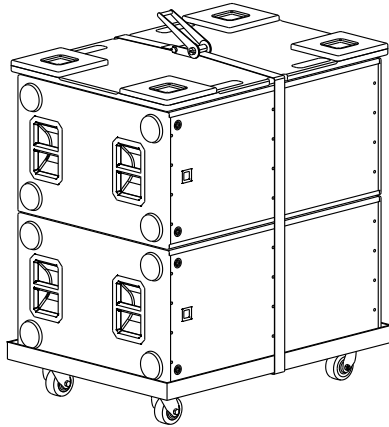
### Installing the dolly top cover and ratchet strap

To install the dolly top cover and ratchet strap, do the following:

1. Place the dolly top onto the stack, mating the plastic feet on the cover with the recesses on top of the subwoofer.



2. Run the ratchet strap under the dolly.  
Make sure ratchet strap is flat against the subwoofers and not twisted.
3. Align the ratchet strap in the strap cutout on the dolly top.
4. Tighten the ratchet strap.  
Dolly contents now are secured for transport.





## 8 Ground stacking



### Warning!

Ensure the dolly base is level and there is contact to the ground or floor at all four corners. The points of contact must be on a hard surface capable of supporting the weight. A ground-stacked array that is not solidly supported may topple over, causing property damage or personal injury.



### Warning!

Do not climb on the array. The combined weight of the array plus a person may shift the center of gravity of the array enough to cause it to topple over.

A ground stacked array that is not level and evenly supported may topple over, causing property damage, personal injury or death.

### 8.1 Ground stacking X1/X2 loudspeakers

The dolly top is designed to be used as a ground-stacking kit. Maximum recommended ground stack height is six elements.

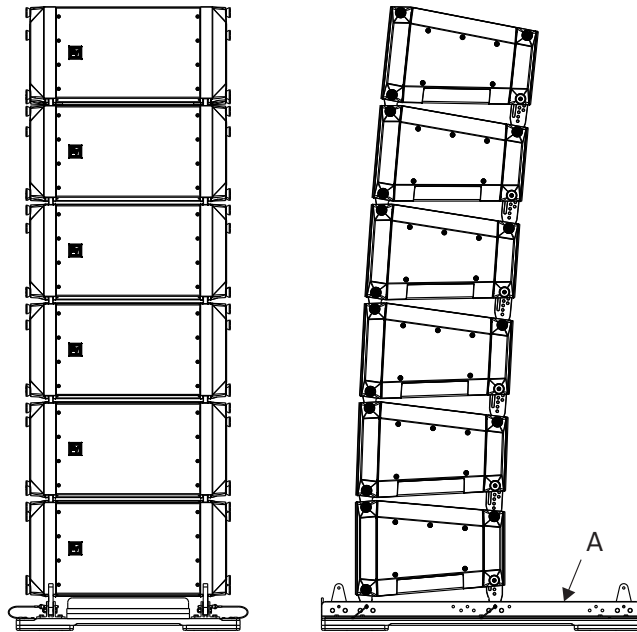


Figure 8.1: X1 or X2 ground stacking on a dolly top (A)

### 8.2 Ground stacking subwoofers

X-Line Advance subwoofers are designed for multiple configurations. They may be used as a forward facing standard array or as a cardioid array. On the input panel, you have a choice to connect the subwoofer in either parallel (4 ohm) or dual (8 ohm) mode for optimum subwoofer array control.

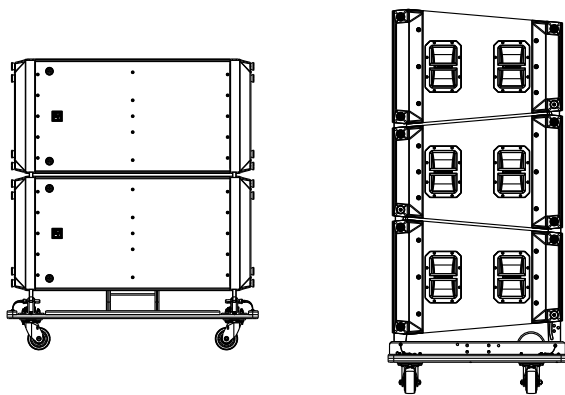


Figure 8.2: X12-125F ground stacking array; forward facing (left), cardioid (right)

### 8.2.1 Subwoofer array configuration



**Notice!**

All cardioid arrays require special processing and separate amplifier channels for the front facing and rear facing elements.

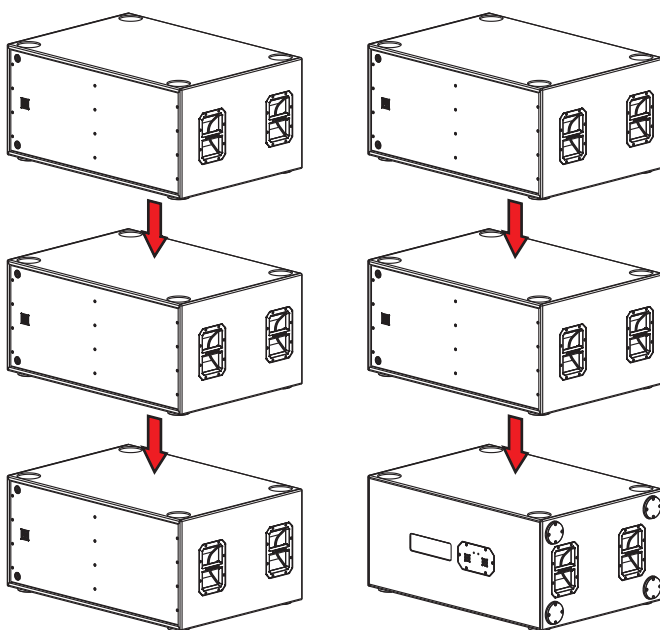
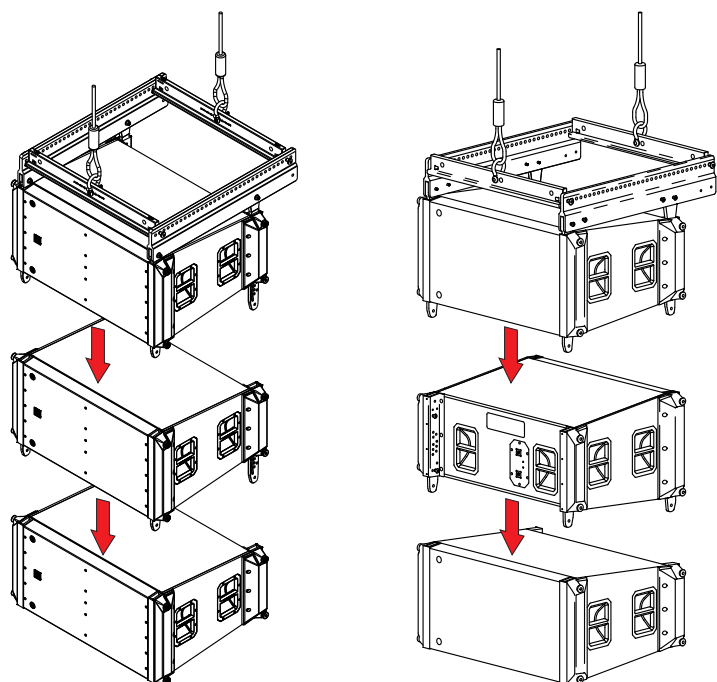


Figure 8.3: X12-128 forward (left), cardioid (right)



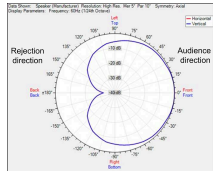
**Figure 8.4:** X12-125F forward (left), cardioid (right) with X12-125F-GRID

### 8.2.2

#### Subwoofer cardioid options

The X-Line Advance cardioid subwoofer configuration can be used to direct the output of an array of subwoofers to limit excessive amounts of bass in undesired areas. These arrays can be used to keep bass off of a stage, provide more consistent bass coverage in the audience, and reduces bass in the surrounding area.

Multiple subwoofers must be arrayed to create a cardioid polar pattern.

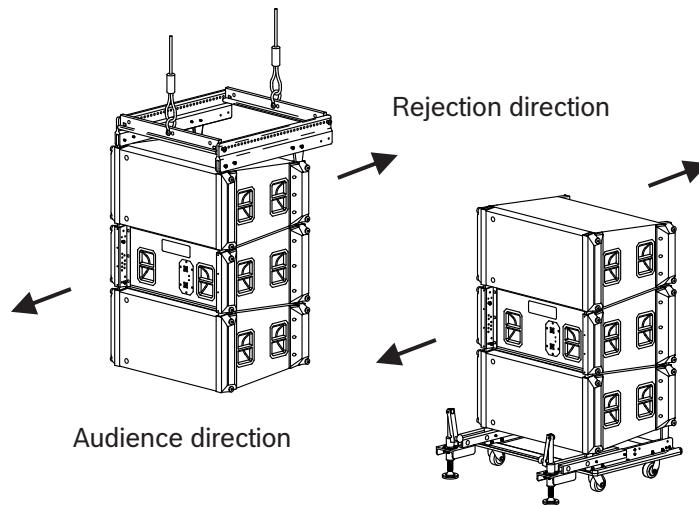


**Figure 8.5:** Cardioid pattern top view

The rejection may be less in smaller indoor environments than in larger outdoor environments due to room reflections. The subwoofers must be physically arrayed in one of the options shown.

#### X12-125F subwoofers

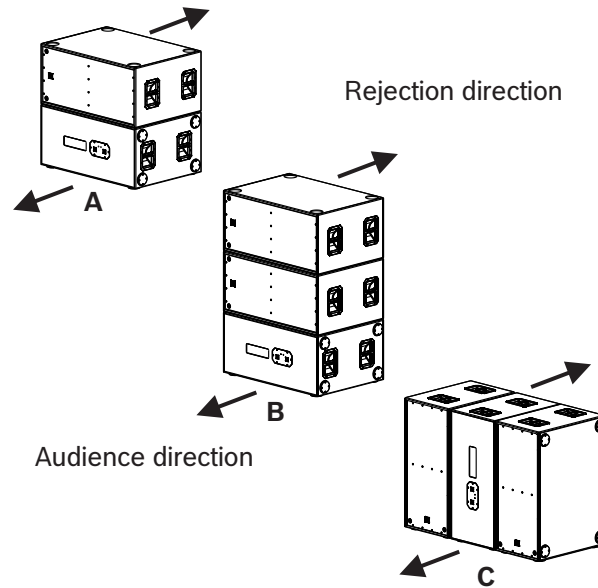
Assemble the cardioid subwoofer array with three X12-125F subwoofers orientated vertically. Direct the top and bottom subwoofers towards the audience and the middle subwoofer away from the audience (Rejection direction). The X12-125F subwoofer cardioid array can be ground stacked or suspended using the X12-125F-GRID. If desired, install the X12-125F-CGK cardioid grille kit on the middle element to improve the aesthetics of the array.



**Figure 8.6:** X12-125F cardioid options

### X12-128 subwoofers

Assemble the cardioid subwoofer array for X12-128 subwoofers with the following options:



**Figure 8.7:** X12-128 cardioid options

#### Cardioid option A:

Two X12-128 subwoofers orientated vertically. Direct the top subwoofer towards the audience and the bottom subwoofer away from the audience (Rejection direction).

#### Cardioid option B:

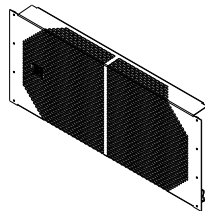
Three X12-128 subwoofers orientated vertically. Direct the top two subwoofers towards the audience and the bottom subwoofer away from the audience (Rejection direction).

#### Cardioid option C:

Three X12-128 subwoofers orientated horizontally. Direct the left and right subwoofers towards the audience and the center subwoofer away from the audience (Rejection direction).

## 8.2.3

### Installing the X12-125F-CGK Cardioid Grille Kit



**Figure 8.8:** X12-125F-CGK Cardioid Grille Kit



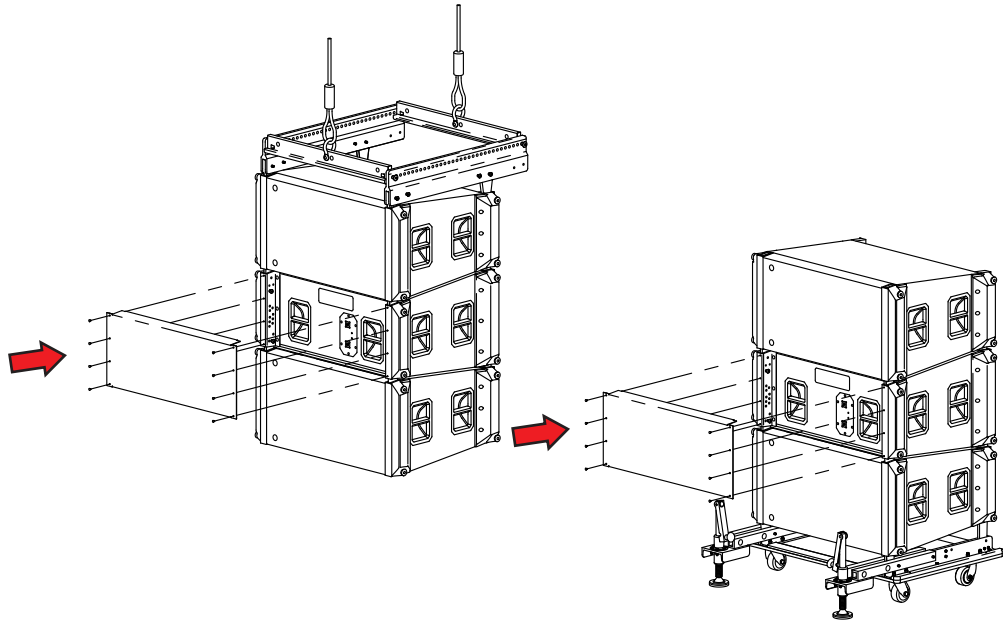
#### Notice!

Build the array prior to installing the X12-125F-CGK Cardioid Grille Kit.

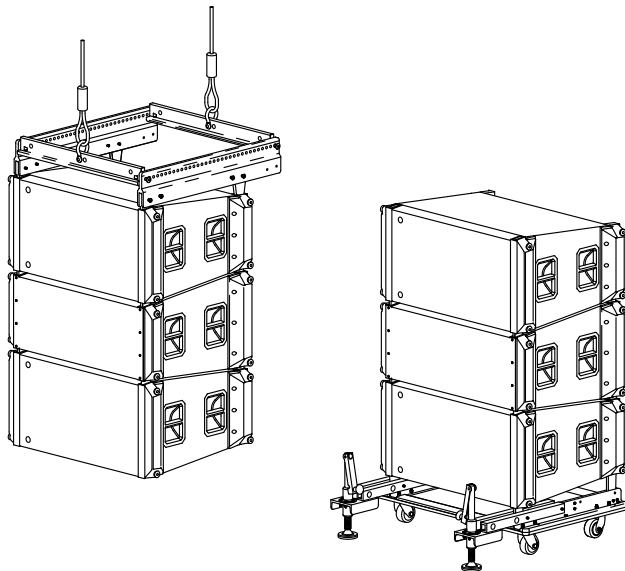
When the X12-125F-CGK is installed, the quick release pins for setting inter-cabinet angles are no longer accessible.

To install the X12-125F-CGK Cardioid Grille Kit, do the following:

1. Position the cardioid grille kit on the rear rigging extrusions. Ensure the screw holes are aligned top to bottom and side to side.



2. Insert the screws (provided) into the screw holes.
3. Tighten the screws. Ensure the Cardioid Grille Kit is attached securely to the rear of the X12-125F subwoofer.



#### Notice!

If desired, apply a drop of non-permanent thread locker to the screw threads to prevent loosening from vibration.

## 8.3

### Ground stacking a mixed array



#### Caution!

We recommend that two or more persons lift and place heavier loudspeakers. Single person lift and placement of heavier loudspeakers could cause injury.

**Notice!****Dolly wheel (the 4°) hole:**

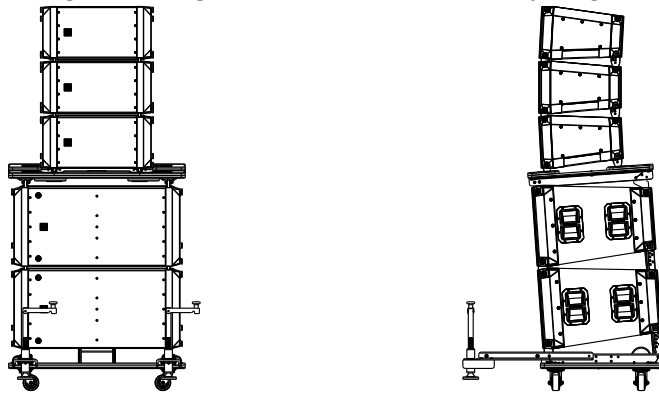
The bottom element to be landed on the dolly base must be pinned in the 4° hole (Ⓣ) in the ANGLE SELECT section. Compress the rear link bars until they contact the angle select pin and lock by adding a second pin in the EVEN holes of the ANGLE LOCK section.

Ensure the two front link bars are lowered and locked.

**Ground stack X1/X2 onto X12-125F in a mixed array**

To ground stack X1/X2 onto X12-125F in a mixed array, do the following:

1. Model your ground stack array in line array configuration software in order to determine configuration angles of the elements to build your ground stack array.



2. Remove the X12-125F-DOLLY top dolly cover.
3. Install the X12-125F-DAK dolly adapter kit.
4. If recommended by line array configuration software, install the X12-125F-DOK dolly outrigger kit. See *Assembling an X12-125F-DOK dolly outrigger kit to an X12-125F-DOLLY*, page 29.

Ensure the X12-125F-Dolly base is level, both front-to-back and side-to-side.

OR

If no outriggers are required, assemble the cardioid array on the dolly.

5. Set the configuration angle of the first subwoofer attached to the bottom dolly base.
6. If conventional subwoofer configuration is being used adjust the configuration angle on the second subwoofer.

OR

If cardioid subwoofer configuration is being used, see *Ground stacking subwoofers*, page 33.

7. Install the top dolly cover on the top subwoofer.
8. On the ground, set the configuration angle of the first X1/X2 element.
9. Place the first X1/X2 element onto the X12-125F DAK dolly adaptor kit.
10. Secure the X1/X2 element to the X12-125F-DAK dolly adapter kit using the attached ball detent pins.
11. Based on your mixed array configuration software report, set the angles on the remaining X1/X2 elements.
12. Stack the elements together to complete your ground stack mixed array.

**Refer to**

- *Assembling an X12-125F-DOK dolly outrigger kit to an X12-125F-DOLLY*, page 29
- *Ground stacking subwoofers*, page 33

## 9 Flying the system

### 9.1 Deciding which grid configuration to use

Choosing a grid is determined by the system down or up angles in combination with the number of elements in the array and the splay angle between them. To determine which grid model will achieve your desired angle or where the safety limitations are for the arrays, please use Electro-Voice line array configuration software to design your array, and observe all warnings and limitation messages displayed by the software.

#### 9.1.1 X12TC-GRID compact grid

The X12TC-GRID compact grids are appropriate for arrays where extreme up or down angles are not required. It is rated for a maximum hang of up to 24 X1 or X2 elements in a single column. Use Electro-Voice line array configuration software to determine if X12TC-GRID combined with the number of elements will achieve the acoustical coverage in the venue at a safe working load.



#### Notice!

X12TC-GRID comes with one spreader bar only. The use of a second spreader bar is not recommended with this grid.

X12TC-GRID includes one spreader bar and two sidearms. The spreader bar has four 0.84-inch (21.4 mm) holes through it for use as attachment points. The hole near the center of the bar labeled PICK HERE is used for lifting a single point hang. This hole is slightly off-center to compensate for the center of gravity of the respective X1 and X2 systems.

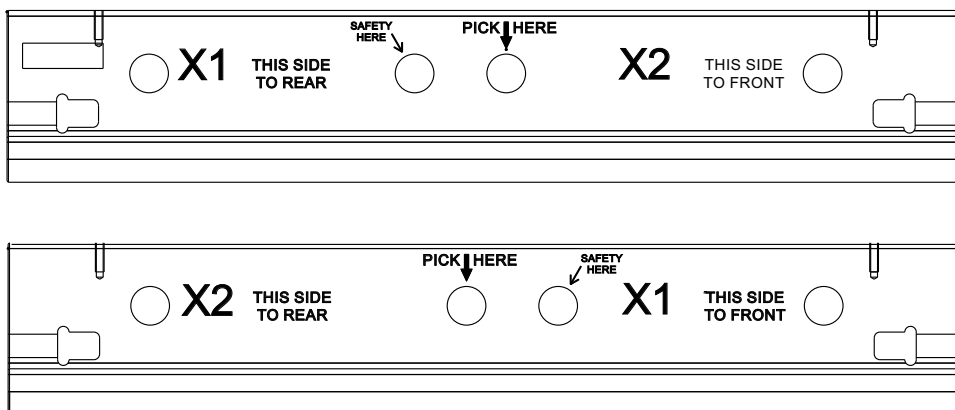
Pay close attention to which way the spreader bar is oriented with respect to the loudspeaker systems. Compare the wording on the left end of the spreader bar to the input panel label on the loudspeaker. For an X1 system, the bar should read X1 THIS SIDE TO REAR and for an X2 system it should read X2 THIS SIDE TO REAR.



#### Caution!

Verify the correct spreader bar orientation before lifting the array.

Failure to comply with this instruction results in the entire array tilting to one side at an unsafe angle.



**Figure 9.1:** X1/X2 spreader bar

The hole labeled SAFETY HERE is for attachment of a safety line if required by local regulations. If used, ensure there is minimal slack in the safety line but it is not so tight as to interfere with the vertical alignment of the array hanging from the pick point. The two outer holes may be used for lifting as a two-point lateral hang, often useful to prevent twisting of the



array. In this situation, lifting and suspension lines must not exceed 15° from vertical and both points must be lifted equally so the array is never more than ±5° from horizontal during the lift.



**Warning!**

Do not lift an array by attaching directly to the sidearms. Lift with the supplied spreader bar(s) only.

Failure to heed this warning may result in extensive property damage, serious injury or death.

The compact grid sidearms are usually attached with the excess overhang at the rear to allow for greater down-angle possibilities. For situations where more up-angle is possibly required, such as covering a high balcony in a theater, the grid can be reversed with the excess grid length overhanging the front of the array.

**Installing the X12TC-GRID to an X1 or X2 loudspeaker**

When the compact grid with its single spreader bar is used, the trim angle of the array is determined by the front-to-back attachment position of the spreader bar. This information is provided by the line array configuration software, a function of the array makeup and desired vertical aiming.



**Caution!**

Make sure that each end of each main grid spreader bar is pinned in the same number hole on both main grid side arms.

Make sure the pins attaching the ends of each spreader bar to a side arm are fully inserted and locked into the holes on both ends of each spreader bar.



**Notice!**

Using the PICK HERE hole alone requires a tie-off to stabilize the horizontal rotation of the array.

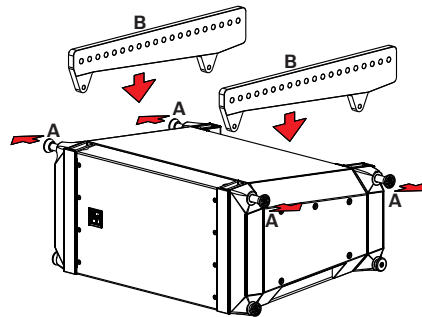


**Notice!**

Before flying the array, make sure that all captive twist lock pins are fully engaged in the rigging (no red showing between the pin knob and the element).

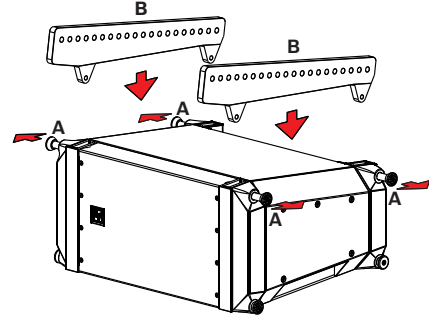
To install the X12TC-GRID, do the following:

1. Pull and twist two captive twist lock pins (A) on one side of the loudspeaker. Two captive twist lock pins are locked in the retracted (open) position.



Forward

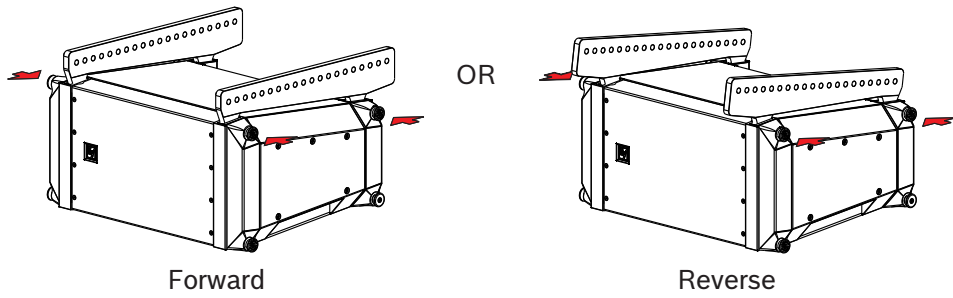
OR



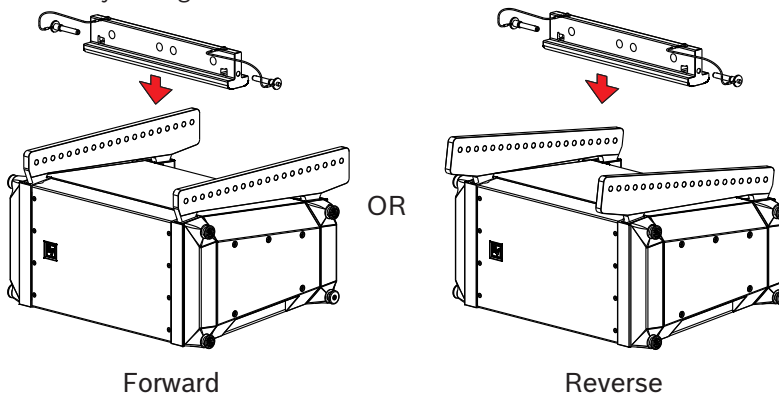
Reverse

2. Guide one sidearm (B) into the rigging bar channels until it is fully seated in the V-blocks.

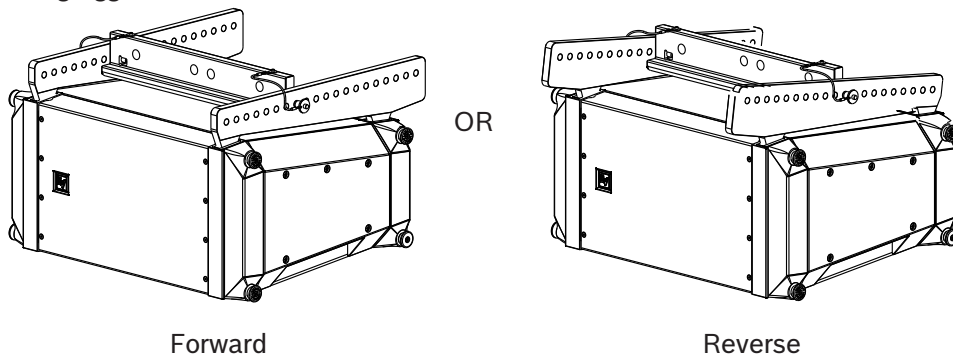
- Twist the two captive twist lock pins to engage.  
Two captive twist lock pins are unlocked in the engaged (closed) position.



- Repeat steps 1-3 on the opposite side of the loudspeaker.  
The loudspeaker now has two side arms attached.
- Attach one spreader bar to the two sidearms using the hole locations from Electro-Voice line array configuration software.

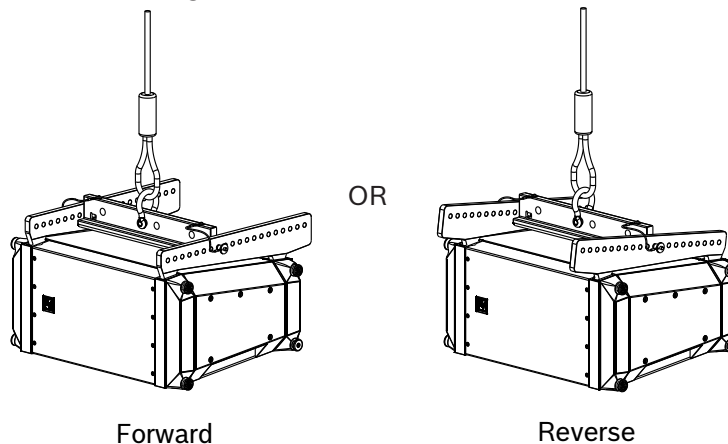


- Verify the spreader bar is correctly oriented for the model of loudspeaker (X1 or X2) being rigged.



- Attach a 5/8-inch shackle to the hole labeled PICK HERE on the spreader bar.  
Ensure the shackle is rated for overhead lifting.

8. Attach the lifting cable/chain to the shackle.



9. Verify all hooks, pins, shackles, and other associated rigging components are properly positioned and secure before lifting the array.

**Refer to**

- *Rigging structural strength ratings and safety factors* , page 69
- *Rigging inspection and precautions*, page 73

### 9.1.2

#### X12TE-GRID extended grid

X12TE-GRID extended grid is available for flying arrays that require greater up or down angles than are possible with the X12TC-GRID compact grid. The front and rear link bars of the X12TE-GRID are adjustable in three different positions to facilitate the extreme up-angles sometimes required in venues with multiple high balconies. The additional length of the X12TE-GRID also enables more extreme down-angles from a single point than would otherwise be possible. Note that the maximum load must be derated as the angle becomes more extreme. Consult line array configuration software for limitations in a particular array configuration. The X12TE-GRID is also required in order to use the X12PU-BGK pull-up grid to aim an array using the rear compression rigging method. The X12TE-GRID comes with two spreader bars to allow the use of two motors to provide easy angle control of large arrays, especially when compression rigging is used. The resulting fore-and-aft pick points also provide better horizontal stability than a typical rear tie-off point.

Each spreader bar has four 0.84-inch (21.4 mm) holes through it for use as attachment points. The hole near the center of the bar labeled PICK HERE is used for lifting a single point hang. This hole is slightly off-center to compensate for the center of gravity of the respective X1 and X2 systems.

Pay close attention to which way each spreader bar is oriented with respect to the loudspeaker systems. Compare the wording on the left end of the spreader bar to the input panel label on the loudspeaker. For an X1 system, the bar should read X1 THIS SIDE TO REAR and for an X2 system it should read X2 THIS SIDE TO REAR. When using two spreader bars, lift from the PICK HERE points of each bar and assure both bars are correctly oriented for the systems being lifted.



**Warning!**

Do not lift an array by attaching directly to the sidearms. Lift with the supplied spreader bar(s) only.

Failure to heed this warning may result in extensive property damage, serious injury or death.

### Installing the X12TE-GRID to an X1 or X2 loudspeaker or the X12-125F-GRID to an X12-125F subwoofer



#### Caution!

The extended grid sidearms are heavy and likely to tip if not secured, potentially causing damage and/or personal injury if one should fall.

Always maintain a good grip on the sidearm until both twist-lock pins are fully engaged.



#### Caution!

Make sure that each end of each main grid spreader bar is pinned in the same number hole on both main grid side arms.

Make sure the pins attaching the ends of each spreader bar to a side arm are fully inserted and locked into the holes on both ends of each spreader bar.



#### Notice!

Before flying the array, make sure that all captive twist lock pins are fully engaged in the rigging (no red showing between the pin knob and the element).



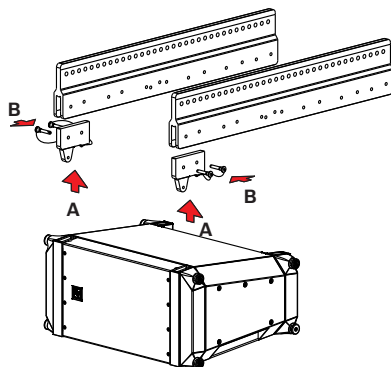
#### Notice!

In this section, the rigging steps illustrated with X1/X2 full-range drawings are performed the same way for the X12-125F subwoofer. Rigging differences between the X1/X2 full-range elements and the X12-125F subwoofer are noted in the steps, when applicable.

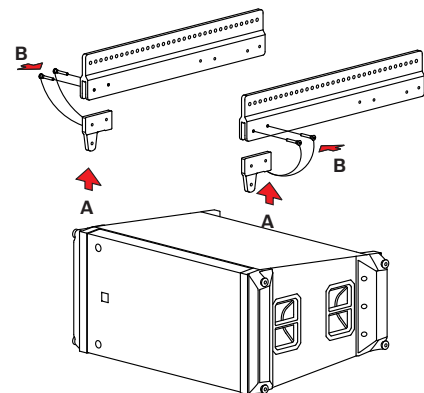
To install the X12TE-GRID or X12-125F-GRID, do the following:

1. Attach front link bars (A) to the side arms.

Consult the line array configuration software for the A, B, or C position of the front link bars for the particular array being flown with X1 or X2 elements. Only one position is available for the link bars on the X12-125F-GRID. If additional up angle is required when using the X12-125F-GRID reverse the side arms.

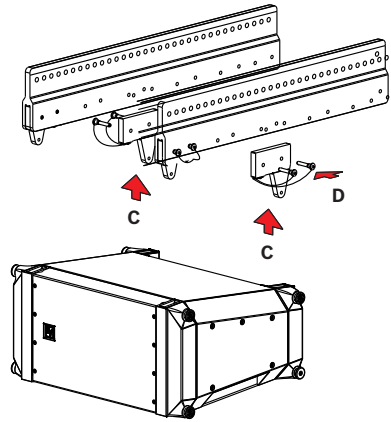


X12TE-GRID

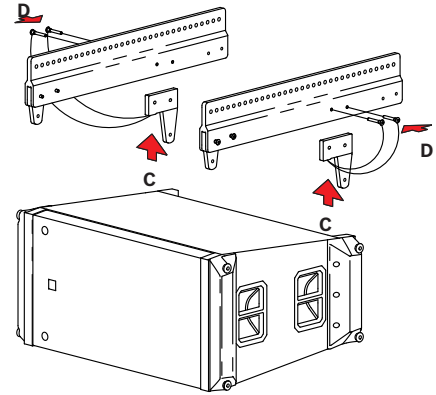


X12-125F-GRID

2. Insert the attached quick-release pins (B).  
Verify all quick-release pins are inserted completely through the sidearm and securely locked in position.
3. Attach rear link bars (C) to the side arms.

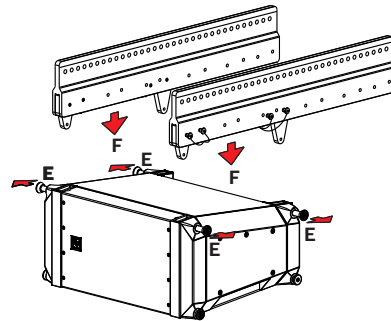


X12TE-GRID

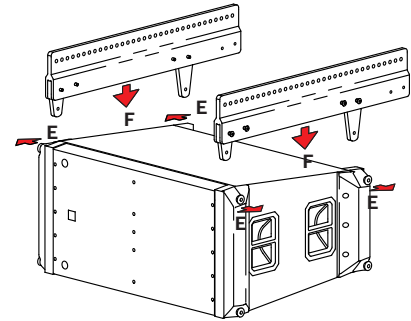


X12-125F-GRID

4. Insert the attached quick-release pins (D).  
Verify all quick-release pins are inserted completely through the sidearm and securely locked in position.
5. Pull and twist two captive twist lock pins (E) on one side of the enclosure.  
Two captive twist lock pins are locked in the retracted (open) position.

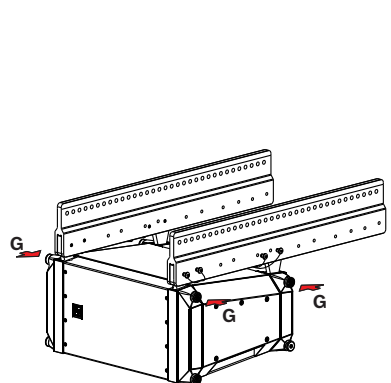


X12TE-GRID

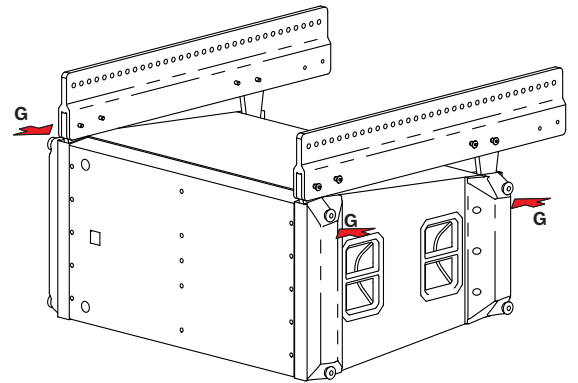


X12-125F-GRID

6. Guide one assembled sidearm (F) into the rigging bar channels until it is fully seated in the V-blocks.  
Keep a good grip on the sidearm until both pins are completely engaged through the rigging.
7. Twist the two captive twist lock pins (G) to engage.  
Two captive twist lock pins are unlocked in the engaged (closed) position.



X12TE-GRID

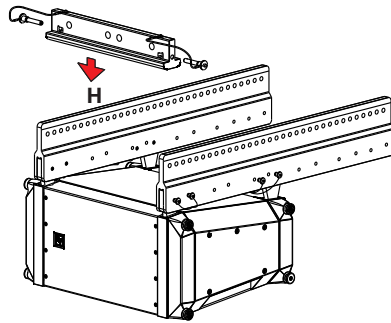


X12-125F-GRID

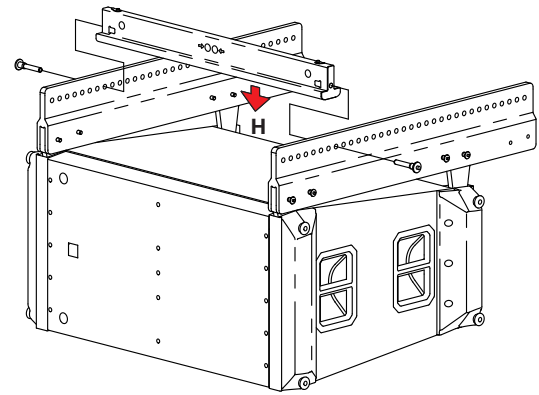
8. Repeat steps 6-7 on the opposite side of the enclosure.  
The second assembled sidearm is attached to the element.
9. Verify the spreader bar is correctly oriented for the model of loudspeaker (X1, X2 elements or X12-125F subwoofer) being rigged.

Spreader bars for X1 or X2 elements must face the same way with their pick point holes aligned.

- Attach a single spreader bar (H) to the two sidearms at the hole position determined by the line array configuration software.

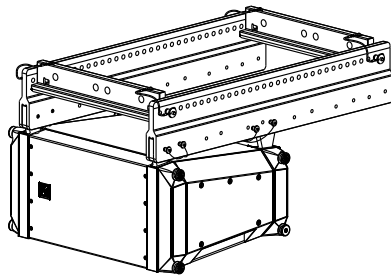


X12TE-GRID

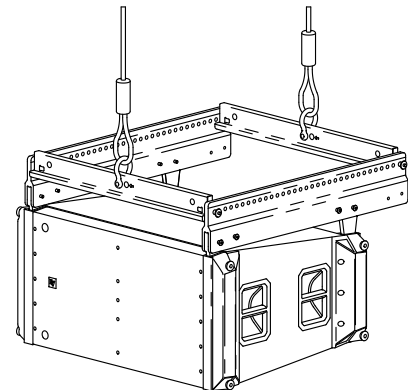


X12-125F-GRID

- If using two motors and two spreader bars, attach one spreader bar at hole #1 and one spreader bar at hole #33.



X12TE-GRID



X12-125F-GRID

- Attach a 5/8-inch shackle to the hole labeled PICK HERE on the spreader bar(s). Make sure the shackle is rated for overhead lifting.
- Attach the lifting cable/chain(s) to the shackle(s).
- Verify all hooks, pins, shackles, and other associated rigging components are properly positioned and secure before lifting the array.

### X1 or X2 extended grid rigging configurations



#### Warning!

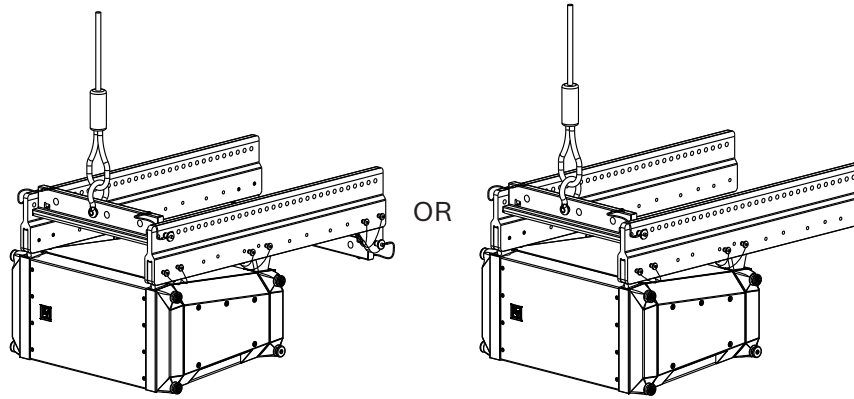
Do not lift an array by attaching directly to the sidearms. Lift with the supplied spreader bar(s) only.

Failure to heed this warning may result in extensive property damage, serious injury or death.



#### Notice!

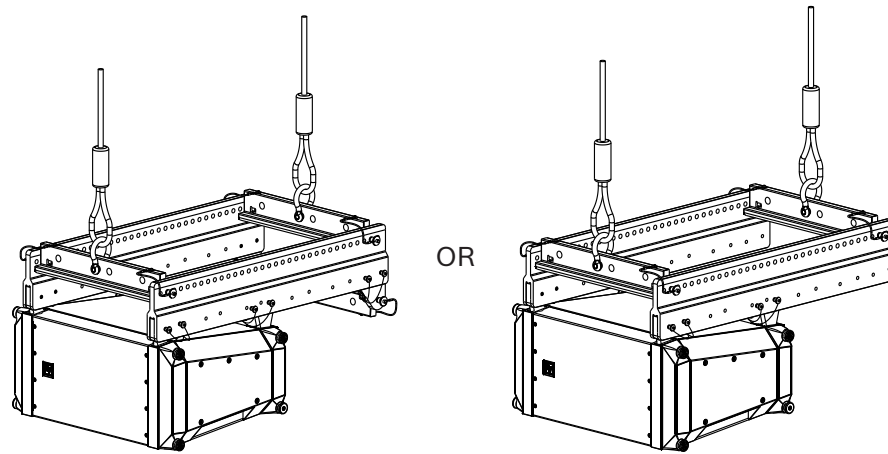
In this section, the rigging steps illustrated with X1/X2 full-range drawings are performed the same way for the X12-125F subwoofer. Rigging differences between the X1/X2 full-range elements and the X12-125F subwoofer are noted in the steps, when applicable.



With pull-up bar

Without pull-up bar

Figure 9.2: X12TE-GRID - Single



With pull-up bar

Without pull-up bar

Figure 9.3: X12TE-GRID - Dual

**Refer to**

- *X12-125F-GRID grid, page 53*
- *Rigging structural strength ratings and safety factors , page 69*
- *Rigging inspection and precautions, page 73*

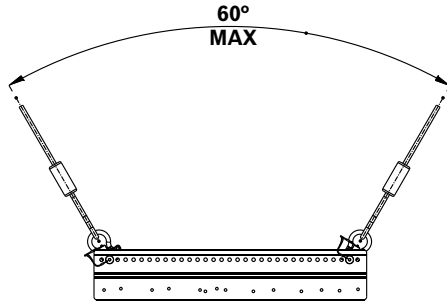
**9.1.3**

**X12PU-BGK or X12-125FPU-BGK pull-up kits**

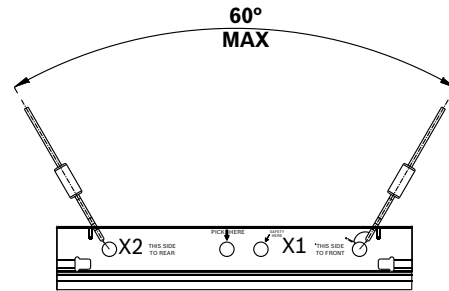
X12PU-BGK and X12-125FPU-BGK pull-up kits are used when the compression rigging method is being used with an array or when extreme down angles beyond the capabilities of the extended grid are required. This is a way to achieve extreme down angles, such as might be encountered in a distributed arena system. When using one X12TE-GRID and one X12PU-BGK or one X12-125F-GRID and one X12-125FPU-BGK in this fashion, the angle between the suspension lines must never be allowed to exceed 30°. For maximum angles, restrictions and limitations, consult the line array configuration software and follow all limitations and restrictions recommended by the software. The instructions in this section refer specifically to the X12PU-BGK pull-up kit for X1 and X2 loudspeakers, the same procedure applies to the X12-125FPU-BGK for X12-125F subwoofers, except where noted.

**Warning!**

When using two pick points to hang the array with either the X12TE-GRID, X12-125F-GRID or an individual spreader bar, the maximum allowable angle to the rigging points is 60°. By exceeding the maximum allowable angle, the rigging system may fail, resulting in extensive property damage, severe injury or death.



X12TE-GRID



Spreader bar

**Using X12PU-BGK or X12-125FPU-BGK pull up grid for compression rigging method**

For rear-rigging compression, the user must build a pull-up assembly. The bottom grid kit includes two spreader bars and two pull-up link bars. One spreader bar attaches to the rear of the bottom grid. The other spreader bar and the two pull-up link bars attach to the bottom of the top grid at the rear-most attachment position. The remaining components of the pull-up assembly must be provided by the user.

Use a lever hoist as the actual pull-up device to compress the array. The user extends the chain from the hoist and attaches it to the pull-up spreader bar on the top grid using a 5/8-inch shackle. Under the hoist, a load cell is attached to measure the compression force on the array. One end of a 2-foot-long (or 0.6-meter-long) wire rope sling attaches to the bottom hook of the load cell. The other end of the wire rope sling attaches to the spreader bar on the bottom grid using a 5/8-inch shackle. Using longer or shorter wire ropes than the recommended length may cause small errors between the predicted angle in the software and the actual array angle.

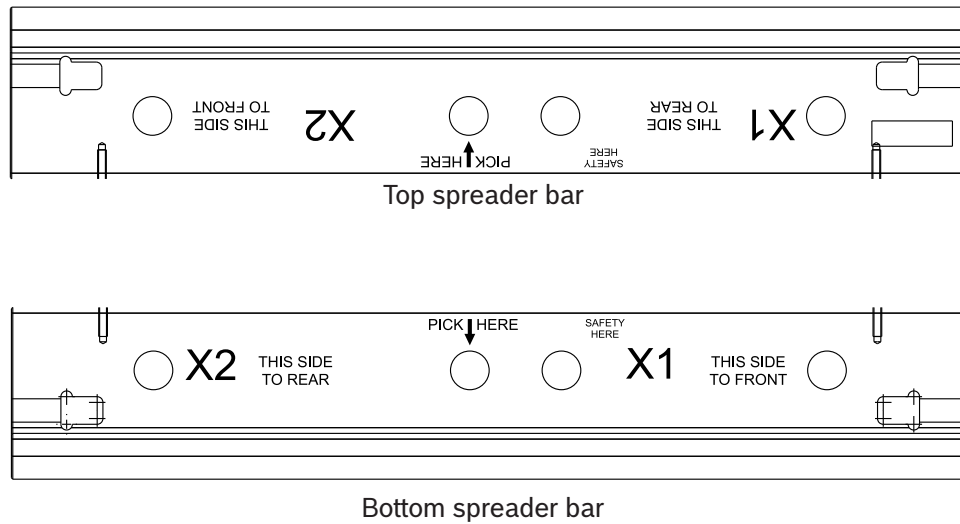
The user provides the 5/8-inch shackles, wire rope sling, lever hoist, and load cell. Electro-Voice recommends using a wire rope sling with a load rating of at least 2400 pounds (or 1100 kg) in vertical lifting configuration. Electro-Voice recommends using a Columbus-McKinnon model 653 lever hoist having a 1.5-ton rating and 20 feet of chain. Electro-Voice line-array configuration software assumes that this lever hoist is used when the pull-up option is selected. If a different pull-up hoist is used, the angle at which an array hangs may be different from what the line array configuration software predicts. The use of a load cell is required to prevent excessive force on the array. The load cell should be from a brand commonly used in the entertainment industry, such as (but not limited to) Motion Labs, Dillon, Straightpoint, Ron Stagemaster, or BroadWeigh.

**Caution!**

Proper spreader bar orientation must be maintained when used in conjunction with the pull-up grid. Always orient bars to the system model when viewed right-side-up, and then simply rotate the top pull-up spreader bar upside-down before attaching to the pull-up bars at the rear of an X12TE-GRID. Do not swap ends!

Correct orientation puts the pick holes of all spreader bars in alignment in the same vertical plane. The spreader bar at the bottom of an array will always be oriented right-side-up.



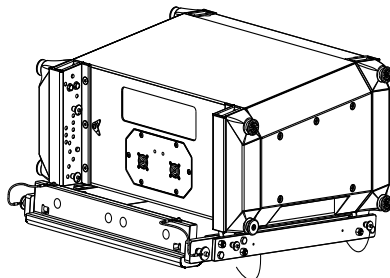


**Figure 9.4:** X1/X2 spreader bars properly orientated for use with pull-up grid for X2 array.

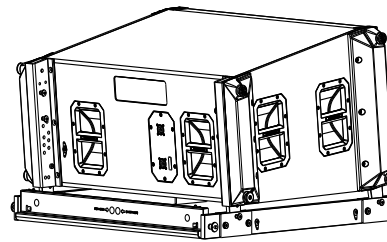


**Notice!**

Spreader bars for the X12-125F subwoofers are symmetrical and can be used in either direction.



X12PU-BGK



X12-125FPU-BGK

**Figure 9.5:** X12PU-BGK and X12-125FPU-BGK installed

**Using the bottom grid with a top grid for compressing an X1 or X2 array**

The bottom grid assembly is installed on the bottom-most element in the array.



**Caution!**

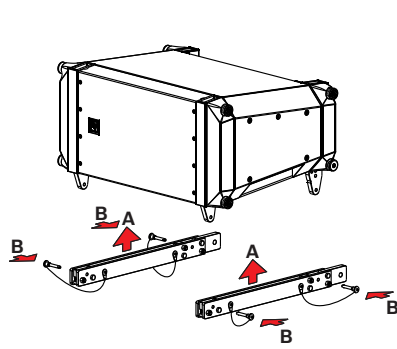
Make sure that each end of each main grid spreader bar is pinned in the same number hole on both main grid side arms.

Make sure the pins attaching the ends of each spreader bar to a side arm are fully inserted and locked into the holes on both ends of each spreader bar.

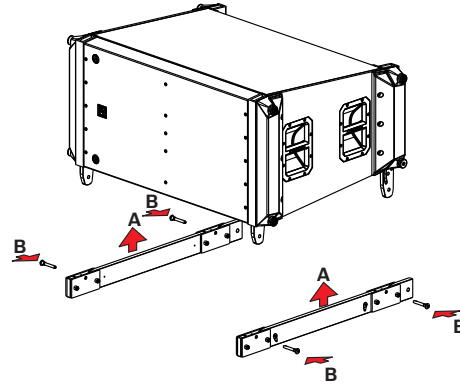
To install the bottom grid and top grid, do the following:

1. Extend and lock the lower front link bars.
2. Extend and lock the rear link bars in the 10° position.
3. With the side arm V-blocks facing up and the solid bar extension facing the rear, guide the V-blocks of the bottom grid side arms (A) onto the extended link bars of the loudspeaker.

Do not release the side arm until it is securely attached to the loudspeaker.

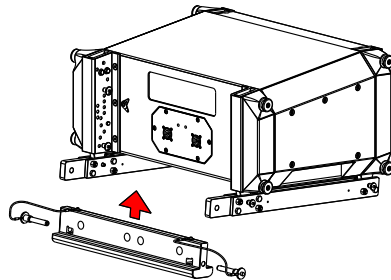


X12PU-BGK

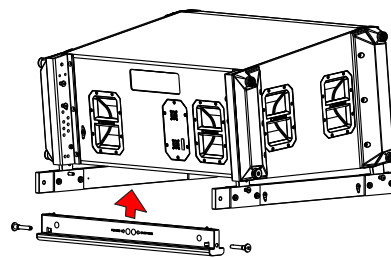


X12-125FPU-BGK

4. Insert the attached quick-release pins (B) through each side arm and link bars, front and rear.  
Make sure all quick-release pins are completely through the side arms and securely locked.
5. Attach a spreader bar to the rear of the two side arms.

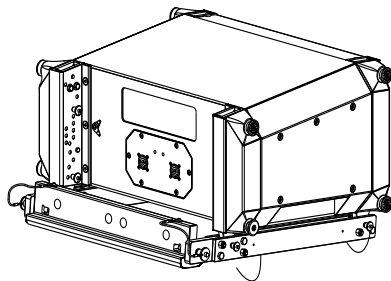


X12PU-BGK

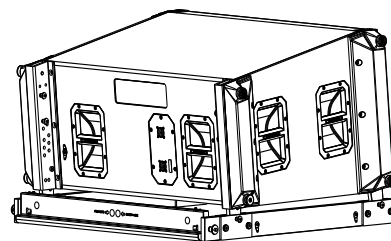


X12-125FPU-BGK

6. The bottom grid is now assembled.

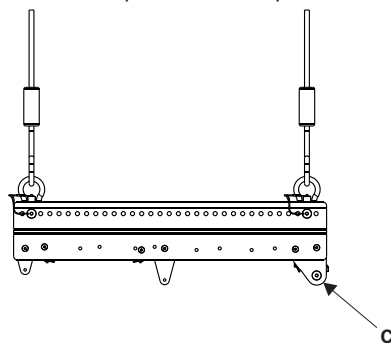


X12PU-BGK

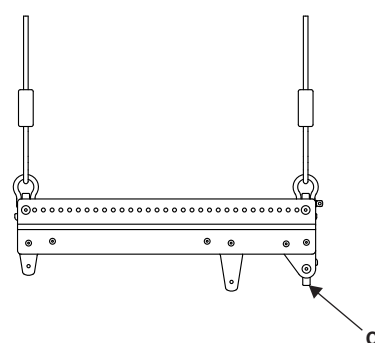


X12-125FPU-BGK

7. Attach the two pull-up link bars to the rear of the top grid side arms (C) using the attached quick-release pins.



X12TE-GRID

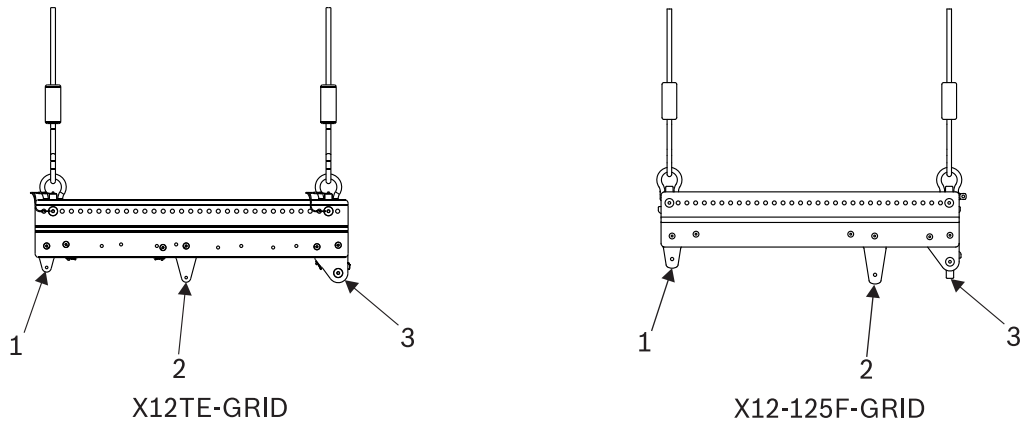


X12-125F-GRID

8. Assemble the second spreader bar of the bottom grid kit to the pull-up link bars installed at the rear of the top grid.  
 This spreader bar must be installed upside-down, as described previously. Make sure all quick-release pins are inserted completely through the side arm and securely locked in position.

**Compression method aiming using a pull-up to the grid**

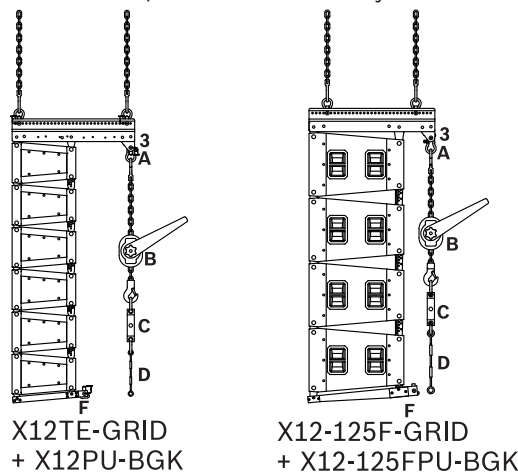
Using a X12TE-GRID and an X12PU-BGK to compress an X1 or X2 array or an X12-125F-GRID and X12-125FPU-BGK to compress an X12-125F subwoofer array.



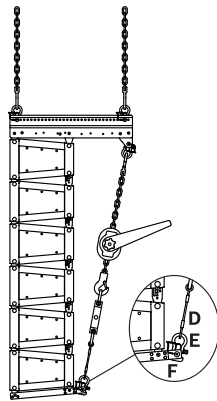
1	Front link bar
2	Rear link bar
3	Pull-up link bar and spreader bar

To pull-up to the X12TE-GRID or X12-125F-GRID, do the following:

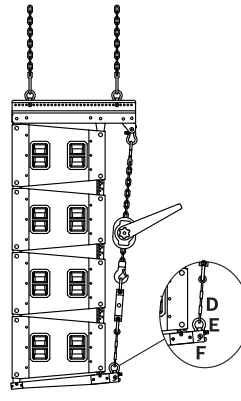
1. Using a 5/8-inch shackle rated for overhead lifting (A), attach the lever hoist (B) to the spreader bar on the top grid (3).
2. Attach the load cell (C) to the bottom of the lever hoist (B).  
 Additional 5/8-inch shackles may be needed depending on the type of load cell used.
3. Attach the wire rope (D) to the bottom of the load cell (C).  
 Additional 5/8-inch shackles may be needed depending on the type of load cell used.



- Using a 5/8-inch shackle rated for overhead lifting (E), attach the wire rope (D) to the appropriate pick point on the spreader bar located on the bottom grid (F).



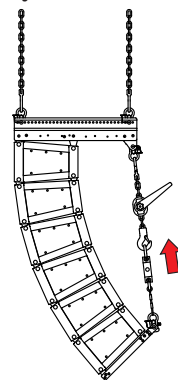
X12TE-GRID  
+ X12PU-BGK



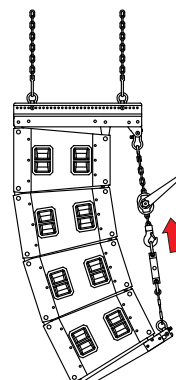
X12-125F-GRID  
+ X12-125FPU-BGK

- Attach a chain bag to the pull-up hoist and insert the unextended chain into the chain bag.
- Make sure all hooks, pins, shackles, and other associated rigging components are properly positioned and secure before lifting the array.
- Lift with the pull-up hoist to raise the bottom element to compress the rear rigging of all the elements in the array.

As each element of the array moves into position from the bottom, the load cell tension value will increase and the lever hoist will require more effort. As the final element lifts into place, the gap between the top box and the second box will close, the lever hoist resistance will increase, and the value observed on the load cell will increase above the minimum value given by the software. This indicates that the array is fully compressed. Carefully observe the value on the load cell and do not exceed the maximum value given by the software.



X12TE-GRID  
+ X12PU-BGK



X12-125F-GRID  
+ X12-125FPU-BGK



### Warning!

Line array configuration software from Electro-Voice will report the maximum force that can be used to compress the rear rigging of all the elements.

The use of a load cell is required. Applying excess force can cause damage to the rigging.

- Lift the array to the desired height.
- Adjust the front and rear top grid hoists to the tilt angle recommended by Electro-Voice line array configuration software.

### 9.1.4

#### X12-125F-GRID grid

The X12-125F-GRID grid is appropriate for arrays where extreme up or down angles are not required. It is rated for a maximum hang of up to 18 X12-125F subwoofers in a single column. Use the line array configuration software to determine the number of subwoofers needed to achieve the desired acoustical coverage in the venue at a safe working load.

X12-125F-GRID grid includes two spreader bars and two side arms. Each spreader bar has four 0.84-inch (21.4 mm) holes through it for use as attachment points. The center hole on the bar labeled PICK HERE is used for suspending up to nine X12-125F systems using a single point hang. This hole is on center of the spreader bar and on the center of gravity of the X12-125F subwoofer. For suspending more than nine X12-125F systems, the user must use a bridle from the two holes at the ends of the spreader bar.

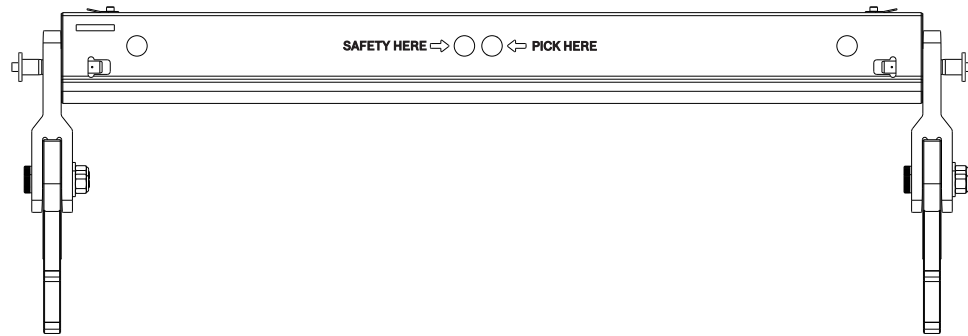


Figure 9.6: X12-125F-GRID spreader bar

The hole labeled SAFETY HERE is for attachment of a safety line if required by local regulations. If used, ensure there is minimal slack in the safety line but it is not so tight as to interfere with the vertical alignment of the array hanging from the pick point. The two outer holes may be used for lifting as a two-point lateral hang, often useful to prevent twisting of the array. In this situation, lifting and suspension lines must not exceed 15° from vertical and both points must be lifted equally so the array is never more than ±5° from horizontal during the lift.

#### Warning!

The spreader bar holes labeled PICK HERE and SAFETY HERE are not valid for any X12-125F subwoofer array exceeding nine elements, even if two spreader bars are used. For arrays in excess of nine elements, the two outer-most holes of the spreader bar must be used in a bridled end pick configuration, regardless of whether one or two bars are being used. Failure to heed this warning may result in extensive property damage, serious injury or death. Consult the line array configuration software and follow all warnings, limitations, and restrictions recommended by the software.



#### Warning!

Do not lift an array by attaching directly to the sidearms. Lift with the supplied spreader bar(s) only. Failure to heed this warning may result in extensive property damage, serious injury or death.



The X12-125F grid side arms are usually attached with the excess overhang at the rear to allow for greater down-angle possibilities. For situations where more up-angle is possibly required, such as covering a high balcony in a theater, the grid can be reversed with the excess grid length overhanging the front of the array.

### Installing the X12-125F-GRID to a X12-125F subwoofer

When the X12-125F-GRID grid with a single spreader bar is used, the trim angle of the array is determined by the front-to-back attachment position of the spreader bar. This information is provided by the line array configuration software, a function of the array makeup and desired vertical aiming.



#### Caution!

Make sure that each end of each main grid spreader bar is pinned in the same number hole on both main grid side arms.

Make sure the pins attaching the ends of each spreader bar to a side arm are fully inserted and locked into the holes on both ends of each spreader bar.



#### Notice!

Using the PICK HERE hole alone requires a tie-off to stabilize the horizontal rotation of the array.



#### Notice!

Before flying the array, make sure that all captive twist lock pins are fully engaged in the rigging (no red showing between the pin knob and the element).

Assemble the X12-125F-GRID the same way as for the X12TE-GRID. All other main grid and pull-up grid assembly procedures are identical for X1, X2, and X12-125F subwoofers.

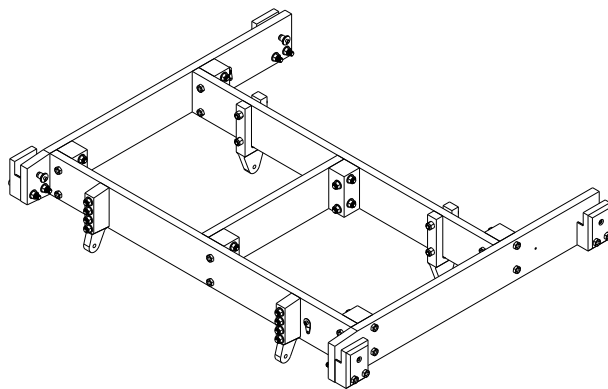
#### Refer to

- *Installing the X12TE-GRID to an X1 or X2 loudspeaker or the X12-125F-GRID to an X12-125F subwoofer, page 44*
- *X12PU-BGK or X12-125FPU-BGK pull-up kits, page 47*
- *Rigging structural strength ratings and safety factors, page 69*
- *Rigging inspection and precautions, page 73*

## 9.1.5

### X12-125F-AG adapter grid for X1/X2 to X12-125F flying subwoofer

The X12-125F-AG adaptor grid safely suspends up to nine X1 or X2 full-range loudspeakers below X12-125F subwoofers in a single flown mixed array.



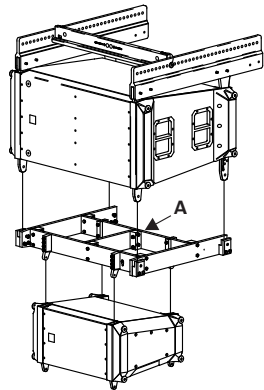
**Figure 9.7:** X12-125F-AG adapter grid

#### Installing the X12-125F-AG adapter grid

Suspend the X12-125F subwoofer first in accordance with aiming instructions given in the line array configuration software.

To install the X12-125F-AG adapter grid, do the following:

1. Set all inter-box angles as instructed in the line array configuration software.
2. Retract and lock the four upper twist-lock pins on the topmost X1/X2 element in the array.
3. Place the X12-125F-AG adapter grid (A) on top of the topmost X1/X2 element so the four link bars protruding from the bottom of the adapter grid are fully seated in the rigging V-blocks on the X1/X2.



4. Release the four twist-lock pins on the X1/X2 element to engage. Verify all four twist-lock pins are fully seated (No red showing between the pull knob and the enclosure).
5. Disengage the four quick-release pins on the large V-block pockets at the four outer corners of the adapter grid.
6. Lower the subwoofer onto the mounted adapter grid so the link bars of the bottom subwoofer are fully seated in the four large V-block pockets.
7. Replace the four quick-release pins in the large V-block pockets. Thereby linking the subwoofer link bars to the adapter grid. Verify all four twist-lock pins are fully seated (No red showing between the pull knob and the enclosure).
8. Raise the assembly to continue to add the remaining X1/X2 elements.
9. Repeat steps 1-8, until the desired number of elements are added to the array according to the line array configuration software instructions.



#### Notice!

Before flying the array, make sure that all captive twist lock pins are fully engaged in the rigging (no red showing between the pin knob and the element).

## 9.2

### Assembling and flying an array

Use Electro-Voice line array configuration software to design the array.

#### 9.2.1

#### Lifting and flying arrays directly from a dolly

Arrays can be flown from the X12T-DOLLY or X12-125F-DOLLY dollies and the angles set on the elements once the array is clear of the dolly and still within reach.



#### Caution!

When suspending any Electro-Voice loudspeaker array overhead, the working-load limit must never be exceeded for the individual enclosure rigging point, for the overall enclosure, or for any of the rigging accessories.

**Warning!**

Do not lift an array by attaching directly to the sidearms. Lift with the supplied spreader bar(s) only.

Failure to heed this warning may result in extensive property damage, serious injury or death.

**Warning!**

The spreader bar holes labeled PICK HERE and SAFETY HERE are not valid for any X12-125F subwoofer array exceeding nine elements, even if two spreader bars are used. For arrays in excess of nine elements, the two outer-most holes of the spreader bar must be used in a bridled end pick configuration, regardless of whether one or two bars are being used.

Failure to heed this warning may result in extensive property damage, serious injury or death.

Consult the line array configuration software and follow all warnings, limitations, and restrictions recommended by the software.

**Caution!**

When lifting a column of enclosures, make sure the correct dolly pins are released from the dolly base. There are four dolly pins for each stack on the dolly base. (A total of eight pins on the X12T-DOLLY base.)

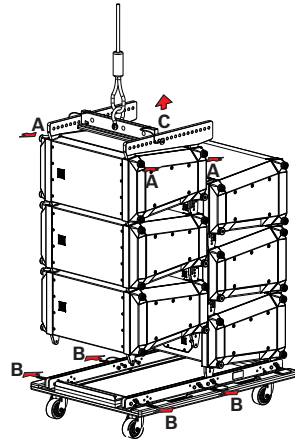
If the column of enclosures is lifted with any of the dolly pins still locking the speakers to the base, the dolly base will lift and tip. Property damage and personal injuries may occur.

To lift and fly an array directly from a dolly, do the following:

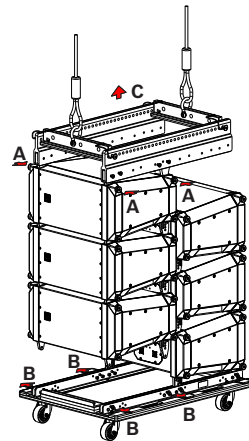
1. If using the X12TC-GRID for X1 or X2, choose the forward or reversed orientation.  
OR  
If using the X12TE-GRID for X1 or X2, preassemble each sidearm with front and rear link bars in the appropriate A, B, or C position.  
OR  
If using the X12-125F-GRID to fly X12-125F subwoofers, select forward or reverse orientation and pre-assemble each sidearm with front and rear link bars in the appropriate locations.
2. Pull and twist the four captive twist lock pins on the top element of the stack to be lifted. Four captive twist lock pins are locked in the retracted (open) position.
3. Place one grid sidearm into the rigging bar channels of the first stack to be lifted and engage both V-blocks on that side.
4. Twist the two captive twist lock pins (A) to engage.



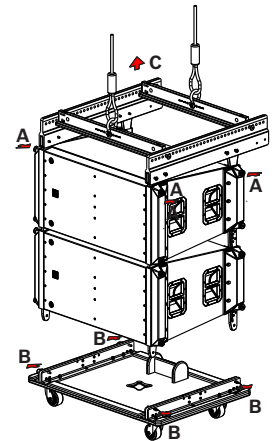
Make sure the pins are engaged in the closed position. Illustration shows the X12TC-GRID (left), the X12TE-GRID (center), and the X12-125F-GRID (right).



X12TC-GRID &  
X12T-DOLLY



X12TE-GRID &  
X12T-DOLLY



X12-125F-GRID &  
X12-125F-DOLLY

5. Repeat steps 2-4 on the opposite side.  
The grid should now be attached to the column of enclosures.
6. Install one spreader bar between the side arms in the appropriate hole as determined by the line array configuration software.  
OR  
If using two spreader bars, install one spreader bar at hole #1 and install one spreader bar at hole #33.
7. Attach a 5/8-inch shackle(s) to the pick point on the spreader bar(s).  
Make sure the shackle is rated for overhead lifting.
8. Attach the hoist chain hook to the shackle.
9. Disengage all four dolly pins (B) from the bottom rigging on the column to be lifted.
10. Make sure all hooks, pins, shackles, and other associated rigging components are properly positioned and secure before lifting the array.
11. Lift column of enclosures (C).
12. Turn the X12T-DOLLY around.
13. Roll the dolly out from under the lifted column.
14. Set the inter-box splay angles according to line array configuration software instructions.  
If choosing to aim by the compression method, install the upper portion of the pull-up grid kit at this time.
15. Pull and twist the four captive twist lock pins on the top element of the next column of enclosures to add to the array.
16. Land the flown column on top of the next column.
17. Twist the four captive twist lock pins to engage.  
Make sure all pins are engaged in the closed position.
18. Repeat steps 9-17 until the array is complete.

### Adjusting the splay angles

Use the report from the line array configuration software to set the angles to build the array. The angle between elements is set on the element above. If using compression, the unused quick-release pins should be placed in the PIN PARK holes. If using a two-pin fixed hang, lift the bottom rear of each successive element starting from the bottom until it hits the stop at the selected angle.

**Notice!**

Use of a separate cable pick to support the weight of cabling is recommended, especially on very tall arrays.  
Cable weight can change the aiming angle of an array.

**Refer to**

- *Setting rear link angles, page 15*
- *Stacking X1, X2, and X12-125F elements onto a dolly, page 21*

**9.2.2****X12TC-GRID with pull-back to venue**

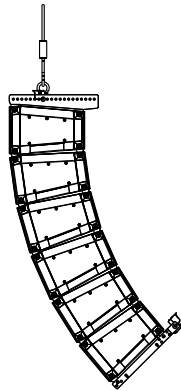
Using an X12TC-GRID combined with the X12PU-BGK an array can be pulled back to the venue.

**Notice!**

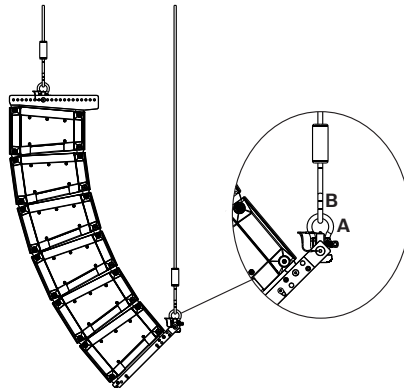
Only the double pin method is allowed when pull back to the venue is planned. Do not use single pin compression method in this instance.

To pull-back to the venue, do the following:

1. Attach the X12PU-BGK bottom section with spreader bar to the bottom element.

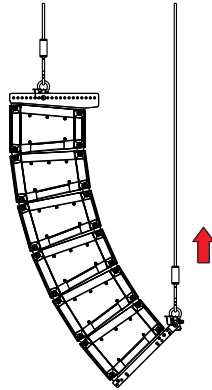


2. Attach a 5/8-inch shackle (A) to the pick point on the spreader bar. Ensure the shackle is rated for overhead lifting.



3. Attach the pull-back hoist chain hook (B) to the shackle.
4. Verify all hooks, pins, shackles, and other associated rigging components are properly positioned and secure before lifting the array.

5. Lift the array to the desired height.



6. Adjust the top grid hoist and bottom pull-back hoist to tilt the array to the angle recommended by Electro-Voice line array configuration software.

**Refer to**

- *X12TC-GRID compact grid, page 40*
- *Lifting and flying arrays directly from a dolly, page 55*

### 9.2.3

#### Storing empty dollies

When storing empty dollies, up to five dollies can be stored in the floor space of one.



**Notice!**

When storing multiple dollies of X12T-DOLLY, X12-125F-DOLLY and X12-128-DOLLY they may be stacked on top of each other. When stacking mixed dolly models in a single stack it is recommended to place all of the X12-125F-DOLLY dollies on the bottom. The X12T-DOLLY, and X12-128-DOLLY may be stacked in any order. Use ratchet straps to tie the entire stack of transport dollies together.

Unsecured dollies may roll off each other if the bottom dolly stops abruptly on an obstruction like the bottom of a ramp.

**X12T-DOLLY:**

To store an X12T-DOLLY, do the following:

1. Pull the four ball detent pins from the four corners of the dolly base.
2. Place the two dolly side panels on top of each other with their carpeted sides together on the dolly base between the transport rails.
3. Pick up the top cover with link bars pointing down and set it squarely onto the dolly base so as to nest the four link bars into the V-blocks on each corner.
4. Insert an attached dolly detent pin into each corner V-block to lock the two parts together.

Ensure the ball detent pin goes through the rigging bar and the other side of the transport rail.

**X12-128-DOLLY:**

To store a single X12-128-DOLLY, do the following:

1. Place the top dolly cover into the dolly base with the wheel pockets are facing up.
2. Secure with a ratchet strap.

Ensure there is enough clearance between the wheels that the ratchet mechanism does not interfere with stacking.

**X12-125F-DOLLY:**

To store an X12-125F-DOLLY, do the following:

1. Pin the dolly top rear link bars in the retracted (storage) position.
2. Pull the ball detent pins at the four corners of the dolly base.
3. Align the front of the dolly top (short, non-retractable bars) with the front of the dolly base.
4. Pick up the dolly top cover with link bars pointing down and set it squarely onto the dolly base so as to nest the four link bars into the V-blocks on each corner.
5. Insert an attached dolly ball detent pin into each corner V-block to lock the two parts together.

Ensure the ball detent pin goes through the rigging bar and the other side of the transport rail.

**Refer to**

- *Transportation dollies, page 20*

**9.2.4****Landing arrays onto a dolly**

Landing the array elements directly onto a dolly makes transportation easier.

**Notice!****Dolly stacking limits**

X12T-DOLLY accommodates two columns of X1 or X2 loudspeaker systems stacked three high for transportation. The dolly is designed for a total of six loudspeakers per dolly.

X12-128-DOLLY accommodates one column of X12-128 subwoofers stacked two high for transportation. The dolly is designed for a total of two subwoofers per dolly.

X12-125F-DOLLY accommodates one column of X12-125F subwoofers stacked two high when both subwoofers are facing forward or three high when in cardioid configuration (two forward facing and one backward facing) for transportation.

**Notice!****Dolly wheel (the 4°) hole:**

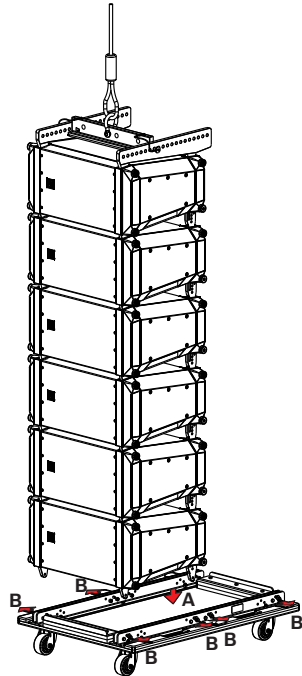
The bottom element to be landed on the dolly base must be pinned in the 4° hole (🔩) in the ANGLE SELECT section. Compress the rear link bars until they contact the angle select pin and lock by adding a second pin in the EVEN holes of the ANGLE LOCK section.

Ensure the two front link bars are lowered and locked.

**X12T-DOLLY:**

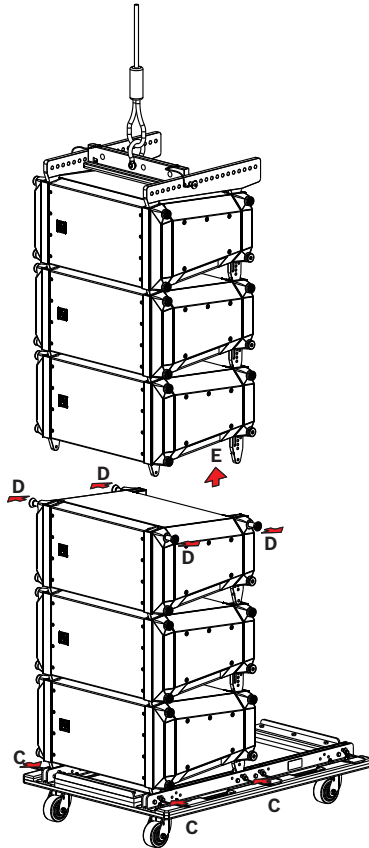
To land an array onto an X12T-DOLLY, do the following:

1. Lower the array (A) to a convenient working height above the floor.



2. If single pin compression method was used, carefully reverse the hoist and uncompress the back of the array so the hoist has no tension and all of the elements in the array have returned to the 0° position.  
OR  
If double pin method was used, lift up slightly on the rear of each of the bottom three elements and remove the quick-release pins from the lock holes. Gravity will cause the unlocked rigging splay to revert to 0° position.
3. If single, pin compression method was used, remove the bottom grid side arms.
4. On the bottom element, select 4° (🔒) in the Angle Select section on both sides.
5. Lift the link bars on the bottom element until they stop.
6. Lock the link bars in place at 4° by pinning them in the 0°/Even hole of the Angle Lock section.
7. Pin the element above at 0° on each side.
8. Disengage the eight dolly pins (B) on the dolly base.  
All eight dolly pins are disengaged and hanging from the dolly.
9. Verify the V-blocks are unobstructed and clear.
10. Position the empty dolly under the array.
11. Ensure grilles are facing out.
12. Lower the array until the link bars engage the V-blocks on the dolly.  
Guide the array to land the link bars onto the dolly rails.
13. Insert the four dolly pins (C) to lock the enclosures onto the dolly.

Verify the dolly pin is thoroughly pushed in and through both sides of the rail.



14. Pull and twist the four captive twist lock pins (D).  
All four captive twist lock pins now are in the unlock position.
15. Lift the remaining suspended enclosures (E).  
A single column of three elements is on the dolly.
16. Rotate the dolly.
17. Lower the array to a convenient working height above the floor.
18. Repeat steps 3-15 until all elements of the array are landed on dollies.
19. Install dolly side panels and dolly top for transport. See *X12T-DOLLY side panels and top cover*, page 25

**X12-125F-DOLLY:**

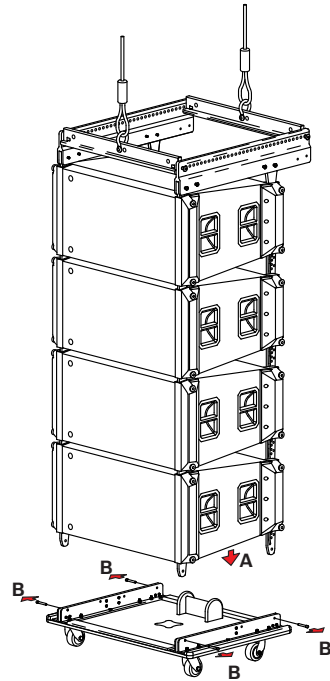
To land an X12-125F array onto an X12-125F-DOLLY, do the following:

1. Lower the array (A) to a convenient working height above the floor.
2. If single pin compression method was used, carefully reverse the hoist and uncompress the back of the array so the hoist has no tension and all of the elements in the array have returned to the 0° position.

OR

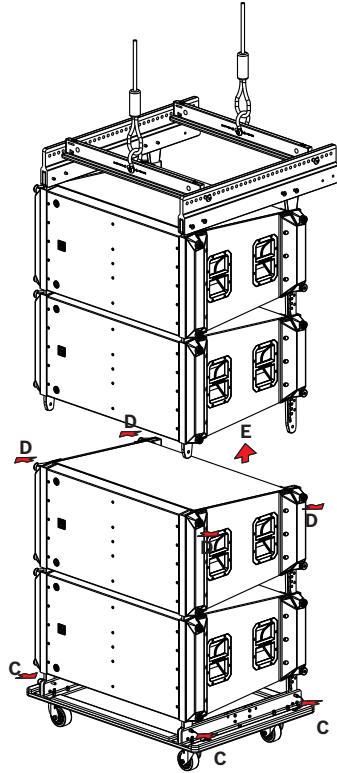
If double pin method was used, lift up slightly on the rear of each of the bottom two elements and remove the quick-release pins from the lock holes. Gravity will cause the unlocked rigging splay to revert to 0° position.

3. If single, pin compression method was used, remove the bottom grid side arms.
  4. On the bottom element, select 4° (⌚) in the Angle Select section on both sides.
  5. Lift the link bars until they stop.
  6. Lock the link bars in place at 4° by pinning them in the 0°/Even hole of the Angle Lock section.
  7. Pin the two elements above at 0° on each side.
  8. Disengage the four dolly pins (B) on the dolly base.
- All four dolly pins are disengaged and hanging from the dolly.



9. Verify the V-blocks are unobstructed and clear.
10. Position the empty dolly under the array.
11. Ensure grilles are positioned on the front side of the dolly.  
The X12-125F-DOLLY is designed for the X12-125F sub to be placed with the grilles positioned on the front side of the dolly.
12. Lower the array until the link bars engage the V-blocks on the dolly.  
Guide the array to land the link bars onto the dolly rails.
13. Insert the four dolly pins (C) to lock the enclosures onto the dolly.

Verify the pin is thoroughly pushed in and thorough both sides of the rail.



14. Pull and twist the four captive twist lock pins (D).  
All four captive twist lock pins now are in the unlock position.
15. Lift the column of enclosures (E).  
A single column of two elements is on the dolly.
16. Lower the array to a convenient working height above the floor.
17. Repeat steps 3-14 until all elements of the array are landed on dollies.
18. Install the X12-125F-DOLLY top cover for transportation. See *X12-125F-DOLLY top cover*, page 26



#### Notice!

Three X12-125F subwoofers in cardioid configuration may be landed and transported on the dolly as a single block.

#### Removing the grid



#### Caution!

The extended grid sidearms are heavy and likely to tip if not secured, potentially causing damage and/or personal injury if one should fall.

Always maintain a good grip on the sidearm until both twist-lock pins are fully engaged.

To remove the grid, do the following:

1. Remove the 5/8-inch shackle from the spreader bar(s).
2. Lift hoist motor to a safe height.
3. Remove spreader bar.
4. Pull and twist the four captive twist lock pins.  
All four captive twist lock pins now are in the unlock position.



- Remove the grid sidearms.

#### Refer to

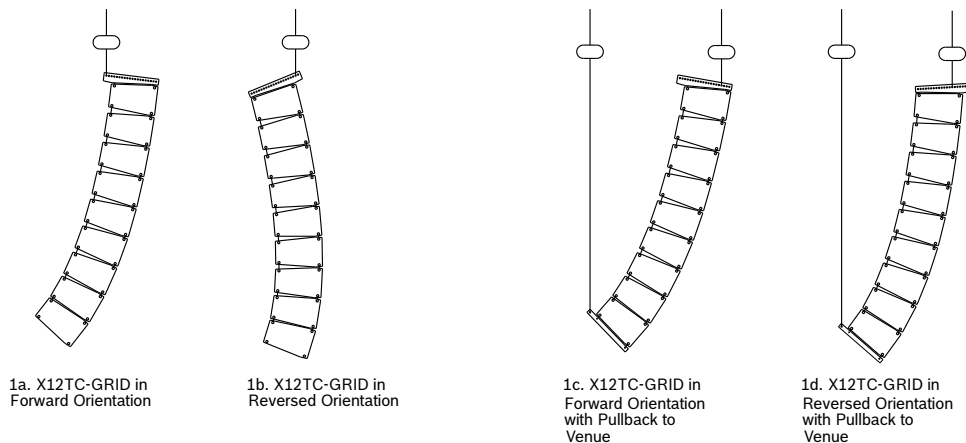
- *Transportation dollies, page 20*
- *X12T-DOLLY side panels and top cover, page 25*
- *X12-125F-DOLLY top cover, page 26*

## 9.3 Array building techniques

### 9.3.1

#### Multiple ways to fly the X12TC-GRID

X12TC-GRID can be flown in two different ways—with a single grid pick point and with a single grid pick point plus a pullback to the venue. Additionally, the grid has two orientations forward and reversed. In line array configuration software from Electro-Voice, the user must choose which way the grid will be flown, plus the orientation of the grid.



**Figure 9.8:** Flying the X12TC-GRID

#### Single grid pick point:

In the forward orientation (1a), a small section of the grid extends behind the rear of the loudspeaker, enabling more down tilt.

In the reversed orientation (1b), a small section of the grid extends in front of the loudspeaker, enabling more up tilt.

Choose the pick point on the grid to achieve the desired angle as reported by Electro-Voice line array configuration software.

Single grid pick point with a pullback to the venue:

A pullback to the venue is used when more down tilt is required than can be achieved by a single grid pick alone. The X12PU-BGK is used at the bottom of the array.

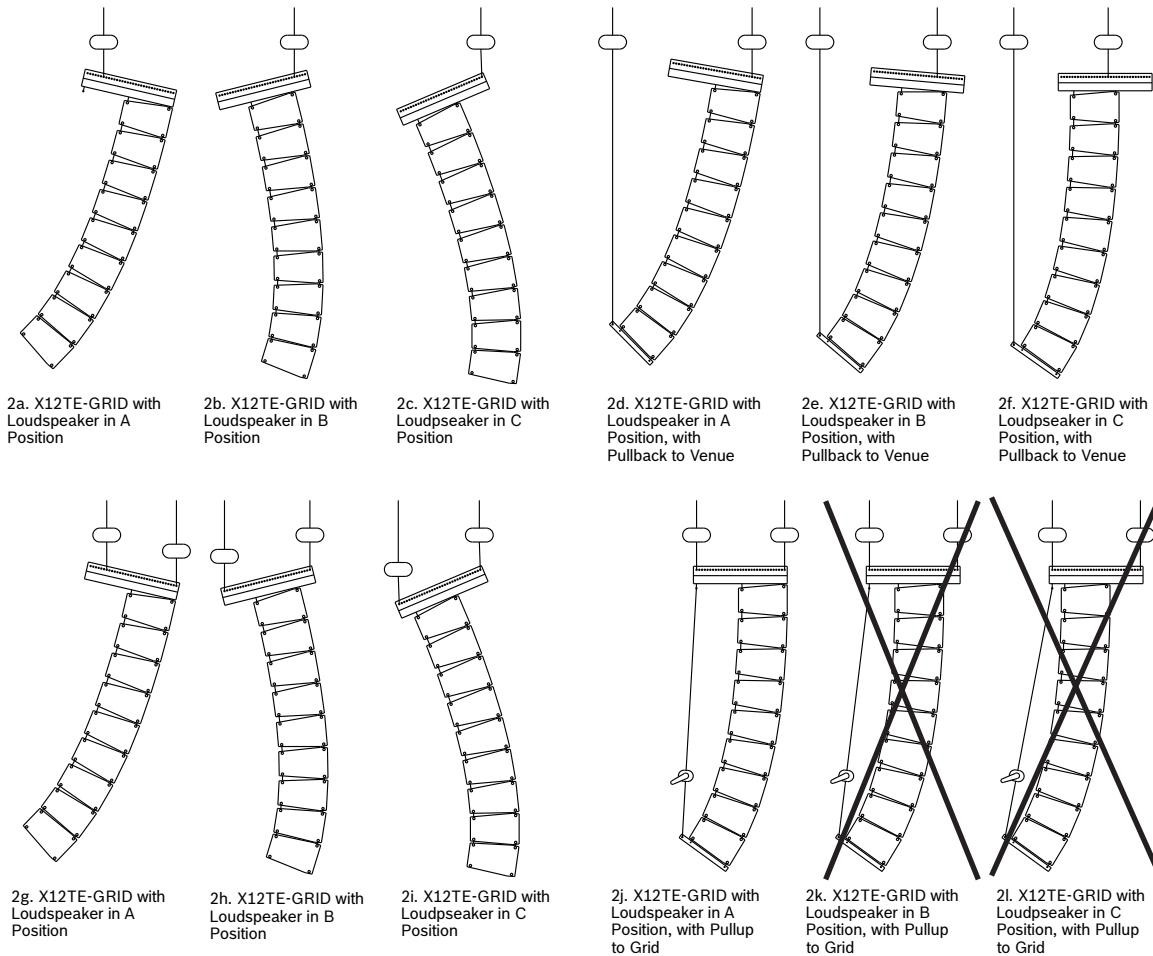
The most common orientation would be to use the grid in the forward position (1c).

The grid can also be used in the reversed orientation with a pullback to the venue (1d). The purpose of the pullback is to enable greater down tilt.

Choose a grid pick point near the front of the grid. This tilts the array up slightly, which makes it easier to build because the bottom of a flown element will be a closer match to the top element on a dolly stack.

### 9.3.2 Multiple ways to fly the X12TE-GRID

X12TE-GRID can be flown in four different ways—with a single grid pick point, with a single grid pick point plus a pullback to the venue, with two grid pick points, and with two grid pick points plus a pull-up to the grid. Additionally, the loudspeakers may be attached to the grid in three different positions. In line array configuration software from Electro-Voice, the user must choose which way the grid will be flown, plus the attachment position of the loudspeakers.



**Figure 9.9:** Flying the X12TE-GRID

#### Single grid pick point:

With the loudspeakers attached in the A position (2a), a large section of the grid extends behind the rear of the loudspeaker, enabling the maximum amount of down tilt.

With the loudspeakers attached in the B position (2b), a portion of the grid extends both behind and in front of the loudspeaker, enabling moderate tilt both up and down.

With the loudspeakers attached in the C position (2c), a large section of the grid extends in front of the loudspeaker, enabling the maximum amount of up tilt.

Choose the pick point on the grid to achieve the desired angle as reported by Electro-Voice line array configuration software.

#### Single grid pick point with a pullback to the venue:

A pullback to the venue should be used when more down tilt is required than can be achieved by a single grid pick alone. The X12PU-BGK is used at the bottom of the array.

The most common orientation would be to use the grid with the loudspeakers attached in the A position (2d).

A pullback to the venue can also be used with the loudspeakers attached in the B position (2e) or in the C position (2f). Choose a grid pick point near the front of the grid. This will tilt the array up slightly, which will make it easier to build because the bottom of a flown element will be a closer match to the top element on a dolly stack.

**Double grid pick points:**

Always attach the two grid pick points at the front-most and rear most attachment points on the grid.

With the loudspeakers attached in the A position (2g), the maximum down tilt can be obtained.

With the loudspeakers attached in the B position (2h), moderate down-tilt and up tilt can be obtained.

With the loudspeakers attached in the C position (2i), the maximum up tilt can be obtained.

The user must adjust the front and back hoist motors to achieve the angle reported by Electro-Voice line array configuration software.

**Double grid pick points plus a pull-up to the grid:**

Using a pull-up to the grid enables the loudspeaker to be lifted off the dollies with the elements hanging straight at 0°, then pull the elements to their correct angle using a hoist in the pull-up assembly.

The X12PU-BGK is used at the bottom of the array.

Always attach the two grid pick points at the front-most and rear most attachment points on the grid.

Always attach the loudspeakers in the A position, furthest away from the pick point (2j).

It is not recommended to use a pull-up to the grid with the loudspeakers in the B position (2k) or the C position (2l). Because the B and C positions are so close to the pull-up attachment point on the grid, excessive forces result in the pull-up assembly.

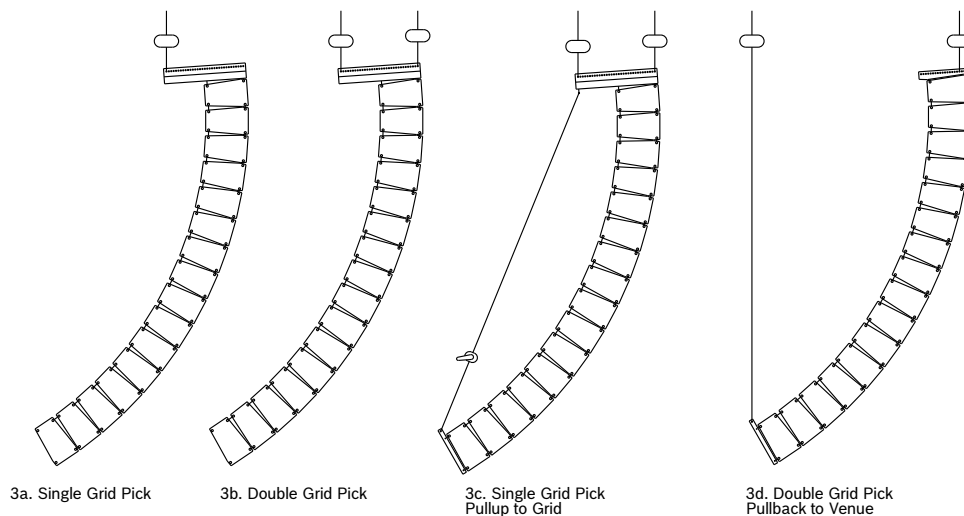
With large arrays, it is possible for a single grid pick point to be in a safe condition once the pull-up is pulled into compression, but the user would pass through an unsafe condition while building an array. Therefore we recommend using two grid pick points to avoid the possibility of an unsafe condition.

For large arrays, the force required to pull the rear rigging of all elements into compression may exceed the pull-up assembly maximum rating. If this occurs, it may be necessary to pin several elements at the top of the array at fixed angles. If so, Electro-Voice line array configuration software will return a message telling the user how many elements to fixed pin.

**9.3.3****Array build strength considerations**

Line array configuration software from Electro-Voice reports when the working-load limits for any of the elements in the array are exceeded. Having an understanding of the structural advantages and disadvantages of different array build configurations allows the user to select the best option to meet their needs.

Comparing array structure strengths shows the same array constructed in four different ways: single grid pick point, double grid pick points, double grid pick points with a pull-up to the grid, and single pick point with a pullback to venue. Because the array construction is different, the forces throughout the array are different. This results in different structural ratings.



**Figure 9.10:** Comparing array structural strengths

The arrays in Figures 3a and 3b are the weakest. The highest force in both of these arrays will be on the rear rigging points of the top element. The long length of the X12TE-GRID extended behind the loudspeaker acts as a large lever arm (like a wrench) that significantly increases the force on the top enclosure rear rigging. Another way to visualize this is to think of the grid being held in a fixed position. Because the center of gravity of the entire loudspeaker column is so far towards the back, the column will tend to rotate counterclockwise to tilt up. The rear rigging of the top enclosure will be in tension resisting the rotation.

Whenever a large portion of grid is extended behind the top loudspeaker as shown in Figures 3a and 3b, fewer elements will be allowed to be suspended before the working-load limit of the top element rear rigging is exceeded. This condition most commonly occurs with the X12TE-GRID when the loudspeakers are in the A position. The same condition can occur when a large portion of grid is extended in front of the top loudspeaker. This could occur with a steep up-tilt angle with the X12TE-GRID with the loudspeakers in the C position on the grid. The X12TC-GRID is not subject to this condition, because the grid is just slightly longer than the loudspeaker enclosures.

The array in Figure 3d is the strongest because the load is shared between the top and bottom of the array. This configuration will allow the highest number of elements to be suspended and is most commonly employed when a greater down-tilt angle is required.

Unless extreme down-tilt angles are employed, the highest forces in the array in Figure 3d will be on the rigging of the top element. The X12PU-BGK bottom grid does not have as high of a strength rating as the top grids X12TC-GRID or X12TE-GRID.

The array configuration shown in Figure 3c has greater capability than those shown in Figure 3a and 3b, but less capability than the array shown in Figure 3d. In this case, the load of the loudspeaker column is shared between the rigging attachment points of the top element and the pull-up assembly. However, the pull-up to the grid introduces forces that otherwise would not exist due to gravity alone. For the array configuration in Figure 3c, the highest forces typically occur at either the top element or at one of the elements near the bottom of the array.

## 10

### 10.1

## Rigging structural strength ratings and safety factors

### Structural introduction

The X1, X2 and X12-125F loudspeaker systems, grids, and accessories were designed as a complete system to ensure safety and compatibility. The maximum possible number of X1 or X2 loudspeaker systems that may be suspended in a single column is 24 while maintaining an 8:1 safety factor. The maximum possible number of X12-125F subwoofer systems that may be suspended in a single column while maintaining an 8:1 safety factor is nine using the center pick point on an X12-125F-GRID spreader bar and 18 if the spreader bar is bridled to the two outer attachment holes.

The actual forces on the rigging components within an array will depend on the specific configuration of the loudspeakers and grids. The tilt angles of the individual elements, grids and the entire array will change the forces in the rigging components throughout an array. Pick points from the grid, pull backs to the venue, and pull ups to the grid will also affect load distribution. The result is that the actual maximum number of X1 and X2 systems will be dependent on the array configuration.

All components are included as part of the line array configuration software from Electro-Voice. The software calculates the forces throughout the array and informs the user of the limitations. Electro-Voice line array configuration software also reports the loads for the pick points going to the venue.

#### Refer to

– *Working-load limit and safety factor definitions, page 71*

### 10.2

### Structural rating overview

Designing a safe structural array is a very complex process best left to experienced professionals. There are two independent strength considerations, together, that give a complete description of the overall structural capabilities of any loudspeaker system; these are:

1. The strength of each individual enclosure rigging point; which is the combined strength of the rigging bar channels, hinge bars, link bars, quick-release rigging pins internal rigging straps, external tie plates, bolts, and enclosure.
2. The total strength of the overall array; which is a function of the combined forces from all of the rigging points acting on the rigging components and the array as a whole.

For grids, there are two independent strength considerations, which together, give a complete description of the overall structural capabilities of the grid; these are:

1. The strength of each individual grid rigging point; which is the combined strength of the bolts, grid side arms, spreader bars, and quick-release pins.
2. The total strength of the overall grid; which is a function of the combined forces from all of the rigging points acting on the rigging components, and the grid as a whole.

In any system loudspeaker array, the forces acting on each loudspeaker system (on each individual rigging point and on the overall enclosure) and the forces acting on each grid rigging accessory (on each sidearm and spreader bar and on the overall grids and spreader bars) vary with each array configuration. Determining those forces throughout an array requires complex mathematical calculations.

To make the X1, X2 and X12-125F systems both safe and easy to use, Electro-Voice engineers have built calculations into Electro-Voice line array configuration software, enabling a user to immediately determine if an array is safe without having to do a complex structural analysis.

## 10.3 Electro-Voice line array configuration software structural evaluations simplified structural rating guidelines

Using a combination of computer modeling, destructive and non-destructive testing, Electro-Voice engineers have developed calculations to determine the forces within an array that act on the loudspeaker systems and grid rigging accessories. The results of these calculations are compared to the working-load limits of each loudspeaker and grid element, and their individual components.

Electro-Voice line array configuration software will take into account all the complex factors to ensure that an array is strong enough to maintain an 8:1 safety factor. If a particular array designed by a user exceeds a working-load limit, the software will return warning messages. The messages will provide information describing what is causing the overload, and will offer suggestions to the user for changes that can be made to the array to eliminate the overload. The user can then decide the best solution for their particular application.

The line array configuration software will also report the loads on the rigging pick points (typically hoist motors) that suspend the array from the venue. The software assumes that these rigging points are plumb vertical. The user must calculate the increased tension in the suspension lines if they are angled.



### Caution!

The user should never apply a load that exceeds the working-load limits of any of the rigging components or complete loudspeaker systems described in this manual.

The user should never exceed the safety limitations reported by Electro-Voice line array configuration software.

## 10.4 Specific safety considerations

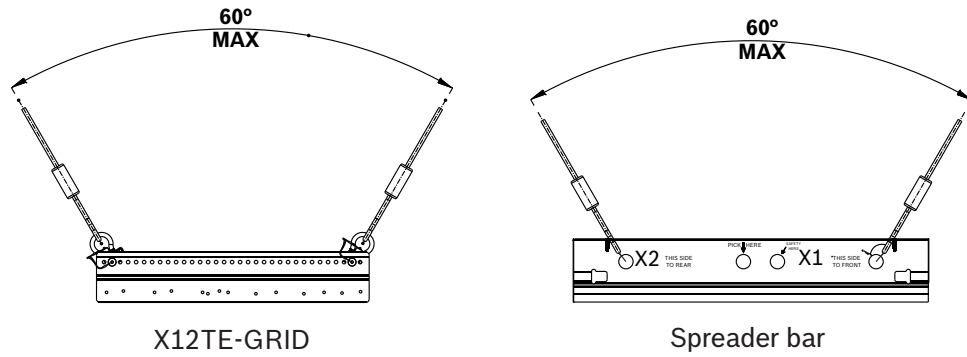
### X1, X2 and X12-125F loudspeaker systems

The X1 and X2 loudspeaker systems must only be suspended using the Electro-Voice grids. The X12TC-GRID and X12TE-GRID grid are for use with X1 and X2 loudspeakers. The X12-125F-GRID is for use with X12-125F subwoofers. For a pull back to a venue or a pull up to grid, use the X12PU-BGK as the bottom grid for X1 and X2 loudspeakers. The X12-125FPU-BGK is for use with the X12-125F-GRID for X12-125F subwoofers.

The X1, X2 and X12-125F rigging and grids were designed to be tilted up or down (front to back tilt). However, they are not intended to hang sideways. Columns of X1 or X2 loudspeaker systems must never be angled off hanging plumb vertical  $\pm 5^\circ$ .

### X12TC-GRID, X12TE-GRID and X12-125F-GRID top grids

The X12TC-GRID, X12TE-GRID and X12-125F-GRID top grids may be suspended using one or two spreader bars. Additionally, one or two pick points may be used with the spreader bars. When multiple pick points are used to suspend the grids from a venue roof, line array configuration software calculates the loads on the pick points assuming that the suspension lines are plumb vertical. If the lines are angled, the loads will be increased on both the grid and hoist motors and building supports. The user is responsible for determining the resulting increased loads. When suspending the X12TC-GRID, X12TE-GRID and X12-125F-GRID top grids with multiple pick points, the pick lines must be plumb vertical  $\pm 30^\circ$ .



**Figure 10.1:** Double pick point maximum angle

**X12PU-BGK and X12-125FPU-BGK bottom pull-up grid**

The X12PU-BGK and X12-125FPU-BGK bottom grids were designed to have a pick angle that varies front to back for tilting an array down, but was not intended for side pulls. The X12PU-BGK is only rated over side-to-side pull angles of  $\pm 5^\circ$ .

Line array configuration software reports the tension required to pull the rear rigging of the loudspeaker enclosures into compression when the X12PU-BGK is used with the X12TE-GRID and the X12-125FPU-BGK is used with the X12-125F-GRID. Never exceed the tension reported by Electro-Voice line array configuration software.

Line array configuration software calculates the loads on the X12PU-BGK and X12-125FPU-BGK when used as a pull up/back to the venue assuming that the suspension lines are plumb vertical. If the line is not vertical, the loads will be different than the calculated value. The user is responsible for determining the load when not vertical.

The X12PU-BGK and X12-125FPU-BGK are intended to be used as bottom grids for pull-up applications only. Never use X12PU-BGK or X12-125FPU-BGK as a top grid.

**10.5**

**Working-load limit and safety factor definitions**

The structural ratings for all of the X-Line Advance series rigging components and complete loudspeaker systems are based on test results in which parts were stressed to failure.

Manufacturers typically present the structural-strength ratings of mechanical components or systems as either the working-load limit (WLL) or the ultimate-break strength. Electro-Voice chooses to present the structural-load ratings as the working-load limit. The working-load-limit rating represents the maximum allowable load to be applied to a mechanical component or system.

The working-load limits for the X1, X2 and X12-125F systems, grids, accessories, and complete arrays described in this manual are based on a minimum 8:1 safety factor. The safety factor is defined as the ratio of the ultimate-break strength divided by the working-load limit, where the ultimate-break strength represents the force at which a part structurally fails. For example, if a part has a working-load limit of 1,000 lb (454 kg), it would not structurally fail until a force of at least 8,000 lb (3,629 kg) was applied, based on an 8:1 safety factor. However, the user should never apply a load to that part that exceeds 1,000 lb (454 kg). The safety factor provides a margin of safety above the working-load limit to accommodate normal dynamic loading and normal wear.

**Cautions for working-load limits and safety factors**

The working-load limits defined by the manufacturer of any rigging component should never be exceeded. Electro-Voice bases the working-load limits of its X1, X2 and X12-125F products on a minimum of an 8:1 safety factor. Other manufacturers of rigging components may base

their working-load limits on safety factors other than 8:1. For example, 5:1 safety factors are fairly common amongst rigging manufacturers because many regulatory agencies call for a minimum safety factor of 5:1.

When an X1, X2 or X12-125F system is installed where local regulations only require a safety factor of 5:1, Electro-Voice insists the working-load limits of the X1, X2 or X12-125F rigging is never exceeded and an 8:1 safety factor be maintained for the X1, X2 and X12-125F loudspeakers.

The user is cautioned that some local regulations may require safety factors higher than 8:1. Electro-Voice insists the user maintain the higher safety factor as required by the local regulations throughout the entire X1, X2 and X12-125F installation. It is the responsibility of the user to ensure any X1, X2 or X12-125F system installation meets all applicable local, state or federal safety regulations.



## 11 Rigging inspection and precautions

**Loudspeaker systems:** Prior to each use, inspect the enclosures for any cracks, deformations or missing or damaged components that could reduce enclosure strength. Inspect the rigging pins, hinge bars, linking bars and rigging channel bars for cracks, corrosion or other deformations that could reduce their strength and integrity. Hardware that is bent or showing signs of more than cosmetic surface corrosion should be replaced immediately.

**Grids:** Prior to each use, inspect the grid side arms, spreader bars, linking bars, and rigging pins for any cracks, corrosion, missing or damaged parts or any other deformation that could reduce their strength and integrity.

Verify there are no missing rigging pins and all lanyards are securely attached. Hardware that is bent or showing signs of more than cosmetic surface corrosion should be replaced immediately.

**Lifting hoists:** Prior to each use, inspect the lifting hoist(s) and associated hardware (including motor(s), if applicable) for any cracks, deformation, broken welds, corrosion, missing or damaged components that could reduce the hoist strength. Replace any damaged hoists. Never exceed the limitations or maximum recommended load specified by the hoist manufacturer. Always follow manufacturers' recommendations for operation, inspection, and certification. Always raise and lower the load slowly and evenly, avoiding any rapid changes in speed or shifting loads that could result in a sudden jolt to the suspended system or the structure from which it is suspended.

**Building, tower or scaffold supports:** Prior to each use, the strength and load-bearing capabilities of the building, tower or scaffold structural supports should be evaluated and certified by a professional engineer as being adequate for supporting the intended rigging system (including the loudspeakers, grids, chain hoists, and all associated hardware). Prior to each use, inspect the building, tower or scaffold structural supports for any cracks, deformation, broken welds, corrosion, missing or damaged components that could reduce the structural strength. Damaged structural supports should be replaced or repaired and recertified by a professional engineer. Never exceed the limitations or maximum recommended load for the supports.

**Miscellaneous mechanical components:** Prior to each use, inspect all mechanical components (chain, wire ropes, slings, shackles, hooks, fittings, ratchet straps, etc.) for any cracks, deformation, broken welds, slipping crimps, fraying, abrasion, knots, corrosion, chemical damage, loose screws, missing or damaged components that could reduce the maximum strength specified by the component manufacturer. Replace any damaged mechanical components immediately. Never exceed the limitations or maximum recommended load for the mechanical components.

## 12 Technical data

### X1-212/90 and X2-212/90

	X1-212/90	X2-212/90
Frequency Response (-3 dB) <sup>1</sup> :	57 Hz - 16 kHz	52 Hz - 19 kHz
Horizontal Coverage:	90°	
Vertical Coverage:	Array dependent	
Rec. High-Pass Frequency:	50 Hz	
Max Calculated SPL <sup>2</sup> :	143 dB Peak	146 dB Peak
Configuration:	Passive, Bi-amp	Bi-amp
Passive Crossover Freq.:	1600 Hz	NA
Passive Axial Sensitivity <sup>4</sup> :	98 dB (1 W/1 m)	NA
Passive Power Handling <sup>5</sup> :	500 W Continuous, 2000 Peak	NA
Passive Impedance:	8 Ω (nominal, 6.4Ω (min))	NA
LF Transducer:	SMX2121, 12-in (305 mm) driver	DVN3125, 12-in (305 mm) driver
LF Axial Sensitivity <sup>4</sup> :	98 dB (1 W/1 m)	101 dB (1 W/1 m)
LF Power Handling:	400 W Continuous, 1600 W Peak	500 W Continuous, 2000 W Peak
LF Impedance:	8 Ω (nominal), 6.1 Ω (min)	
HF Transducer:	2 x ND2R, 2-in (51 mm) diaphragm compression driver	2 x ND6A, 3-in (76.2 mm) diaphragm compression driver
HF Axial Sensitivity <sup>4</sup> :	110 dB (1 W/1 m)	112 dB (1 W/1 m)
HF Power Handling <sup>3</sup> :	120 W Continuous, 480 W Peak	150 W Continuous, 600 W Peak
HF Impedance:	8 Ω (nominal), 6.0 Ω (min)	
Rigging Angles:	0°, 0.5°, 1°, 1.5°, 2°, 3°, 4°, 5°, 6°, 8°, 10°	
Connectors:	Dual NL8 type connector	
Enclosure:	13-ply weather resistant birch with EVCoat	
Grille:	16 GA powder coated galvanized	
Suspension:	IRS — Integrated Rigging System	
Dimensions (H x W x D):	13.5 in x 28.77 in x 12.04 in (342.9 mm x 730.8 mm x 534.4 mm)	
Net Weight:	92 lb (41.7 kg)	93 lb (42.2 kg)
Shipping Weight:	106 lb (48 kg)	107 lb (48.5 kg)

<sup>1</sup>Full-space anechoic array performance with FIR-Drive preset.

<sup>2</sup>Full-space measurement of HF section of 4 elements. SPL adjusted for 1m distance.

<sup>3</sup>AES 2-1984 and ANSI S4.26-1984 power test.

<sup>4</sup>Full-space anechoic measurement of a single element.

<sup>5</sup>EIA/ANSI RS-426A.

**X1-212/120 and X2-212/120**

	<b>X1-212/120</b>	<b>X2-212/120</b>
Frequency Response (-3 dB) <sup>1</sup> :	57 Hz - 16 kHz	52 Hz - 19 kHz
Horizontal Coverage:	120°	
Vertical Coverage:	Array dependent	
Rec. High-Pass Frequency:	50 Hz	
Max Calculated SPL <sup>2</sup> :	142 dB Peak	145 dB Peak
Configuration:	Passive, Bi-amp	Bi-amp
Passive Crossover Freq.:	1600 Hz	NA
Passive Axial Sensitivity <sup>4</sup> :	98 dB (1 W/1 m)	NA
Passive Power Handling <sup>5</sup> :	500 W Continuous, 2000 Peak	NA
Passive Impedance:	8 Ω (nominal), 6.4Ω (min)	NA
LF Transducer:	SMX2121, 12-in (305 mm) driver	DVN3125, 12-in (305 mm) driver
LF Axial Sensitivity <sup>4</sup> :	98 dB (1 W/1 m)	101 dB (1 W/1 m)
LF Power Handling <sup>3</sup> :	400 W Continuous, 1600 W Peak	500 W Continuous, 2000 W Peak
LF Impedance:	8 Ω (nominal), 6.1 Ω (min)	
HF Transducer:	2 x ND2R, 2-in (51 mm) diaphragm compression driver	2 x ND6A, 3-in (76.2 mm) diaphragm compression driver
HF Axial Sensitivity <sup>4</sup> :	109 dB (1 W/1 m)	111 dB (1 W/1 m)
HF Power Handling <sup>3</sup> :	120 W Continuous, 480 W Peak	150 W Continuous, 600 W Peak
HF Impedance:	8 Ω (nominal), 6.0 Ω (min)	
Rigging Angles:	0°, 0.5°, 1°, 1.5°, 2°, 3°, 4°, 5°, 6°, 8°, 10°	
Connectors:	Dual NL8 type connector	
Enclosure:	13-ply weather resistant birch with EVCoat	
Grille:	16 GA powder coated galvaneal	
Suspension:	IRS — Integrated Rigging System	
Dimensions (H x W x D):	13.5 in x 28.77 in x 12.04 in (342.9 mm x 730.8 mm x 534.4 mm)	
Net Weight:	92 lb (41.7 kg)	93 lb (42.2 kg)
Shipping Weight:	106 lb (48 kg)	107 lb (48.5 kg)

<sup>1</sup>Full-space anechoic array performance with FIR-Drive preset.

<sup>2</sup>Full-space measurement of HF section of 4 elements. SPL adjusted for 1m distance.

<sup>3</sup>AES 2-1984 and ANSI S4.26-1984 power test.

<sup>4</sup>Full-space anechoic measurement of a single element.

<sup>5</sup>EIA/ANSI RS-426A.

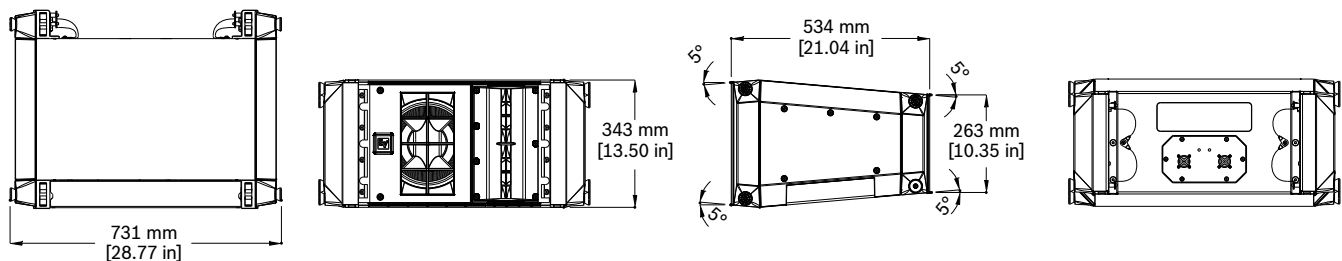
**X12-125F and X12-128**

	<b>X12-125F</b>	<b>X12-128</b>
Frequency Response (-3 dB) <sup>1</sup> :	36-215 Hz	27-200 Hz
Frequency Response (-10 dB) <sup>1</sup> :	29-1650 Hz	23-1950 Hz
Coverage (H x V):	Omni directional	
Rec. High-Pass Frequency:	33 Hz	27 Hz
Max Calculated SPL <sup>1</sup> :	134 dB Continuous, 140 dB Peak	138 dB Continuous, 144 dB Peak
Configuration:	Parallel Mode: Both woofers are internally wired in parallel on Pins 1+/1- Dual Mode: Each woofer is wired separately on Pins 1+/1- and 2 +/2-	
Axial Sensitivity <sup>1</sup> :	99 dB (1 W/1 m)	102 dB (1 W/1 m)
Passive Power Handling <sup>2</sup> :	3000 W Continuous, 12,000 W Peak	4000 W Continuous, 16,000 W Peak
Impedance:	(1) 4 ohm (Parallel Mode), (2) 8 ohm (Dual Mode)	
LF Transducer:	2 x 15 in HWNS4158	2 x 18 in DVF4180
Rigging Angles:	0°, 1°, 2°, 3°, 4°, 5°, 6°, 8°, 10°	NA
Maximum array:	18 elements	NA
Connectors:	(4) NL8 type connectors (Two in front and two in back)	
Enclosure:	13-ply weather resistant birch with EVCoat, internally braced	
Grille:	14 GA powder coated galvanized	
Dimensions (H x W x D):	20.50 in x 43.44 in x 30.51 in (52.07 cm x 110.34 cm x 77.50 cm)	20.375 in x 43.500 in x 29.875 in (51.75 cm x 110.49 cm x 75.88 cm)
Net Weight:	198 lb (89.8 kg)	195 lb (88.45 kg)
Shipping Weight:	210 lb (195.3 kg)	205 lb (93.2 kg)

<sup>1</sup>Half-space anechoic measurement of single element.

<sup>2</sup>AES 2-1984 power test.

## 12.1 Dimensions



**Figure 12.1:** Dimensions: X1-212/90 & X1-212/120

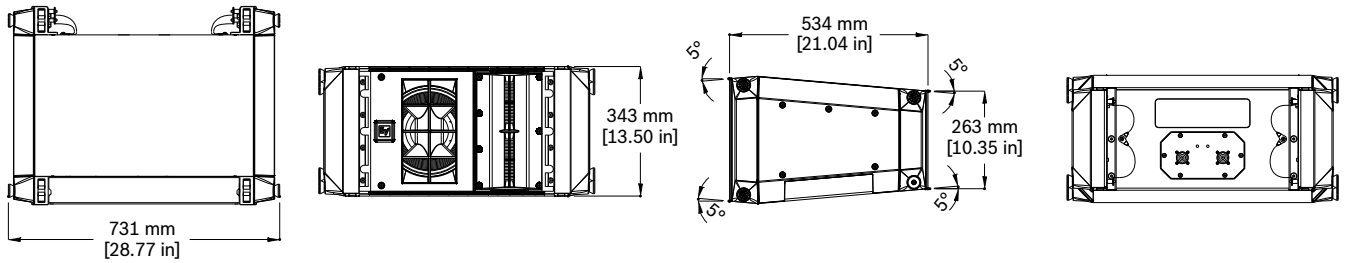


Figure 12.2: Dimensions: X2-212/90 & X2-212/120

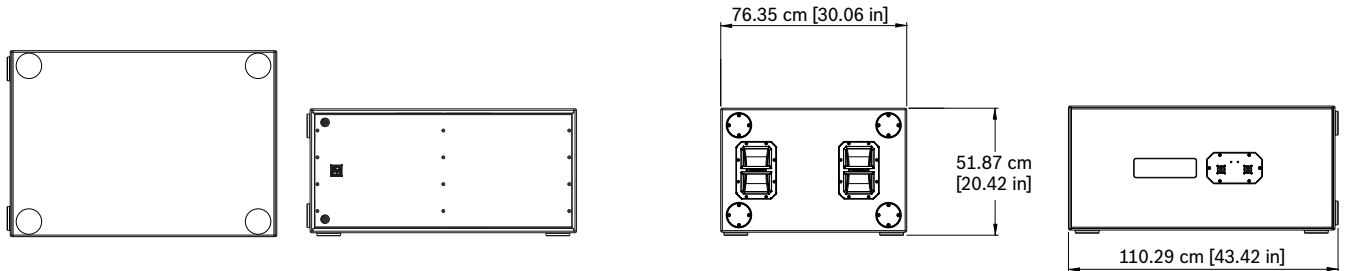


Figure 12.3: Dimensions: X12-128

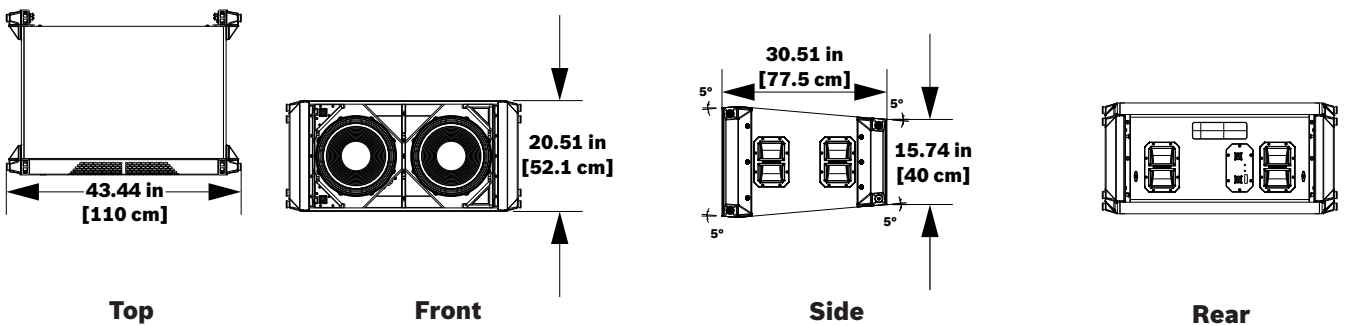


Figure 12.4: Dimensions: X12-125F

## 12.2 Accessories

### 12.2.1 Accessories technical data

#### Grids

##### X12TC-GRID compact grid

Color:	Black
Dimensions (H x W x D):	177 mm x 610 mm x 631 mm (7.0 in x 24.0 in x 24.8 in)
Net weight:	24.7 lb (11.2 kg)
Shipping weight:	26.0 lb (11.8 kg)

##### X12TE-GRID extended grid

Color:	Black
Dimensions (H x W x D):	267 mm x 610 mm x 1029 mm (10.5 in x 24.0 in x 40.5 in)

Net weight:	78.5 lb (35.6 kg)
Shipping weight:	82.0 lb (37.2 kg)

**X12PU-BGK pull up bottom grid kit**

Color:	Black
Dimensions (H x W x D):	102 mm x 587 mm x 631 mm (4.0 in x 23.1 in x 24.8 in)
Net weight:	36.7 lb (16.6 kg)
Shipping weight:	39.0 lb (17.7 kg)

**X12-125F-GRID grid for X12-125F flying subwoofer**

Color:	Black
Dimensions (H x W x D):	343 mm x 1011 mm x 1029 mm (13.5 in x 39.8 in x 40.5 in)
Net weight:	96.6 lb (43.8 kg)
Shipping weight:	107.6 lb (48.8 kg)

**X12-125F-AG adapter for X1/X2 to X12-125F subwoofer**

Color:	Black
Dimensions (H x W x D):	178 mm x 996 mm x 763 mm (7.0 in x 39.2 in x 30.0 in)
Net weight:	60.3 lb (27.4 kg)
Shipping weight:	74.5 lb (34.3 kg)

**X12-125FPU-BGK pull up grid kit for X12-125F subwoofer**

Color:	Black
Dimensions (H x W x D):	102 mm x 1011 mm x 930 mm (4.0 in x 39.8 in x 36.6 in)
Net weight:	68.2 lb (30.9 kg)
Shipping weight:	79.6 lb (36.1 kg)

**Grille kit for X12-125F-CGK as cardioid element**

Color:	Black
Dimensions (H x W x D):	411 mm x 969 mm x 79 mm (16.2 in x 38.2 in x 3.1 in)
Net weight:	10.9 lb (4.9 kg)
Shipping weight:	17.2 lb (7.8 kg)

**Dollies**

**X12T-DOLLY loudspeaker dolly for X1 or X2**

Color:	Black
Dimensions (H x W x D):	283 mm x 800 mm x 1143 mm (11.14 in x 31.5 in x 45 in)
Net weight:	168 lb (76.2 kg)
Shipping weight:	184 lb (83.5 kg)

**X12-128-DOLLY subwoofer dolly**

Color:	Black
Dimensions (H x W x D):	260 mm x 813 mm x 1143 mm (10.24 in x 32 in x 45 in)
Net weight:	110 lb (49.9 kg)
Shipping weight:	125 lb (56.7 kg)

**X12-125F-DOLLY dolly for X12-125F flying subwoofer**

Color:	Black
Dimensions (H x W x D):	492.5 mm (19.4 in) x 1143.0 mm (45.0 in) x 812.8 mm (32.0 in)
Net weight:	127.3 lb (57.7 kg)
Shipping weight:	143.4 lb (65.0 kg)

**X12-125F-DOK outrigger kit for X12-125F-DOLLY**

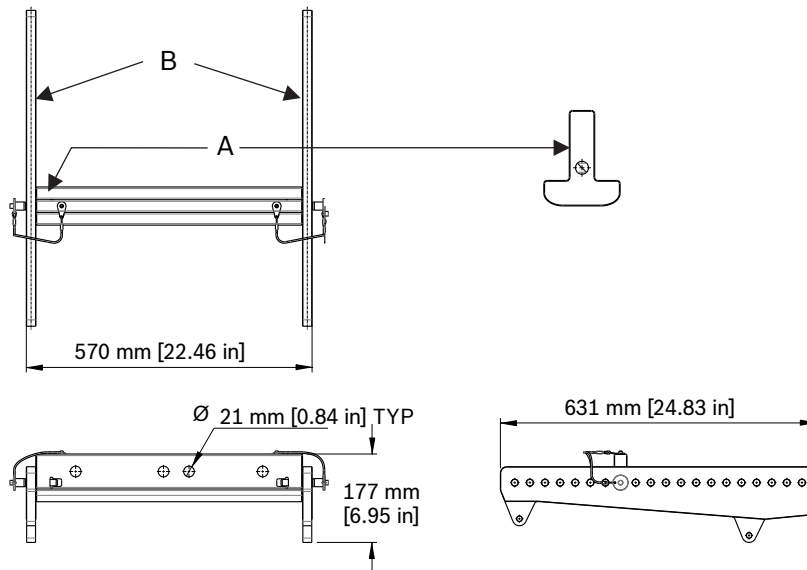
Color:	Red
Dimensions (H x W x D):	465 mm x 152 mm x 843 mm (18.3 in x 6.0 in x 33.2 in)
Net weight:	8.50 kg (18.75 lb)
Shipping weight (pair):	21.50 kg (47.50 lb)

**X12-125F-DAK dolly adapter kit for X12-125F-DOLLY**

Color:	Black
Dimensions (H x W x D):	61.21 mm x 101.60 mm x 152.40 mm (2.4 in x 4.0 in x 6.0 in)
Net weight:	8.0 lb (3.6 kg)
Shipping weight:	9.5 lb (4.3 kg)

## 12.2.2 Accessories dimensions

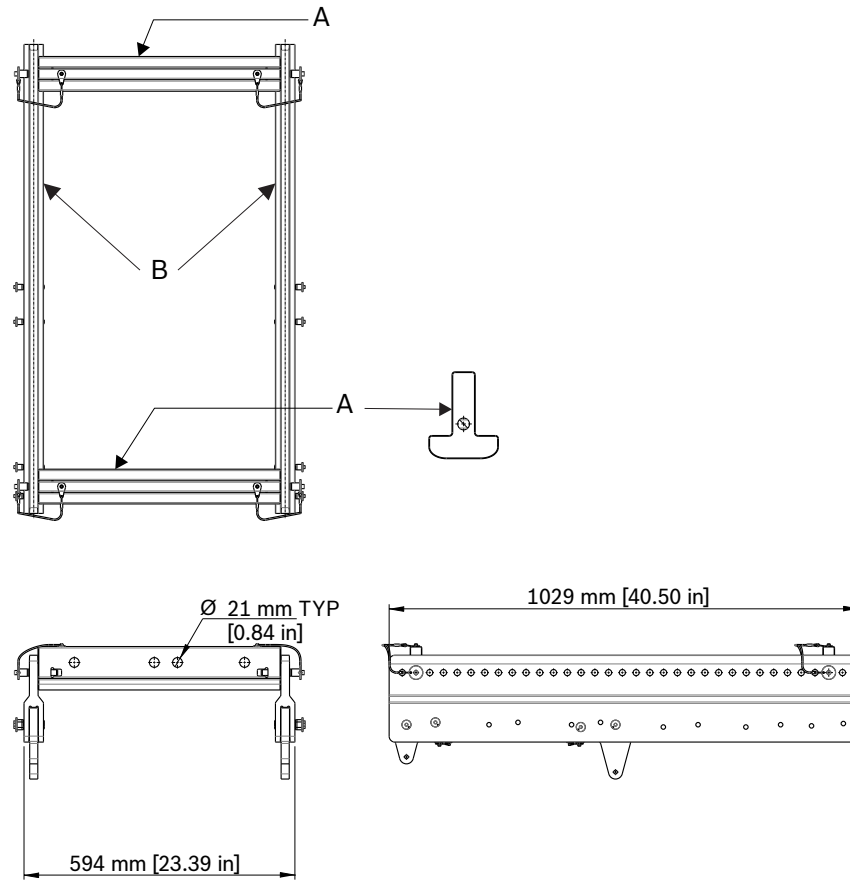
### Grids



**Figure 12.5:** Dimensions: X12TC-GRID compact grid

Letter	Description
A	Spreader bar assembly
B	Compact grid side bar assemblies





**Figure 12.6:** Dimension: X12TE-GRID extended grid

Letter	Description
A	Spreader bar assemblies
B	Top grid side bar assemblies

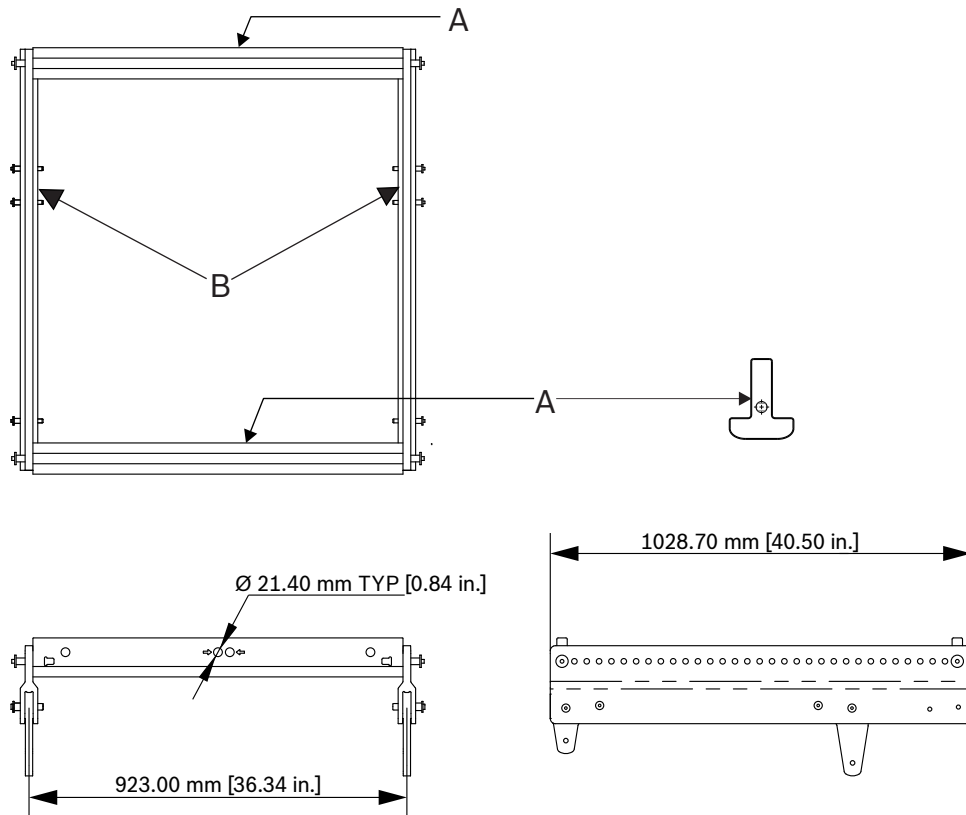


Figure 12.7: Dimensions: X12-125F-GRID flying subwoofer grid

Letter	Description
A	Spreader bar assemblies
B	Top grid side bar assemblies

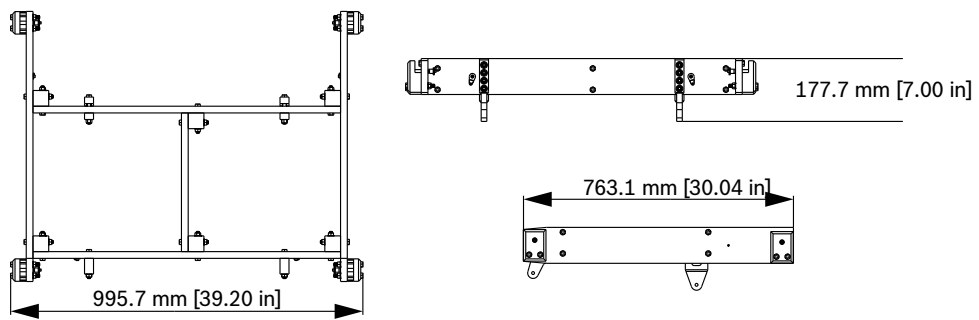


Figure 12.8: Dimensions: X12-125F-AG adapter grid

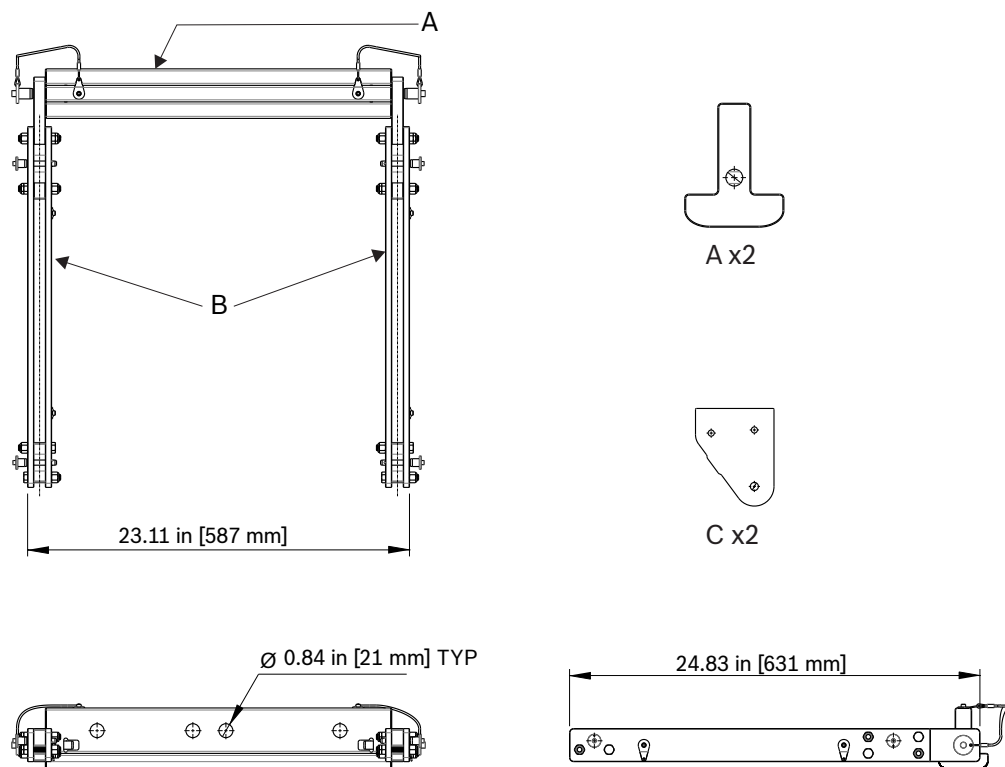


Figure 12.9: Dimensions: X12PU-BGK pull-up bottom grid kit

Letter	Description
A	Spreader bar assemblies
B	Pull-up side arm assemblies
C	Main grid rear pull-up link assemblies

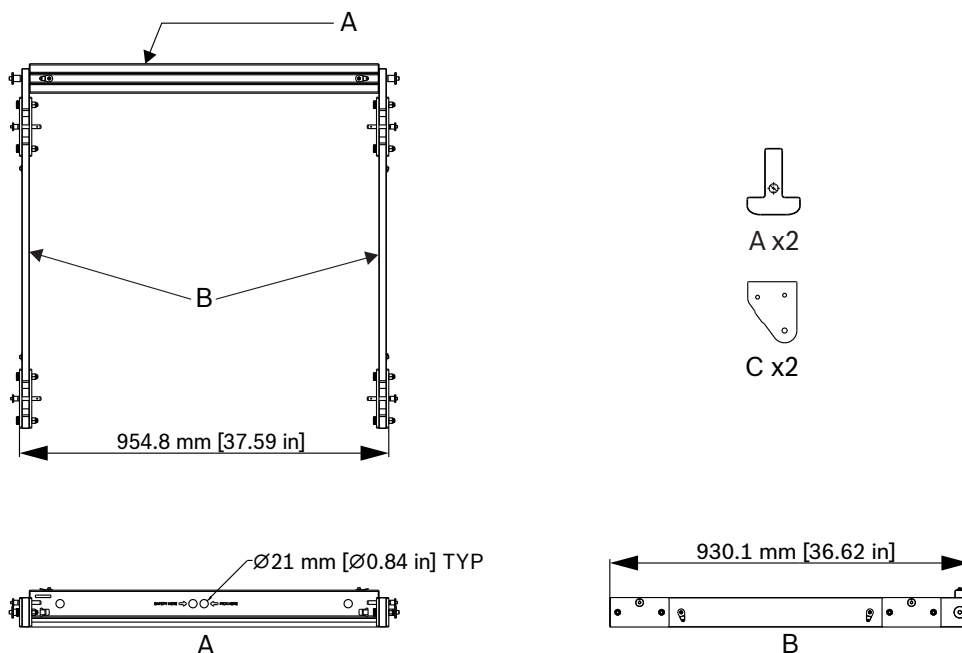


Figure 12.10: Dimensions: X12-125FPU-BGK flying subwoofer pull-up grid

Letter	Description
A	Spreader bar assemblies
B	Pull-up side arm assemblies
C	Main grid rear pull-up link assemblies

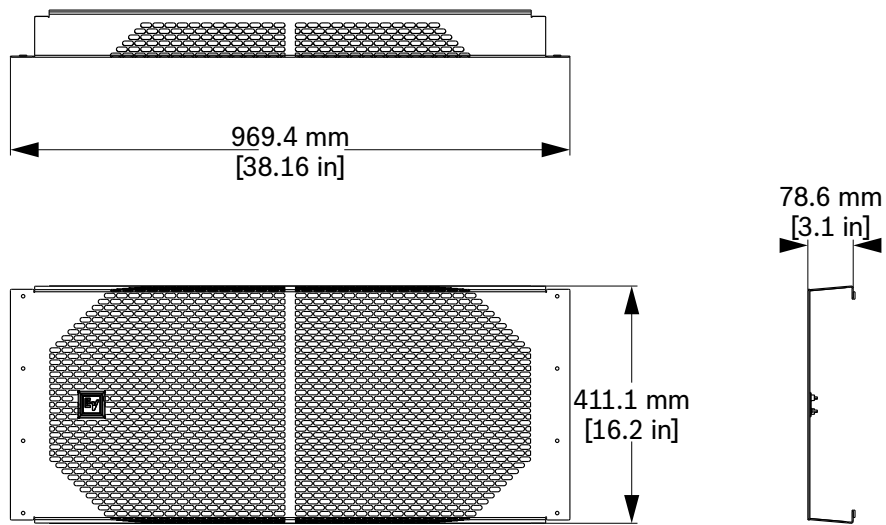


Figure 12.11: Dimensions: X12-125F-CGK cardioid grill kit

**Dollies**

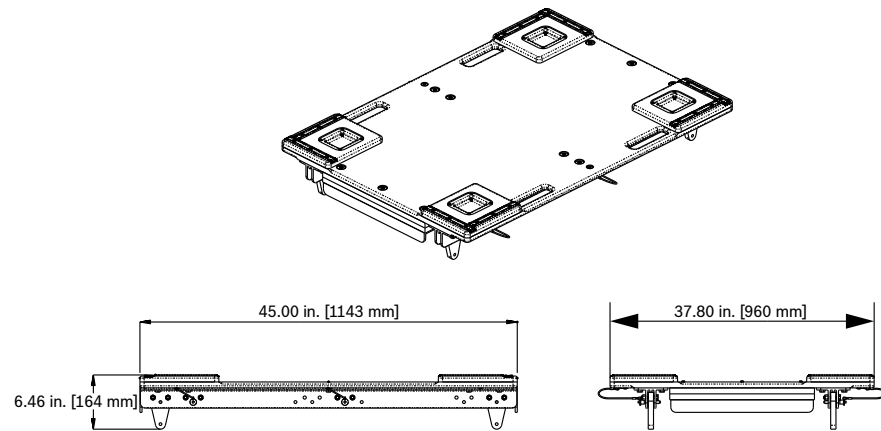
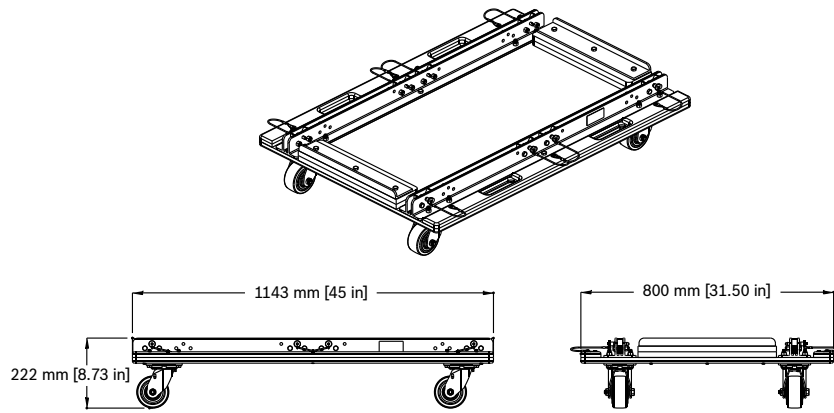
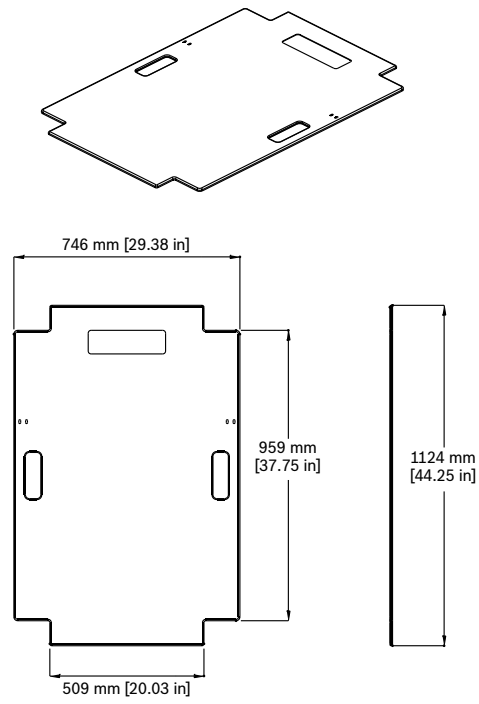


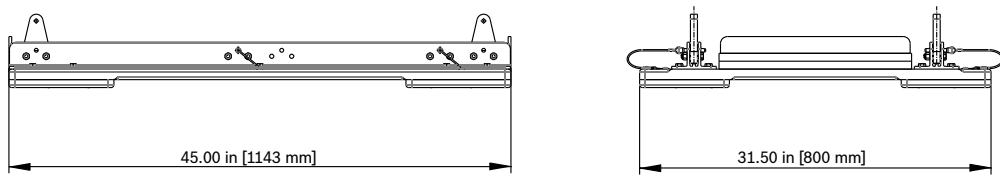
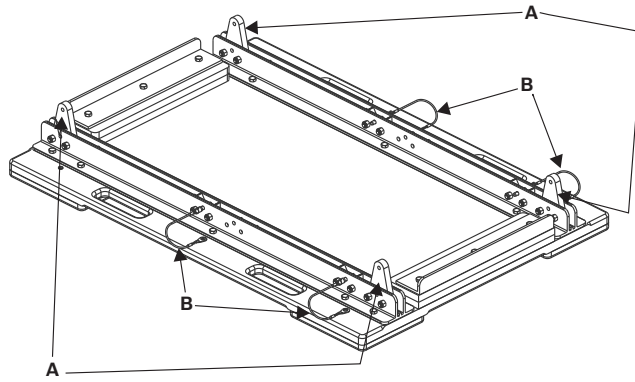
Figure 12.12: Dimensions: X12T-DOLLY top



**Figure 12.13:** Dimensions: X12T-DOLLY transport base

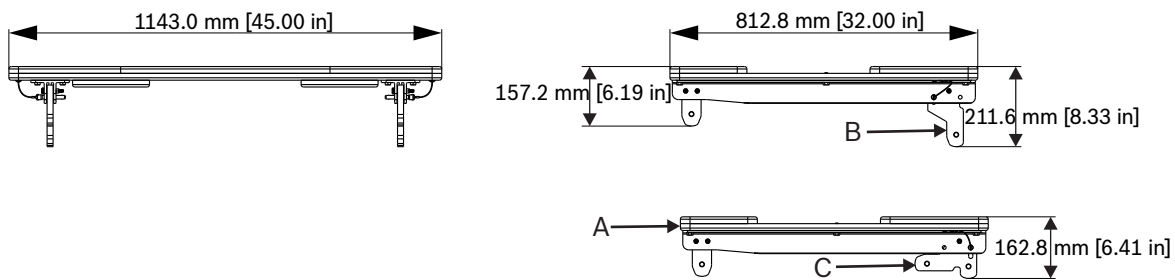
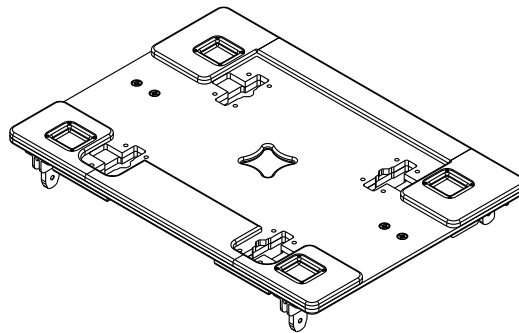


**Figure 12.14:** Dimensions: X12T-DOLLY side panel



**Figure 12.15:** Dimensions: X1/X2 groundstack

Letter	Description
A	Locking bar (2 per side)
B	Detent pins (2 per side)



**Figure 12.16:** Dimensions: X12-125F-DOLLY dolly top

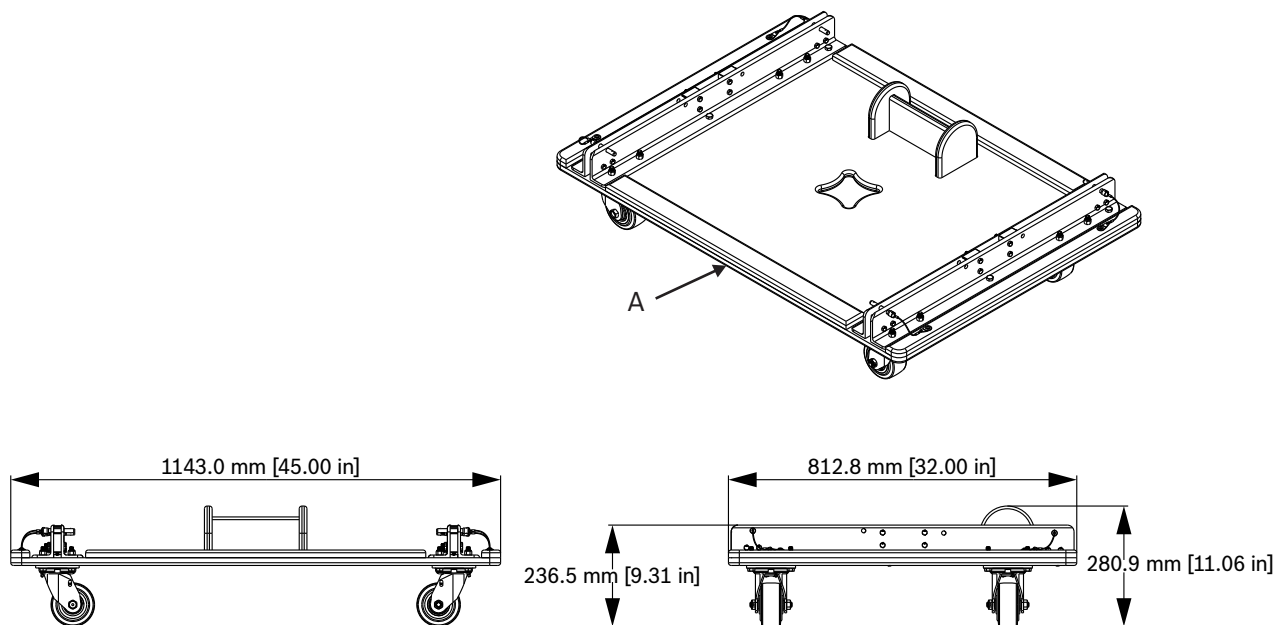


Figure 12.17: Dimensions: X12-125F-DOLLY dolly transport base

Letter	Description
A	Front
B	Rear link bar in transport position
C	Rear link bar in storage position

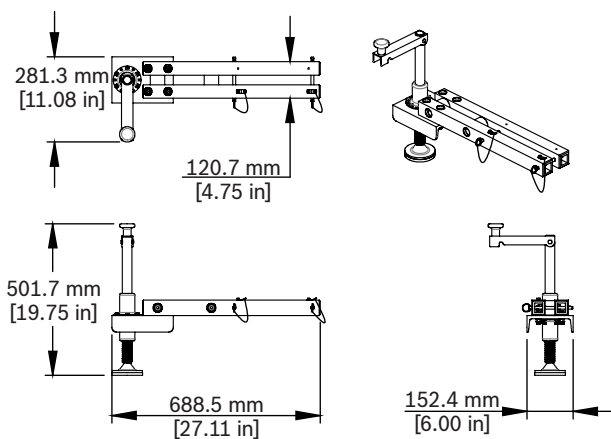


Figure 12.18: Dimensions: X12-125F-DOK dolly adapter kit

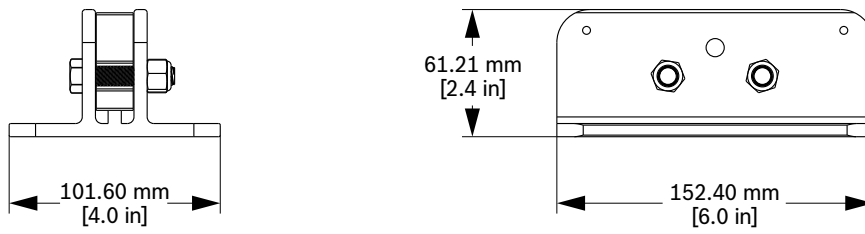
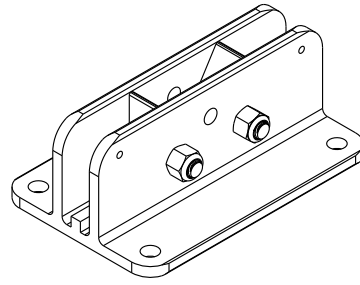


Figure 12.19: Dimensions: X12-125F-DAK dolly adapter kit

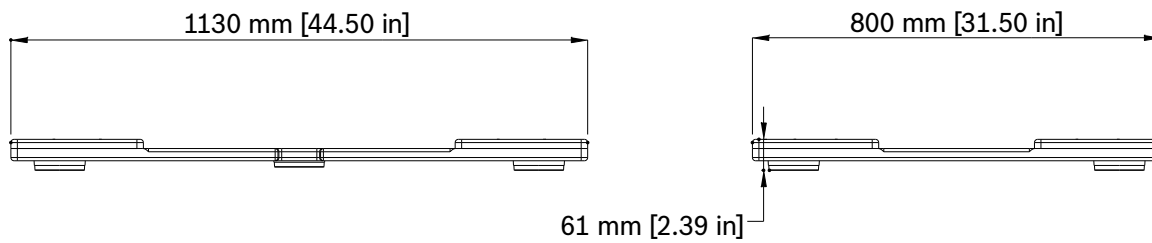
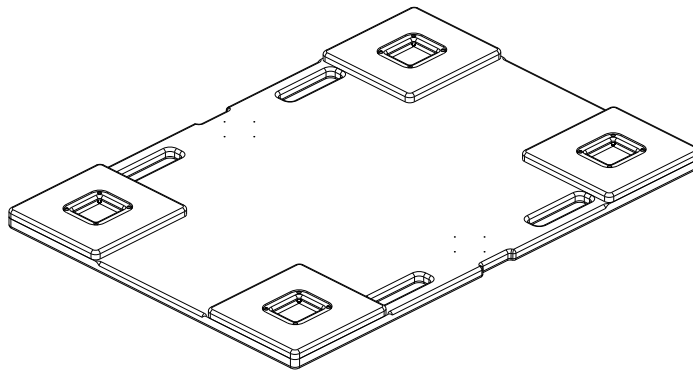


Figure 12.20: Dimensions: X12-128-DOLLY dolly top



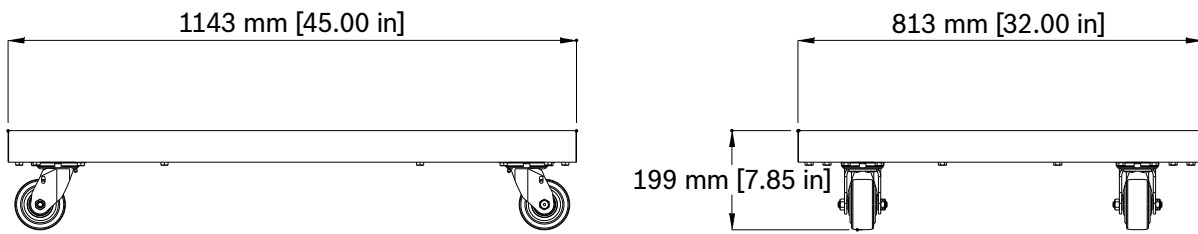
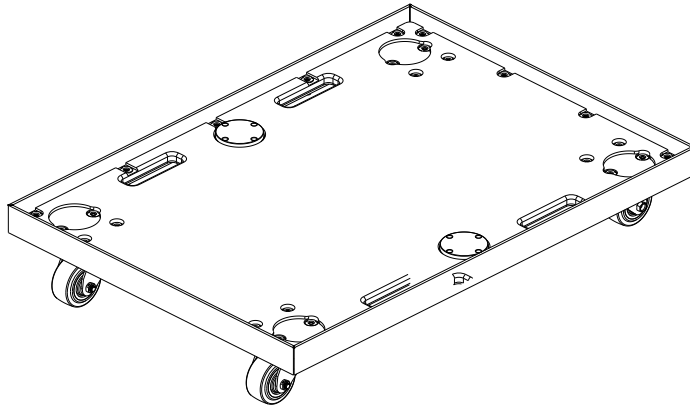


Figure 12.21: Dimensions: X12-128-DOLLY transport base

## 13

## References

### 13.1

### Rigging (printed)

- [1] W.E. Rossnagel, L.R. Higgins & J.A. MacDonald, Handbook of Rigging for Construction and Industrial Operations, McGraw-Hill Book Company, New York, NY, USA (2009).
- [2] H. Donovan, Entertainment Rigging, <http://www.riggingbooksandprograms.com>, Rigging Seminars, Seattle, WA, USA (2002).
- [3] J.O. Glerum, Stage Rigging Handbook, Southern Illinois University Press, Carbondale, IL, USA (2007).
- [4] P. Carter, Backstage Handbook, Broadway Press, New York, NY, USA (1994).
- [5] J. A. Klinke, Rigging Handbook, ACRA Enterprises, Inc., Stevensville, MI, USA (2012).
- [6] Wire Rope Technical Board, Wire Rope Users Manual, American Iron and Steel Institute, Stevensville, MD, USA (2005).
- [7] D. L. Hall, Rigging Math Made Simple, Spring Knoll Press, Johnson City, TN (2014).
- [8] Newberry, W.G., Handbook for Riggers, Newberry Investments Company, Calgary, Alberta, Canada (1989).

-----  
1. \*All other trademarks are property of their respective owners.

### 13.2

### Mechanical engineering (printed)

- [1] R.C. Hibbeler, Engineering Mechanics Statics & Dynamics, Pearson Prentice Hall, Upper Saddle River, NJ, USA (2012).
- [2] R.C. Hibbeler, Mechanics of Materials, Pearson Prentice Hall, Upper Saddle River, NJ, USA (2012).
- [3] J.L. Meriam & L.G. Kraige, Engineering Mechanics, Volume One - Statics, John Wiley & Sons, Inc., New York, NY, USA (2011).
- [4] J.L. Meriam & L.G. Kraige, Engineering Mechanics, Volume Two - Dynamics, John Wiley & Sons, Inc., New York, NY, USA (2012).
- [5] J.E. Shigley & C.R. Mischke, Mechanical Engineering Design, McGraw-Hill Book Company, New York, NY, USA (2014).

### 13.3

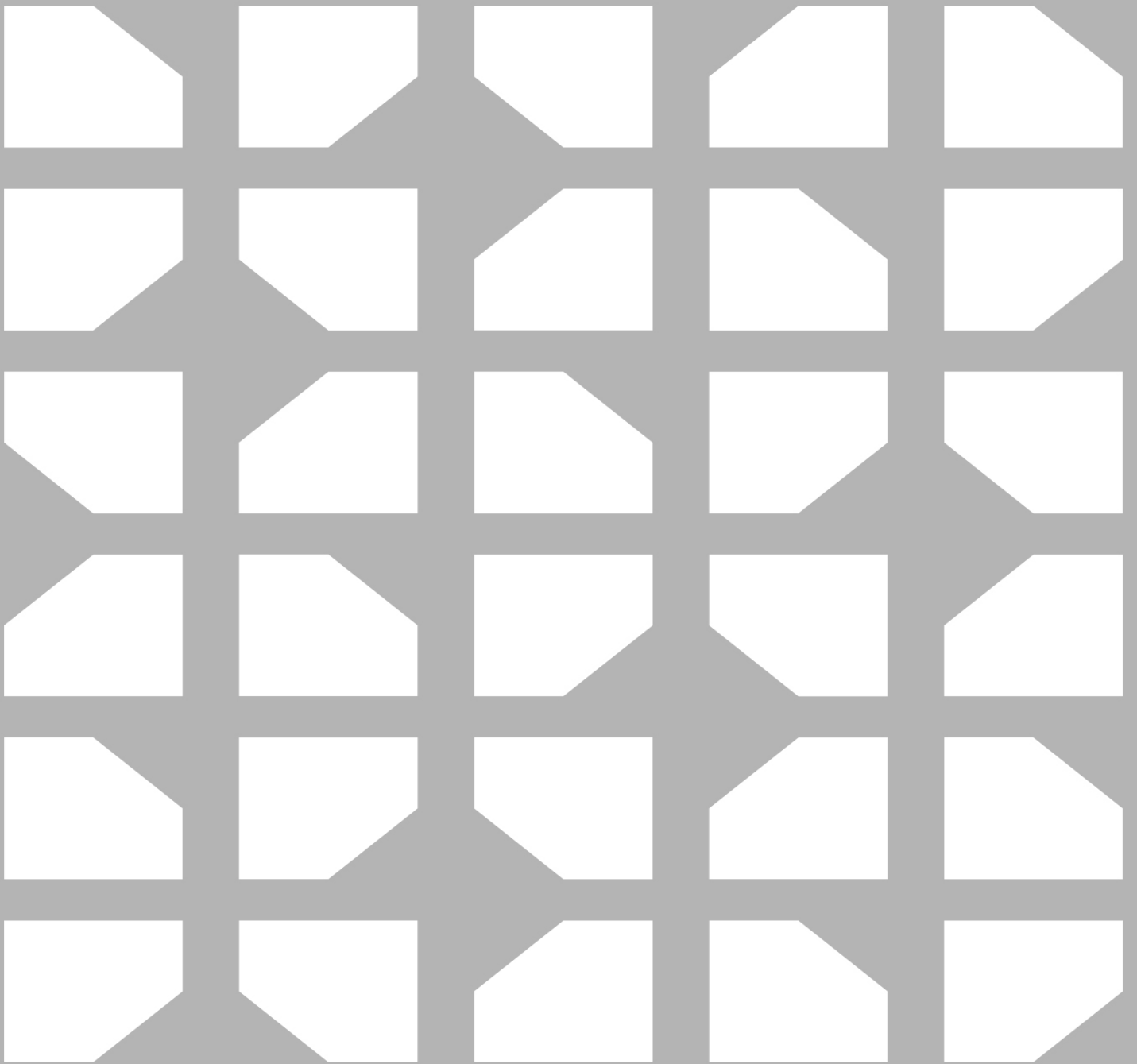
### Rigging (websites)

- [1] <http://www.rigging.net>
- [2] <http://www.cmworks.com/>









**TELEX**

12000 Portland Avenue South

Burnsville MN 55337

USA

**[www.telex.com](http://www.telex.com)**

© Bosch Security Systems, LLC, 2021